

APRIL 1955

RADIO - ELECTRONICS

TELEVISION • SERVICING • HIGH FIDELITY

HUGO GERNSBACK, Editor

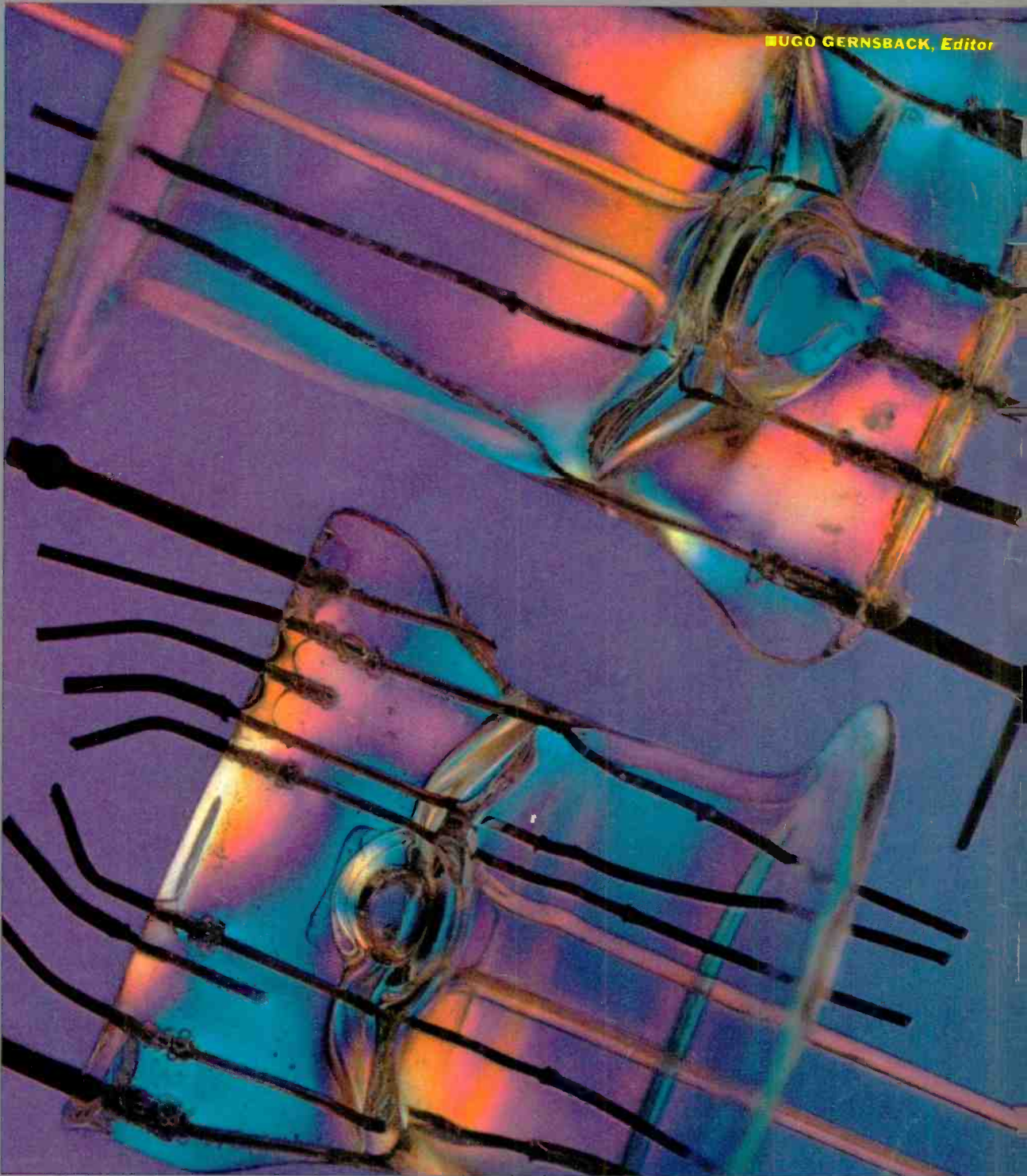

In this issue:

Horn Antenna
For Fringe Areas

Ideas in Horn
Speaker Systems

Sideband Modulator
for
Marker Generator

Intercarrier Buzz

TV Picture Smear

35¢

U. S. and
CANADA

Detecting Strain in Vacuum Tube Envelopes

(See page 4)

New

HICKOK

770

**WIDE BAND...
HIGH SENSITIVITY...
STABLE...**

OSCILLOSCOPE

Especially Designed for
COLOR or BLACK & WHITE
Television

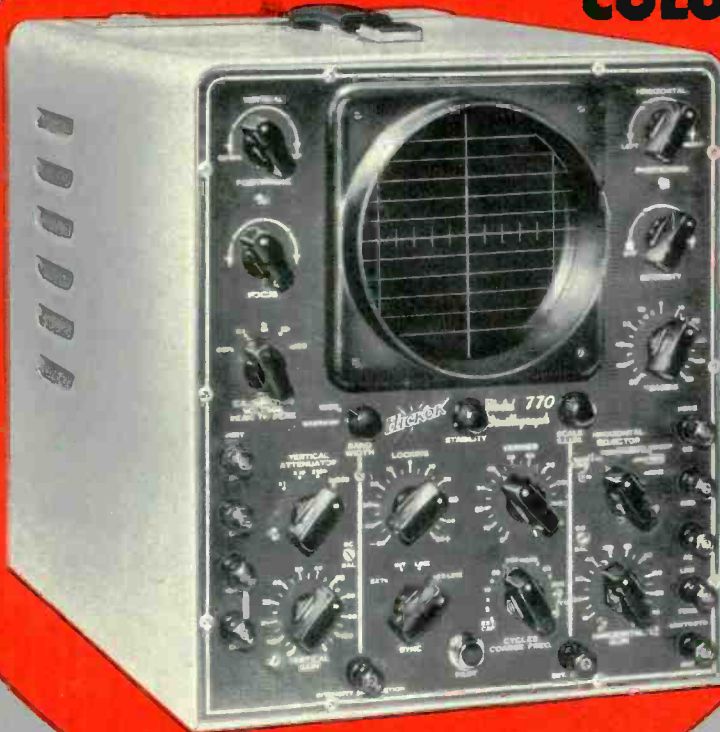

**MODEL
770**

Test leads are included.

- **Wide Band . . .**
DC to 5 megacycles to accurately show colorburst.
- **High Sensitivity . . .**
10 millivolts per inch RMS.
- **Illuminated Calibrated Screen.**
- **Available with long persistence or high actinic CR tube.**
- **Built-in voltage calibrator.**
- **Ideal for many industrial electronic laboratory uses.**
(Similar to a 'Scope recently developed for the Armed Services).

Frequency Range:

- a. **Vertical Amplifier:**
 1. DC to 5 MC, 3db Down, with Band Width Switch in Wide position.
 2. DC to 2.5 MC, 3db Down, with Band Width Switch in Narrow position. (Better than standard IRE standard roll-off characteristics.)
- b. **Horizontal Amplifier:** DC to 500 KC, 3db Down.
- c. **Sweep Circuit Oscillator:** 2 cycles to 30 KC.
- d. **Fixed Sweep Frequencies:** 30 cycles (vertical framing), and 7875 cycles (horizontal framing).

Input Impedance:

- a. **Vertical Amplifier:** 2.2 Megohms—50 MMF.
- b. **Horizontal Amplifier:** 2.2 Megohms—50 MMF.

Deflection Sensitivity:

- a. **Vertical Amplifier:**
 1. .010 RMS Volts/Inch with Band Width Switch in Narrow position.
 2. .035 RMS Volts/Inch with Band Width Switch in Wide position.
- b. **Horizontal Amplifier:** .075 RMS Volts/Inch.

Special Features:

- a. **Illuminated, Calibrated Screen** backed with a green filter for reducing incidental illumination in the room—for accurate measurements and comparisons.
- b. **Built-in calibrated Voltages:** Peak-to-Peak—100, 10, 1, .1 Volts.
- c. **Ideal for Observation of Color Burst** at 3.58 MC.
- d. **Attractive laboratory gray portable steel case.** 12" W, 14" H, 18" D. 50 lbs. net. 105-125 volts. 50-70 cycles. 150 watts.

For those of you who want the very best . . . see and try the 770 at your Parts Jobber today. Write for additional technical details.

THE HICKOK ELECTRICAL INSTRUMENT COMPANY
10531 Dupont Avenue • Cleveland 8, Ohio



I Will Send You BOTH FREE

J. E. SMITH, President
National Radio Institute
Washington 9, D. C.



See How I Train You at Home in Spare Time for Good Pay Jobs in RADIO-TELEVISION

You Practice Broadcasting with Equipment I Send



As part of my Communications Course I send you kits of parts to build the low-power Broadcasting Transmitter shown at left. You use it to get practical experience putting this station "on the air," to perform procedures required of broadcasting station operators. An FCC Commercial Operator's license can be your ticket to a better job and a bright future. My course gives you the training you need to get your license. Mail coupon below. See in my book other valuable equipment you build and keep.

You Practice Servicing with Equipment I Send



Nothing takes the place of PRACTICAL EXPERIENCE. That's why NRI training is based on LEARNING BY DOING. You use kits of parts I furnish to build many circuits common to both Radio and Television. With my Servicing Course you build the modern receiver shown at right. You also build an Electronic Multitester which you can use to help fix sets while training at home. Many students make \$10, \$15 a week extra fixing neighbors' sets in spare time, starting soon after enrolling. I send you special booklets that show you how to fix sets. Mail coupon for 64-page book and actual Servicing Lesson, both FREE.

TRAINING plus OPPORTUNITY is the PERFECT combination. The sample lesson I send will prove to you that it is practical to keep your job while TRAINING right in your own home for better pay and a brighter future. My 64-page book should convince you that Radio-Television is truly today's field of OPPORTUNITY.

TELEVISION MAKING JOBS, PROSPERITY

Radio, even without Television, is bigger than ever. 115 million home and auto Radios create steady demand for service. 3000 Radio stations give interesting, good pay jobs to operators, technicians. NOW ADD TELEVISION. 25 million Television homes and the total growing rapidly. 200 Television stations on the air and hundreds more under construction. Color Television soon to be a reality. Government, Aviation, Police, Ship, Micro-wave Relay, Two-way Communications for buses, taxis, trucks, railroads are growing fields providing good jobs for men who know Radio-Television. All this adds up to good pay now, a bright future later for men who qualify.

START SOON TO MAKE \$10, \$15 A WEEK EXTRA

An important benefit of Radio-Television training is that you can start to cash in fast. Many men I train fix neighbors' sets, make extra money, starting soon after they enroll. Multitester built with parts I send helps locate and correct set troubles. Read at left how you build actual equipment that gives you practical experience, brings to life what you learn from my lessons.

MEN OF ACTION NEEDED MAIL COUPON TODAY

Act now to enjoy more good things of life. Get the benefit of my 40 years' experience training men at home. Take NRI training for as little as \$5 a month. Many NRI graduates (some with only a grammar school education) make more in two weeks than the total cost of training. Find out about this tested way to better pay. Mail coupon below today for Actual Lesson and 64-page Book—BOTH FREE. J. E. SMITH, President, National Radio Institute, Dept. 5DF, Washington 9, D. C. OUR 40TH YEAR.

I TRAINED THESE MEN AT HOME

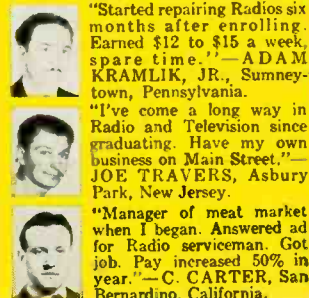

"Started repairing Radios six months after enrolling. Earned \$12 to \$15 a week, spare time."—ADAM KRAMLIK, JR., Sunnyside, Pennsylvania.

"I've come a long way in Radio and Television since graduating. Have my own business on Main Street."—JOE TRAVERS, Asbury Park, New Jersey.

"Manager of meat market when I began. Answered ad for Radio serviceman. Got job. Pay increased 50% in year."—C. CARTER, San Bernardino, California.



"Am with WCOC. NRI course can't be beat. Passed exam for first class Radio-telephone license with no trouble at all."—JESSE W. PARKER, Meridian, Miss.

"Am with WNET as video control engineer on RCA color project. Owe a lot of my success to your textbooks."—WARREN DEEM, Malverne, N. Y.

AVAILABLE TO VETERANS UNDER GI BILLS

Good for Both—FREE

Mr. J. E. SMITH, President, Dept. 5DF, National Radio Institute, Washington 9, D. C.

Mail me Sample Lesson and 64-page Book, FREE. (No salesman will call. Please write plainly.)

Name Age

Address

City Zone State

VETS write in date of discharge

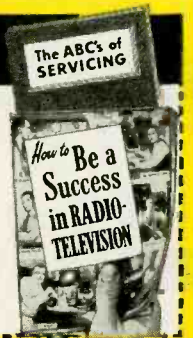

RADIO - ELECTRONICS

Formerly RADIO CRAFT • Incorporating SHORT WAVE CRAFT • TELEVISION NEWS • RADIO & TELEVISION*

Hugo Gernsback
Editor and Publisher
M. Harvey Gernsback
Editorial Director
Fred Shunaman
Managing Editor
Robert F. Scott
W2PWG, Technical Editor
Jerome Kass
Associate Editor
I. Queen
Editorial Associate
Matthew Mandl
Television Consultant
Angie Pascale
Editorial Production
Wm. Lyon McLaughlin
Tech. Illustration Director
Sol Ehrlich
Art Director

Lee Robinson
General Manager
John J. Lamson
Sales Manager
G. Aliquo
Circulation Manager
Adam J. Smith
Director, Newsstand Sales
Robert Fallath
Promotion Manager
Seymour Schwartz
Advertising Production

GERNSBACK PUBLICATIONS, INC.

Executive, Editorial and Advertising Offices, 25 West Broadway, New York 7, N. Y. Telephone REctor 2-8630.

Hugo Gernsback
Chairman of the Board
M. Harvey Gernsback
President
G. Aliquo
Secretary

ON THE COVER

(Story on page 53) Strain patterns in the stem presses of miniature vacuum tubes, as revealed by the polariscope.

Color original by Larry Ankersen, Sylvania Electric Products

APRIL 1955

Vol. XXVI, No. 4

Editorial (Page 29)

Atomelectronics in 1980.....by Hugo Gernsback 29

Audio—High Fidelity (Pages 30-44)

Horn-Type Speaker Systems, Part I—Fundamentals of horn speakers; the folded horn; introduction to the corner horn.....by George L. Augspurger 30

Improving Low-Priced Tape Recorders Part I—A preliminary survey; signal-noise ratio; cutting down hum.....by Herman Burstein 33

Silent Sound.....by Mohammed Ulysses Fips, I.R.E. 36

For Golden Ears Only: The Hartley 215 speaker and the Boffle: Altec 303C Tuner; new records review.....by Monitor 39

Junior Record Player—Amplifier.....by Norman L. Chalfin 42

High-Fidelity Dictionary, Part III.....by Ed Bukstein 43

Adding Versatility to Master Intercom Units.....by John T. Frye 44

Test Instruments (Pages 45-52)

Sideband Modulator for Marker Generator.....by Bruce A. Morrissette 45

A Laboratory Type Tube Tester.....by John A. Dewar 47

Capacitor Testing with Your Ohmmeter.....by Sol D. Prenskey 50

Electronics (Pages 53-59)

Strain in Vacuum Tubes (Cover Feature).....by Vincent C. DeMaria 53

Scanning with Ultrasound.....by S. M. Milanowski 54

New Techniques in Electroencephalography.....by F. J. G. van den Bosch 56

AIEE Goes Electronic.....by Fred Shunaman 58

Aesthetic Oscillography..... 59

Television (Pages 60-94)

Intercarrier Buzz.....by Robert G. Middleton 60

Horn Antenna Construction.....by M. G. O'Leary 62

TV Service Clinic.....Conducted by Jerry Kass 64

TV DX—April—June..... 72

Television—It's a Cinch: (Fifteenth conversation, third part; Differentiation and integration in action, effect of the time constant).....by E. Aisberg 78

An Individual TV Set Trouble Record.....by Henry A. Ahnemann 80

Testing Ion Trap Magnets by James A. McRoberts and Elliott A. McCreedy 84

TV Picture Smear.....by Cyrus Glickstein 90

Radio (Pages 96-100)

Transistor Radio Uses No Power Supply.....by William H. Grace, Jr. 96

Emergency Receiver.....by T. W. Dresser 98

DEPARTMENTS

Books.....	139	People.....	134
Business.....	130	Question Box.....	121
Corrections.....	120	The Radio Month.....	6
Correspondence.....	12	Radio-Electronic Circuits.....	116
New Devices.....	101	Technical Literature.....	137
New Tubes and Transistors.....	104	Technicians' News.....	108
Patents.....	124	Technotes.....	114

Try This One..... 128

Average Paid Circulation over 180,000



RADIO-ELECTRONICS, April, 1955. Vol. XXVI, No. 4. Published monthly at Mt. Morris, Illinois. By Gernsback Publications, Inc. Second Class mail privileges authorized at Mt. Morris, Ill. Copyright 1955 by Gernsback Publications, Inc. Text and Illustrations must not be reproduced without permission of copyright owners.

SUBSCRIPTIONS: Address correspondence to Radio-Electronics, Subscription Dept., 404 N. Wesley Ave., Mt. Morris, Ill., or 25 West Broadway, New York 7, N. Y. When ordering a change please furnish an address stencil impression from a recent wrapper. Allow one month for change of address.

SUBSCRIPTION RATES: U. S., U. S. possessions and Canada, \$3.50 for one year; \$6.00 for two years; \$8.00 for three years; single copies 35c. All other countries \$4.50 a year; \$8.00 for two years; \$11.00 for three years.

BRANCH ADVERTISING OFFICES: Chicago: 7522 North Sheridan Road, Tel. Rogers Park 4-8000. Los Angeles: Ralph W. Harker and Associates, 600 South New Hampshire, Tel. DUinkirk 7-2328. San Francisco: Ralph W. Harker and Associates, 582 Market St., Tel. GARfield 1-2481. **FOREIGN AGENTS:** Great Britain: Atlas Publishing and Distributing Co., Ltd., London E.C. 4. Australia: McGill's Agency, Melbourne. France: Brentano's, Paris 2e. Belgium: Agence et Messageries de la Presse, Brussels. Holland: Trilectron, Heemstede. Greece: International Book & News Agency, Athens. So. Africa: Central News Agency Ltd., Johannesburg. Capetown, Natal. Universal Book Agency, Johannesburg. Middle East: Steimatzky Midale East Agency, Jerusalem. India: Broadway News Centre, Dadar, Bombay #14. Pakistan: Paradise Book Stall, Karachi 3. **POSTMASTER:** If undeliverable send form 3578 to: RADIO-ELECTRONICS, 25 West Broadway, New York 7, N. Y. *Trademark registered U.S. Patent Office.

ADVANCE! Raise your earning power—learn RADIO-TELEVISION-ELECTRONICS by SHOP-METHOD HOME TRAINING

GOOD JOBS AWAIT THE TRAINED RADIO-TV TECHNICIAN

There is a place for *you* in the great Radio-Television-Electronics industry when you are trained as National Schools will train you at home!

Trained technicians are in growing demand at good pay—in manufacturing, broadcasting, television, communications, radar, research laboratories, home Radio-TV service, and other branches of the field. National Schools Master Shop-Method Home Training, with newly added lessons and equipment, trains you in your spare time, right in your own home, for these fascinating opportunities. OUR METHOD IS PROVED BY THE SUCCESS OF NATIONAL SCHOOLS TRAINED MEN, ALL OVER THE WORLD, SINCE 1905.

EARN WHILE YOU LEARN

Many National students pay for all or part of their training with spare time earnings. We'll show you how you can do the same! Early in your training, you receive "Spare-time Work" Lessons which will enable you to earn extra money servicing neighbors' and friends' Radio and Television receivers, appliances, etc.

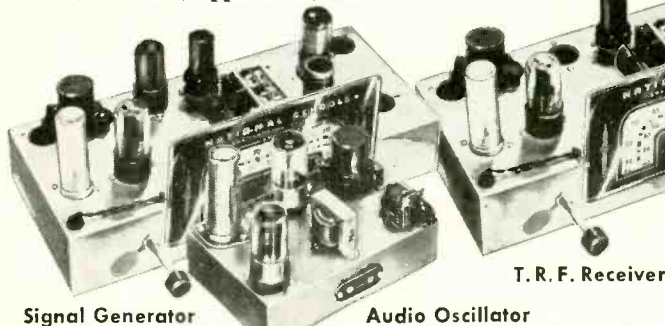

Signal Generator

Audio Oscillator

T. R. F. Receiver

National Schools Training is All-Embracing

National Schools prepares you for your choice of many job opportunities. Thousands of home, portable, and auto radios are being sold daily—more than ever before. Television is sweeping the country, too. Co-axial cables are now bringing Television to more cities, towns, and farms every day! National Schools' *complete* training program qualifies you in all fields. Read this partial list of opportunities for trained technicians:

- Business of Your Own • Broadcasting
- Radio Manufacturing, Sales, Service • Telecasting
- Television Manufacturing, Sales, Service
- Laboratories: Installation, Maintenance of Electronic Equipment
- Electrolysis, Call Systems
- Garages: Auto Radio Sales, Service
- Sound Systems and Telephone Companies, Engineering Firms
- Theatre Sound Systems, Police Radio
- And scores of other good jobs in many related fields.

TELEVISION TRAINING

You get a complete series of up-to-the-minute lessons covering all phases of repairing, servicing and construction. The same lesson texts used by resident students in our modern and complete Television broadcast studios, laboratories and classrooms!



MASTER ALL PHASES!

Get Master Shop-Method Home Training from an Established Practical Resident School with its own Training with almost 50 Years of Successful Experience in Training Ambitious Men.



Shops, Laboratories, Studios — almost 50 Years of Successful Experience in Training Ambitious Men.
We Bring National Schools To You!



You also receive this Multitester

Superheterodyne Receiver

LEARN BY DOING

You receive and keep all the modern equipment shown above, including tubes and valuable, professional quality Multitester. *No extra charges.*

FREE! RADIO-TV BOOK AND SAMPLE LESSON!

Send today for National Schools' new, illustrated Book of Opportunity in Radio-Television-Electronics, and an actual Sample Lesson. No cost—no obligation. Use the coupon now—we'll answer by return airmail.

APPROVED FOR VETERANS AND NON-VETERANS
Check coupon below

Both Resident and Home Study Courses Offered!



NATIONAL SCHOOLS

TECHNICAL TRADE TRAINING SINCE 1905
Los Angeles 37, California • Chicago: 323 W. Polk Street. In Canada: 811 West Hastings Street, Vancouver, B. C.

GET FACTS FASTEST! MAIL TO OFFICE NEAREST YOU!

(mail in envelope or paste on postal card)
NATIONAL SCHOOLS, Dept. RG-45
4000 S. Figueroa Street or 323 West Polk Street
Los Angeles 37, Calif. or Chicago 7, Ill.

Send FREE Radio-TV Electronics book and FREE sample lesson. No obligation, no salesman will call.

NAME _____ BIRTHDAY _____ 19 _____

ADDRESS _____

CITY _____ ZONE _____ STATE _____

Check here if interested ONLY in Resident Training at Los Angeles. VETERANS: Give Date of Discharge

SLIM MODERN

low cost
**CRYSTAL
MICROPHONE**



the NEW
"926"

Another value-leader in the complete line that gives you better choice than ever in crystal microphones! Combines E-V quality features with handsome new slim design—for attractive and effective use in public address, home tape recording and communications. Frequency response is smooth, peak-free 70-8000 cps. High output level. Omnidirectional polar pattern. Can be used in upright or angle position. Hi-Z. Moisture-sealed crystal. Pressure cast case, finished in rich Satin Chromium. $\frac{5}{8}$ "-.27 thread stand coupler. Size $1\frac{3}{16}$ " x $6\frac{3}{4}$ " including swivel mount. 18 ft. cable. Net wt. 11 oz.

Model 926. List Price \$24.50

Ask your E-V Distributor or
write for Condensed Catalog 119

NO FINER CHOICE THAN

Electro-Voice®

ELECTRO-VOICE, INC. • BUCHANAN, MICH.

Export: 13 E. 40th, N.Y. 16, U.S.A.

the
Radio
month



NEW AM RADIO TRANSMITTER, known as the Ampliphase and developed by RCA, represents a significant advance in AM transmitter design. It requires half the space of comparable broadcast equipment and will reduce operating costs by 50%. The unit will be available to radio broadcasters late this year.

Producing 50 kw, the maximum power type transmitter uses phase-modulation principles to produce standard broadcast amplitude modulation. Its circuitry permits two phase-modulated amplifiers to produce a combined power equal to the output of much larger AM transmitters.

To produce 50 kw of modulated signal, a conventional AM transmitter must be able to generate about 35 kw of audio power. The Ampliphase transmitter makes it possible to produce the same signal with only a few watts of audio power.

The Ampliphase circuit has been used successfully in foreign equipment and is particularly advantageous for high-power transmitters operating at 50 kw and above.

TRANSISTOR MANUFACTURE by automatic means is foreshadowed by an experimental machine that carries out a series of 15 steps in making transistors. The equipment was demonstrated recently at the Bell Telephone Laboratories by R. L. Wallace and R. P. Riesz, who originated and developed the equipment.

In an n-p-n transistor there is a narrow layer of positive type germanium sandwiched between two pieces of negative type. The whole forms a fine wire, and the only way to find the

positive layer is to explore the wire slowly with an even finer one while watching a meter for an indication that the nature of the material has changed.

Transistors for research must be highly precise, Dr. Wallace pointed out. The careful process of searching for the positive layer, to which the base connection must be attached, is extremely fatiguing, and tired workers turn out a large percentage of transistors that must be rejected.

The automatic device causes a fine gold wire (to be used as the base connection) to travel along the length of the junction transistor in steps of $1/20,000$ inch. The machine discovers the positive layer and measures its width. Then—on a return trip—it welds the wire to the exact center of the p layer. The other end of the gold wire is then connected to the external base lead of the transistor.

If the transistor is to be of the tetrode type (the machine was designed especially for such transistors), the unit is flipped over and another base terminal is attached to the other side of the p layer. The transistor tetrode thus produced is then given three electrical checks which indicate its most important characteristics. The whole process can be performed in less than a minute.

LIFE EXPECTANCY of radio and television receivers made with printed circuits was estimated at from 8 to 10 years by D. E. Yost of G-E at a symposium on printed circuits at the University of Pennsylvania. He said the survey also disclosed that silver migration, at one time considered a

(Continued on page 10)

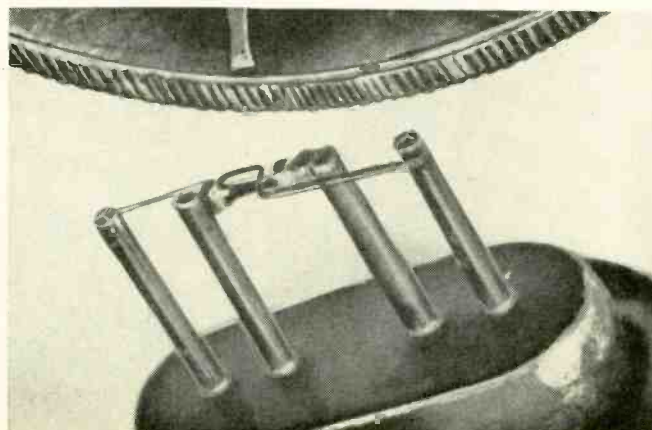

Completed transistor shown next to dime.

All Electronic Parts
YOURS TO KEEP!

Now!
Work over
300
practical projects
WITH THESE
PARTS...



MULTIMETER



5 INCH
"SCOPE"

....TO
HELP YOU LEARN

TELEVISION

RADIO-ELECTRONICS Now ... at home in spare time you can get BOTH the very training and subsequent Employment Service you need to help you start earning real money in America's thrilling, multi-billion dollar opportunity field of Television-Radio-Electronics. Now that Television is coming to almost every community, here is a chance of a lifetime to prepare to cash in on one of Television's great expansions.

D.T.I.'s amazingly practical home method enables you to set up your own HOME LABORATORY. You get many Electronic parts which you mount on individual bases with spring clip connectors. Tops for experimenting! Add or remove parts in a jiffy. No wasted hours of soldering and unsoldering for each project. You spend *minimum* time to get *maximum* knowledge of important circuits that really work. In fact, you get exactly the same type of basic training equipment used in our Chicago training laboratory—one of the nation's finest.

Build and KEEP This VALUABLE TEST EQUIPMENT

Your home laboratory projects also include building and keeping a versatile 5 inch Oscilloscope and precision Jewel Bearing Multi-Meter. These quality commercial test instruments help you **EARN WHILE YOU LEARN** and will prove mighty valuable, should you later decide to start your own full time TV-Radio service business. You also build and keep a quality 21 inch TV SET.

D.T.I. Provides EVERYTHING YOU NEED to master TELEVISION

In addition to your home laboratory and easy-to-read lessons, you even use HOME MOVIES—a wonderfully effective and exclusive D.T.I. training advantage. You watch hidden actions ... see electrons on the march. Important fundamentals ... become "movie clear," helping you learn faster ... easier ... better.

Full time Residential training in D.T.I.'s great Chicago laboratories also available. MAIL COUPON TODAY for all facts. (If subject to Military Service, you'll especially welcome the information we have for you.)

D.T.I.'s Training is available in Canada

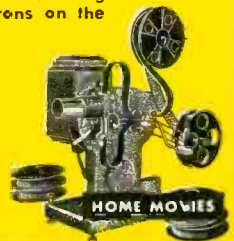

89 WAYS TO EARN MONEY

MAIL COUPON TODAY!



"ONE OF AMERICA'S FOREMOST TELEVISION TRAINING CENTERS"

DEVRY TECHNICAL INSTITUTE

AFFILIATED WITH
DEFORREST'S TRAINING, INC.
CHICAGO 41, ILLINOIS

DEVRY TECHNICAL INSTITUTE

4141 BELMONT AVE., CHICAGO 41, ILL. DEPT. RE-4-L

I would like your valuable information-packed publication showing how I can get started toward a good job or my own business in Television-Radio-Electronics.

Name _____ Age _____

Street _____ Apt. _____

City _____ Zone _____ State _____

Premium Quality Tubes

FOR TV SERVICE

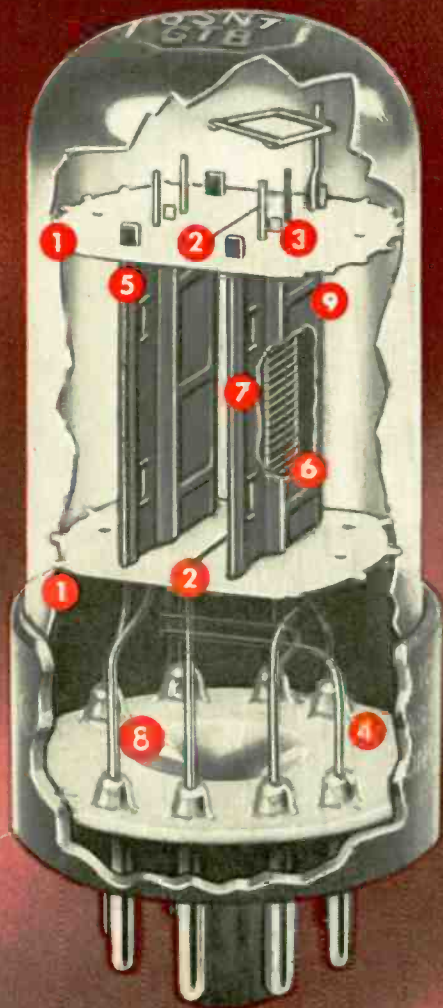

Raytheon Premium Quality Tube Types include:
5U4GB, 5U4GB, 6AX4GB, 6SN7GT-A, 6SN7GTB,
12CU6, 25CU6.

A SPECIAL GROUP OF TUBES THAT GIVE YOU MANY ADVANTAGES AT NO EXTRA COST

*For example Raytheon 6SN7GTB
has these advantages:*

- 1 Bumper point micas top and bottom — mount is held rigid in bulb to reduce vibration and microphonics.
- 2 Slot in micas to reduce leakage between sections.
- 3 Cathode pinched above top mica for tighter mica cathode fit — lower microphonic level.
- 4 Short strong leads support mount at several points.
- 5 All plate tabs pinched or welded above top mica and below bottom mica to strengthen mount.
- 6 Improved grid design for sharper cut off.
- 7 High conductivity grid winding wire to eliminate grid emission.
- 8 Short leads — direct to pins.
- 9 Strict control of plate diameters (Geometry) for uniform characteristics.
- 10 Shorter over all length to improve rigidity.

The lessons learned in structural strength of tubes while developing "rugged" types; the vast warehouse of knowledge about how to make tubes reliable gathered while developing and producing RELIABLE tubes; the revolutionary new thinking and pioneering resulting from the development of the rigid, straight lead Raytheon BANTAL Tubes; the boundless skill, know-how and craftsmanship gathered while designing and producing more than 250 million receiving tubes, millions of special purpose and picture tubes, and millions of semiconductor products; all this experience, gathered through more than 30 years, makes the new Raytheon 6SN7GTB and other tubes in this series — the finest Raytheon Receiving Tubes that we've ever produced.

They're Right . . . for Sound and Sight . . .
Always New . . . and Right for You.



Excellence in Electronics

RAYTHEON MANUFACTURING COMPANY

Receiving and Cathode Ray Tube Operations
Newton, Mass., Chicago, Ill., Atlanta, Ga., Los Angeles, Calif.

RAYTHEON MAKES ALL THESE:

RECEIVING AND PICTURE TUBES • RELIABLE SUBMINIATURE AND MINIATURE TUBES • SEMICONDUCTOR DIODES AND TRANSISTORS • NUCLEONIC TUBES • MICROWAVE TUBES

Let me send you FREE
the entire story

Just fill out the coupon and mail it. I will send you, free of charge, a copy of "How to Pass FCC License Exams," plus a sample FCC-type Lesson, and the amazing new booklet, "Money-Making FCC License Information."



CARL E. SMITH, E.E.
President

I can train you to pass your FCC License Exams in a minimum of time if you've had any practical radio experience — amateur, Army, Navy, radio servicing, or other. My time-proven plan can help put you, too, on the road to success.

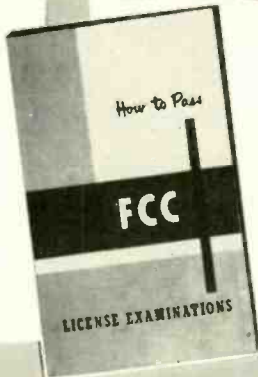

FREE

Tells where to apply and take FCC examinations, location of examining office, scope of knowledge required, approved way to prepare for FCC examinations, positive method of checking your knowledge before taking the examination.

How to Pass FCC COMMERCIAL Radio Operator License Exams

GET YOUR FCC TICKET IN A MINIMUM OF TIME

Get this Amazing Booklet FREE



TELLS HOW

HERE IS YOUR GUARANTEE

If you fail to pass your Commercial License exam after completing our course, we guarantee to continue your training without additional cost of any kind, until you successfully obtain your Commercial license.

WE GUARANTEE

TO TRAIN AND COACH YOU AT HOME IN SPARE TIME UNTIL YOU GET

YOUR FCC LICENSE

If you have had any practical experience—Amateur, Army, Navy, radio repair, or experimenting

TELLS HOW

TV ENGINEERING INCLUDED IN OUR TRAINING & COACHING

Our Amazingly Effective JOB-FINDING SERVICE

Helps GIRE Students Get Better Jobs

Here are a few recent examples of Job-Finding results

BROADCASTING

"Your 'Chief Engineer's Bulletin' is a grand way of obtaining employment for your graduates who have obtained their 1st class license. Since my name has been on the list I have received calls or letters from five stations in the southern states, and am now employed as Transmitting Engineer at WMMT."

Elmer Powell, Box 274, Sparta, Tenn.

CIVIL SERVICE

"I have obtained a position at Wright-Patterson Air Force Base, Dayton, Ohio, as Junior Electronic Equipment Repairman. The Employment Application you prepared for me had a lot to do with my landing this desirable position."

Charles E. Loomis, 4516 Genessee Ave., Dayton 6, Ohio.

AIRLINES

"Due to your Job-Finding Service, I have been getting many offers from all over the country, and have taken a job with Capital Airlines in Chicago, as Radio Mechanic."

Harry Clare, 4537 S. Drexel Blvd., Chicago, Ill.

Your FCC ticket is recognized by employers as proof of your technical ability.

TELLS HOW

Employers make

An Approved Member



JOB OFFERS Like These to Our Graduates Every Month

Letter from nationally-known Airlines:

"Radio Operators and Radio Mechanics are needed for our company. Periodic wage increase with opportunity for advancement. Both positions include many company benefits such as paid vacations, free flight mileage allowance and group insurance."

These are just a few examples of the job offers that come to our office periodically. Some licensed radioman filled each of these jobs . . . it might have been you!

Letter from nationally-known manufacturer:

"We have a very great need at the present time for radio-electronics technicians and would appreciate any helpful suggestions that you may be able to offer."

HERE'S PROOF FCC LICENSES ARE OFTEN SECURED IN A FEW HOURS OF STUDY WITH OUR COACHING AT HOME IN SPARE TIME

Name and Address	License	Time
Harry G. Frame, Box 429, Charleston, W. Va.	2nd Class	13 Weeks
Charles Ellis, Box 449, Charles City, Iowa	1st Class	28 Weeks
Omar Bibbs, 1320 E. 27th St., Kansas City, Mo.	1st Class	34 Weeks
Kenneth Rue, Dresser, Wisconsin	2nd Class	20 Weeks
B. L. Jordan, Seattle, Washington	1st Class	20 Weeks

CLEVELAND INSTITUTE OF RADIO ELECTRONICS

CARL E. SMITH, E. E., Consulting Engineer, President
Desk RE-75 — 4900 Euclid Bldg., Cleveland 3, Ohio



Get All 3 FREE

MAIL COUPON NOW

CLEVELAND INSTITUTE OF RADIO ELECTRONICS

Desk RE-75, 4900 Euclid Bldg., Cleveland 3, Ohio
(Address to Desk No. to avoid delay)

I want to know how I can get my FCC ticket in a minimum of time. Send me your FREE booklet, "How to Pass FCC License Examinations" (does not cover exams for Amateur License), as well as a Sample FCC-type lesson and the amazing new booklet, "Money-Making FCC License Information." Be sure to tell me about your Television Engineering Course.

NAME _____

ADDRESS _____

CITY _____ ZONE _____ STATE _____

FOR PROMPT RESULTS SEND AIR MAIL
Special tuition rates to members of the U. S. Armed Forces

Quality Features OF TUNG-SOL PICTURE TUBES



Gun made of best grade non-magnetic steel.

Glass bead type assembly is stronger both mechanically and electrically—gives greater protection against electrical leakage.

Rolled edges in gun minimize corona.

Custom built stem with greater spacing between leads assures minimum leakage.

Low resistance of outside conductive coating minimizes radiation of horizontal oscillator sweep frequency.

Double cathode tab provides double protection against cathode circuit failure.

Selected screen composition resists burning (X pattern).

Rigid control of internal conductive coating provides utmost service reliability.

Designed for use with single or double field ion trap designs.

One-piece construction of parts assures better alignment.

Maximum dispersion of screen coating assures uniform screen distribution.

Tung-Sol makes All-Glass Sealed Beam Lamps, Miniature Lamps, Signal Flashers, Picture Tubes, Radio, TV and Special Purpose Electron Tubes and Semiconductor Products.

TUNG-SOL ELECTRIC INC., Newark 4, N. J. Sales Offices: Atlanta, Chicago, Columbus, Culver City (Los Angeles), Dallas, Denver, Detroit, Newark, Seattle.

TUNG-SOL® RADIO AND TV TUBES

You Can Build a Reputation On Tung-Sol Quality

THE RADIO MONTH

serious problem with printed circuits, was virtually nonexistent in radio and television receivers.

Silver migration caused deterioration of printed circuits after a time, rendering the instrument useless. Yost said this was particularly true in areas with high humidity. However, the high heat of radio and television receivers dissipates the moisture, even in areas of high humidity.

AMERICA-EUROPE TV LINK by way of a television submarine cable is not far fetched. In a paper describing details of the proposed trans-Atlantic telephone cable between Newfoundland and Scotland, presented at the Winter General Meeting of the American Institute of Electrical Engineers, several internationally known engineers brought up the possibility of America and Europe exchanging television programs in the future.

They stated, "A trans-Atlantic submarine cable is a long-range goal worthy of serious study and by no means to be dismissed as impractical of eventual attainment. The transistor looms as a development which has the potentialities for making possible long, deep-water submarine cables with much greater communication capacity than can be realized with repeaters employing thermionic tubes."

It is expected that 1956 will see the completion of the first trans-Atlantic telephone connection via submarine cable.

TV SERVICE MONTH, a nationwide promotion campaign, is being sponsored by G-E. It will run from April 19 to May 19 and feature a \$25,000 (\$10,000 first prize) cash prize contest. Mr. J. M. Lang, general manager of G-E's Tube Department, in announcing the plan said that the concept of a *TV Service Month* will be publicized through every possible channel to focus attention on the service dealer as a friend and neighbor and to call for direct action in ordering long-put-off repairs.

The program will be kicked off by publication in *Look* magazine of a directory of the thousands of service dealers who handle G-E tubes. A *TV Service Month* emblem that identifies each dealer's shop as a headquarters for the \$25,000 jingle contest is one of the many promotional aids. Another is a talking postcard which customers can play on their phonograph.

LONG-DISTANCE WAVEGUIDE, a new and radically different medium for transmitting television and telephone conversations over long distances, has been used successfully in experiments by Bell Telephone Laboratories. Bell scientists believe the new waveguide may someday simultaneously carry tens of thousands of cross-country telephone conversations along with hundreds of television programs.

The waveguide is made of hollow

(Continued)

tubing (see photo) approximately 2 inches in diameter. The tubing is constructed of a thin copper wire, very tightly coiled—like a spring under pressure—and wrapped inside a flexible outer coating which holds the coiled wire in place. The tube need not be



Bell Labs new long distance waveguide.

straight and can carry signals around corners.

Although this new form of transmission, markedly different from modern cable or radio relay systems, is still in the experimental stage, a recent long-distance test was made in a copper pipe 500 feet long. Engineers bounced signals back and forth in the tube for distances of 40 miles. They calculated that in comparison the same waves could have traveled only 12 miles in a coaxial cable with the same loss in strength.

The new transmission system operates in a frequency range so high that it does not have a name. The super-high-frequency range goes to 30,000 mc—the carrier frequency for the new waveguide is about 50,000 mc.

A major difference between transmission through the new waveguide and through previous systems is that the higher the frequency in the waveguide, the less the loss through attenuation. This is exactly the reverse of other forms of transmission.

FACSIMILE playing important role in revolutionary new type of ticket and reservation center at the Pennsylvania Railroad's Thirtieth Street Station in Philadelphia. When ordering a reservation, the ticket seller selects a pre-printed coupon showing date, time and place of departure, destination, accommodation and car number. He places this coupon in a high-speed facsimile machine which immediately reproduces a Pullman or reserved seat coach ticket.

The new setup also provides for direct facsimile transmission of reserved space tickets into offices of subscribers in the Philadelphia area. An order form is transmitted by facsimile from the subscriber's office to the ticket office, and the ticket ordered is immediately transmitted to a subscriber. END

FREE

1955 ALLIED 308-PAGE CATALOG

the only COMPLETE catalog
for everything in TV, Radio
and Industrial Electronics

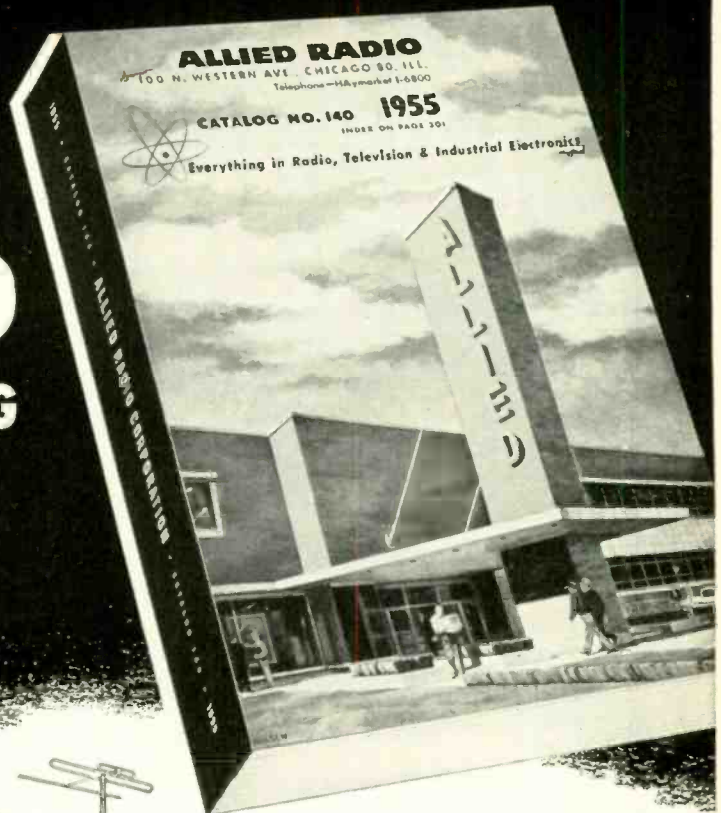

World's largest Stocks

- All TV and Radio Parts
- All Electron Tube Types
- Test and Lab Instruments
- High Fidelity Equipment
- Custom TV Chassis
- AM, FM Receiving Equipment
- Recorders and Supplies
- P.A. Systems, Accessories
- Amateur Station Gear
- Builders' Kits, Supplies
- Equipment for Industry

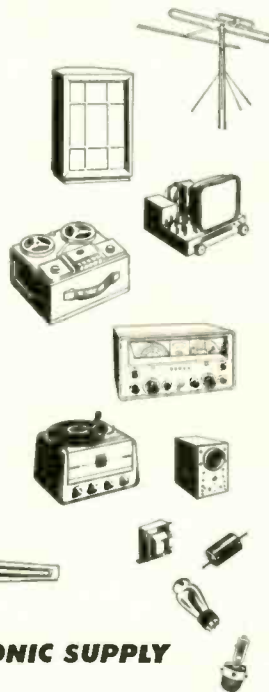

ultra-modern facilities for the
FASTEST SERVICE IN ELECTRONIC SUPPLY

SEND FOR IT TODAY!

Get ALLIED's 1955 Catalog—308 pages packed with the world's largest selection of quality electronic equipment at lowest, money-saving prices. Select from the latest in High Fidelity systems and components; custom TV chassis, TV antennas and accessories; AM and FM receiving equipment; P. A. systems and accessories; recorders and supplies; Amateur receivers, transmitters and station gear; specialized industrial electronic equipment; test instruments; builders' kits; huge listings of parts, tubes, tools, books—the world's *most complete* stocks of quality equipment. ALLIED gives you *every* buying advantage: fastest shipment, expert personal help, lowest prices, assured satisfaction. Get the big 1955 ALLIED Catalog. Keep it handy. Send for your FREE copy today.

**IT'S VALUE PACKED... SAVE ON
EVERYTHING IN ELECTRONICS**

**SEND FOR THE LEADING
ELECTRONIC SUPPLY GUIDE**

FREE



ALLIED RADIO
world's largest Electronic Supply House

EASY-PAY TERMS

Use ALLIED'S liberal Easy Payment Plan—only 10% down, 12 months to pay—no carrying charges if you pay in 60 days. Available on Hi-Fi and P.A. units, recorders, TV chassis, test instruments, Amateur gear, etc.

HI-FI SPECIALISTS

To keep up with the latest and best in High Fidelity, look to ALLIED. Count on us for all the latest releases and largest stocks of Hi-Fi equipment. We specialize, too, in TV supply, and are foremost in the field of Builders' Kits.

ALLIED RADIO CORP., Dept. 2-D-5

100 N. Western Ave., Chicago 80, Illinois

Send FREE 308-Page 1955 ALLIED Catalog.

Name _____

Address _____

City _____ Zone _____ State _____



for HI-FI

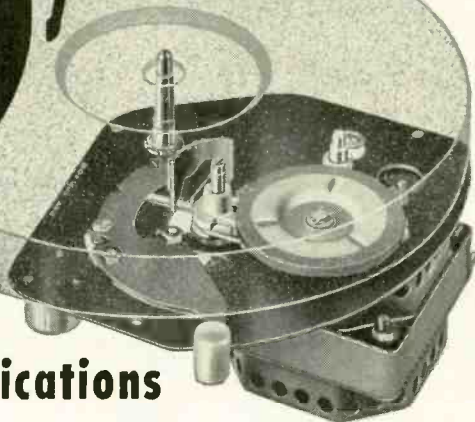

MODEL DSS
3-speed, 4-pole motor

and ALL
phonomotor applications



MODEL D-10
4-pole, shaded pole AC Induction type for tape, wire or disc recorders



MODEL RM4
Single speed, 4-pole motor



MODEL SS—3-speed,
2-pole motor

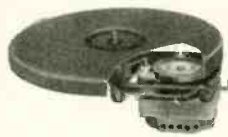

MODEL DR—2-speed,
4-pole motor



MODEL AX
Single speed, 2-pole motor

On any job, large or small—from a single-speed nursery phonograph to a super-deluxe “hi-fi” instrument—you’ll always be right if you follow the lead of America’s foremost manufacturers and *Specify GI* phonomotors. GI is America’s *only complete* line—the *one* source for *every* phonomotor need—with quality and dependability backed by over half a century of design leadership!



THE GENERAL INDUSTRIES CO.

DEPARTMENT GE • ELYRIA, OHIO

OVER 97,000 TECHNICIANS HAVE LEARNED
HOW TO GET THE MOST OUT OF
BASIC TEST EQUIPMENT

for AM
FM-TV

‘Servicing by Signal Substitution’

A BEST SELLER FOR OVER 13 YEARS!
(NEW, UP-TO-DATE, 14th EDITION)

The Modern, Simplified, Dynamic Approach to
all Receiver Adjustment & Alignment Problems

- ★ Nothing complicated to learn
- ★ No extra equipment to purchase
- ★ Universal . . . non-obsolete
- ★ Employs only Basic Test Instruments

Ask for “S.S.S.” at your local Radio
Parts jobber or remit 40¢ in small
stamps or coin directly to factory.

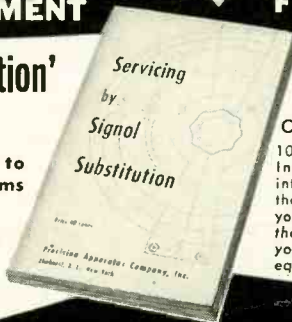

ONLY 40¢

103 pages.
Invaluable
information
that will help
you redouble
the value of
your basic test
equipment.

PRECISION APPARATUS COMPANY, INC.
70-31 84th STREET, GLENDALE 27, L. I., N. Y.

Correspondence

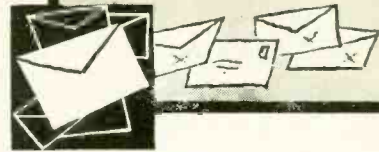

PIANO CORRECTION

Dear Editor:

Unfortunately there is an error in Fig. 1 of the Stringless Electronic Piano article (February, 1955). As shown, the dual pickups are at the tip end of the reed, whereas they actually are located at points which are about 22% of the total reed length from the tip end, where the second partial has a node. This was stated in the text.

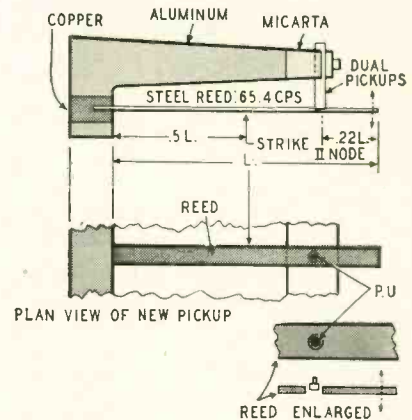

A later model uses only one pickup at this same point, in a hole in the reed. This dual-opposed pushpull action also neutralizes translation of any accidental lateral reed vibration. Additionally and importantly, it increases the output tone dynamic range, from high to low reed vibration amplitudes, by shortening the air gap between the reed and the pickup head at high-amplitude vibrations. This is due to the slight double curvature of the reed while the second partial is initially present, which shortens the distance between its fixed end and the tip end side of the reed hole, where the pickup capacity is concentrated.

B. F. MIESSNER

Morristown, N. J.

I-TUBE CIRCUIT?

Dear Editor:

I wish to exclaim as did Mr. Noble D. Carlson (January) on Color Coded Clips. On page 166 of your January issue you have a novel British one-tube deflection circuit. This circuit contains two tubes—it has a damper.

The circuit was apparently abandoned years ago by U. S. set manufac-

An Invitation . . .

To men who want to "go places" in TV SERVICING

Find out about this **NEW,**
ALL-PRACTICE WAY
of becoming a **Professional**
TV SERVICEMAN

If you have some Radio or Television experience, or if you know basic Radio-Television principles but lack experience—NRI's new Professional Television Servicing course can train you to go places in TV servicing. This advertisement is your personal invitation to get a free copy of our booklet describing this training in detail.

Learn-by-Doing "All the Way"

This is 100% learn-by-doing, practical training. We supply all components, all tubes, including a 17-inch picture tube, and comprehensive manuals covering a thorough program of practice. You learn how experts diagnose TV defects quickly. You see how various defects affect receiver performance—picture and sound; learn causes of defects, accurately, easily, and how to fix them. You do more than just build circuits. You get practice recognizing, isolating, and fixing innumerable troubles.

You get actual experience aligning TV receivers, diagnosing the causes of complaints from scope patterns, eliminating interference, using germanium crystals to rectify the TV picture signal, obtaining maximum brightness and definition by properly adjusting the ion trap and centering magnets, etc. There isn't room on this or even several pages of this magazine to list all the servicing experience you get.

UHF & COLOR TV Making New Boom

Installing front-end channel selector strips in modern UHF-VHF Television receivers and learning UHF servicing problems and their solution is part of the practice you get. To cash in on the coming color TV boom you'll need the kind of foundation in knowledge and experience this training gives.

Get Details of New Course Free

Once again—if you want to go places in TV servicing, we invite you to find out what you get, what you practice, what you learn from NRI's new course in Professional Television Servicing. See pictures of equipment supplied, read what you practice. Judge for yourself whether this training will further your ambition to reach the top in TV servicing. We believe it will. We believe many of tomorrow's top TV servicemen will be graduates of this training. Mailing the coupon involves no obligation.



Train at home easily, quickly, for TV's top servicing jobs. NRI's Professional Television Servicing course includes a 17-inch picture tube and all other tubes and components to build a complete TV Receiver, Oscilloscope, Signal Generator, H.F. Probe. Complete training, including all equipment, available now for a low introductory price—under \$200 on easy terms.



National Radio Institute, Dept. 5DFT
16th and U Sts., N.W., Washington 9, D. C.

Please send my FREE copy of "How to Reach the Top in TV Servicing." I understand no salesman will call.

Name.....Age.....

Address.....

City.....Zone....State.....

WHO'S THE ONE YOU TALK TO



It's a

AND WOMEN BUY

A Crossley, Incorporated survey shows that this Seal influences 53% of *all* women in their purchases of everything from raisins to refrigerators . . .

and . . . *CBS TUBES* have the Good Housekeeping Guaranty Seal! When you

**SO-O-O-O
ADVERTISES**

CBS is the *first and only* tube manufacturer to address its advertising to women.



CBS tubes will be consistently advertised throughout the year in Good Housekeeping and Life, reaching 17,171,419 readers every time an advertisement appears!

CBS-HYTRON Main Office: Danvers, Massachusetts • A DIVISION OF CBS . . . THE COLUMBIA BROADCASTING SYSTEM, INC.

A member of the CBS family: CBS Radio • CBS Television • Columbia Records • CBS Laboratories

ON MOST SERVICE CALLS ?

Woman...

... BY THIS SEAL

install CBS tubes you leave no question in your customer's mind about the quality of the tubes you supply. Keep *your* customers happy — with CBS tubes, the tubes with the *Good Housekeeping Guaranty Seal* on the carton.



**... CBS
TO WOMEN**

And it's women you talk to on most service calls.

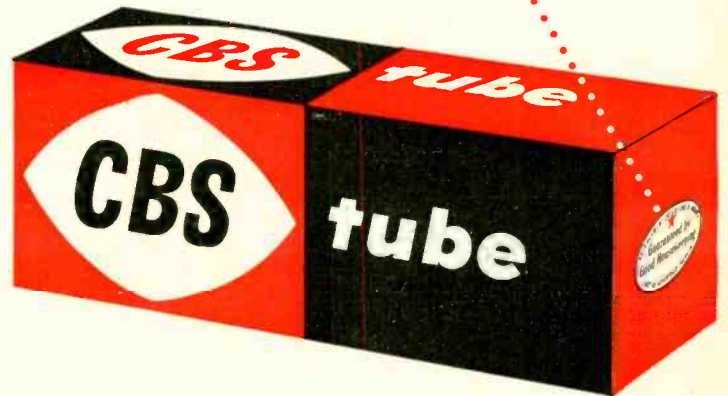

*Quality products through **ADVANCED-ENGINEERING***

**CASH IN WITH THIS NEW
CBS TUBE
SALES PROMOTION KIT!**

Ask your distributor for special offer, or mail coupon *today.*

CBS-Columbia • CBS International • and CBS-Hytron

CBS-HYTRON, Danvers, Mass.
Please rush me the new CBS TUBE SALES PROMOTION KIT, PA-70, containing:

- 1. Three Truck Posters
 - 2. Metal Frame for Truck Posters
 - 3. Window Display with three-dimension Giant CBS Tube Carton
 - 4. New Inside/Outside Decal
- I enclose \$2.00 to cover the cost of this kit.

Name.....
 (please print name and address)
 Street.....
 City.....State.....

PERMOFLUX ANNOUNCES

The NEW

Largo-12

Big brother to the famous "Largo 8"



New, complete two-way speaker system —
with all the time-tested, proven features of the "Largo 8"
plus:

- More powerful Super Royal 12" Speaker
- New, larger, back-loaded horn enclosure
- Full 20-watt power-handling capacity
- Smooth peak-free response . . . 30 to 16,000 cycles

Combined with: • Scientifically matched 32KTR Super Tweeter • Slanted speaker panel for proper sound focusing
• High-frequency balance control • Horn loading of back wave thru unique cabinet base. The Largo 12 is precision-constructed of beautiful $\frac{3}{4}$ " Mahogany or Korina Blonde cabinet woods. Impedance, 8 ohms.
Size: 23 $\frac{1}{8}$ " H, 27 $\frac{1}{2}$ " W, 15 $\frac{1}{2}$ " D.

Audiophile NET.....\$149.50
(Also available in Walnut at slightly higher price.)

H.T.P.

The Largo 12 is available under the exclusive Permoflux insured Home Trial Plan (HTP). Try it in the comfort and quiet of your own home for 15 days—with your own records and associated equipment. For a limited time only, each HTP participant will receive—absolutely FREE—the new Permoflux "Maestro" speaker-Headset Control Box (\$10.00 value). Also available under HTP: the Diminnette (\$49.50); the Largo 8 (\$99.75).

Only Permoflux gives you all the features you should have in a 2-way high-fidelity speaker system. See and hear the Largo 12 and other Permoflux systems at your hi-fi dealer today. Also ask him about HTP—or write:

Permoflux CORPORATION

Dept.D, 4912 West Grand Avenue • Chicago 39, Illinois
West Coast Plant • 4101 San Fernando Road • Glendale 4, California
Canadian Licensee • Campbell Manufacturing Co., Ltd., Toronto, Canada

CORRESPONDENCE (Continued)

turers. Refer to Photofacts folders around 1949 or look up an old Bendix diagram. They really had a one-tuber.

CHARLES SAMUELSON
Youngsville, Pa.

(Combination horizontal oscillator and output stages using one single-purpose tube have been used by several manufacturers in a few models. This practice was not widely adopted and the number of sets using one-tube horizontal deflection circuits is so small that many technicians have never seen or heard of them. The one-tube British horizontal deflection circuit was described not because we felt that it was previously unheard of but because we believe it is rare and unusual.

We still consider the circuit a one-tuber because the 6CD6-G will oscillate with the damper removed from the circuit. If you want to see a one-tube oscillator and output circuit without a damper, take a look at the circuit of the Muntz M-158 or M-159.

The output tube, called the horizontal output and oscillator, is fed directly from the output of the sync separator.
—Editor)

CLARIFYING THE ISSUE

Dear Editor:

Some people seem to feel that I advocate very complex articles that cannot be understood by any but the best trained individuals in the electronics field. Possibly this feeling is the result of reading the Correspondence column, December, 1954.

Prior to October, Mr. Dorf (author of the articles I questioned) accused me of advocating involved articles beyond the comprehension of his readers. His language is much the same as that in the December column.

Please allow me to quote from a letter that I sent Mr. Dorf on October 3, 1954, a date considerably prior to your December issue. "You have missed the point of my letters. I'm not accusing you of overly simplifying discussions or of lacking to give full development to background and math involved. I realize as well as you that the majority of readers of RADIO-ELECTRONICS do not have the technical tools to understand all the math and development that could accompany an article. I'm accusing you of leading the readers to a wrong conception of some of the points you discuss. Any diagrams, equations and statements of principle in my letters are for your benefit, so that you can see your error demonstrated, as I do not feel you would be inclined to believe me if I merely tell you that you are wrong. It is one thing to simplify and another thing to tell an untruth. And it is precisely the readers without the technical understanding and background who should be protected from the possibility of an author starting them down a path of misconception. . . ."

WILLIAM HOLM

East Lansing, Mich.

Get this FREE Booklet Today!

LOADED WITH CAREER-BUILDING FACTS — IT CAN LEAD YOU TO A BIGGER JOB, BETTER PAY, SECURITY AND SUCCESS IN RADIO — TV — ELECTRONICS

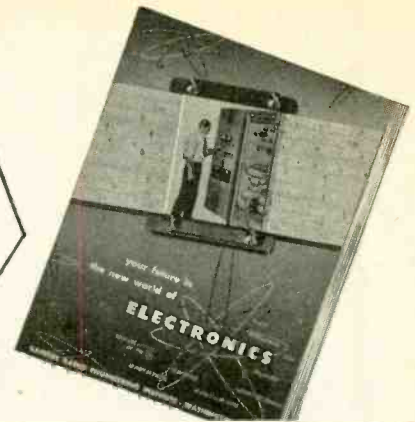

“YOUR FUTURE IN THE NEW WORLD OF ELECTRONICS” — contains a proved plan for your successful career in:

- ★ BROADCASTING
- ★ TELEVISION
- ★ MANUFACTURING
- ★ COMMUNICATIONS
- ★ SERVICING
- ★ AERONAUTICAL ELECTRONICS
- ★ ARMY, NAVY, AIR FORCE, COAST GUARD ELECTRONICS

A PROVED CAREER-PREPARATION PLAN THAT WORKS!

This free book has brought success home to thousands of men just like you! They are now enjoying responsible jobs, good pay and the good things of life. So can you! In less time than you think! We tell you how you can carve out a bigger better-paying job. Our proved career-preparation plan works because it was written by authorities who know exactly what the varied electronic industries want, need and expect from you!

ELECTRONICS' FUTURE CAN BE YOUR FUTURE

You can't keep up with the tremendous changes in the electronic industries. What's predicted for next year becomes outdated in a few months! All phases of the electronic industries are experiencing phenomenal growth. There are thousands of career openings, big ones. Industry can't find enough trained manpower to fill them—in manufacturing, testing, servicing, broadcasting and telecasting.

TAKE TV FOR EXAMPLE!

Four hundred and six stations are on the air! Many more are building or in

the plans stage; 32,859,915 sets are in use. Color TV is just starting to really come alive! This same phenomenal growth picture is repeated in every phase of business employing electronics—crime prevention, aeronautics, fire-fighting, communications, to name but a few. CREI has the plan to keep you moving upward, to help you assume your rightful place!

CREI GRADS ARE IN DEMAND!

The big companies know CREI men have what it takes! CREI grads are at work in America's biggest corporations, in positions ranging from technicians to engineers to top management. Companies such as United Air Lines, Canadian Broadcasting Corporation, Trans-Canada Airlines, Sears-Roe-



“I chose CREI training upon recommendation of two top engineers. Before I had completed the course I became transmitter chief of a 5 KW station. I am now employed as a technician at a 100 KW TV station, and in spare time have a good TV sales and service business. Anyone interested in his electronic future should have CREI training.” —Archie D. Patton, San Antonio, Texas

CREI GRADS EASILY PASS FCC EXAMS!

You start feeling the benefits of CREI training right away, either with your present connection, or with a future employer. You'll have all the training you need to secure your FCC commercial license.

ACT NOW! TAKE THAT FIRST BIG STEP!

Fill out and mail the coupon. When you do, you'll be on the way to higher pay, a better job and complete career security. Act right away. Send for your free book today.

THOUSANDS LIKE YOU HAVE SUCCEEDED WITH CREI'S PLAN! “CREI TRAINING IS BEST”

“I know of no case in which a man who applied himself and completed the CREI course failed to better himself through promotion and increase in salary.” . . . —Wendell L. Fraser, San Diego, Calif.

“—CREI has raised me to professional status as a radioman. Thanks to your instructors who always gave me needed help.” —Victor Mentzer, Wilmington, Del.

“—I have been in radio and electronics for 24 years. I fully recommend CREI as the best school I have seen.” —L. McManus, Montreal, Canada

CAPITOL RADIO ENGINEERING INSTITUTE

Accredited Technical Institute Curricula
Founded in 1927.
3224 — 16th Street, N.W.
Washington 10, D.C.

CREI also offers resident instruction: at the same high technical level, day or night, in Washington, D.C. New classes start frequently during the year. If this type of instruction meets your requirements, check the coupon for Residence School catalog. Qualified residence graduates may earn the degree of Associate in Applied Science.

INFORMATION FOR VETERANS

If you were discharged after June 27, 1950—let the new G.I. Bill of Rights help you obtain resident instruction. Check the coupon for full information.

MAIL THIS COUPON Today!

CAPITOL RADIO ENGINEERING INSTITUTE
Dept. 144-B, 3224 16th St., N. W., Washington 10, D. C.

Please send me your course outline and FREE Illustrated Booklet “Your Future in the New World of Electronics” . . . describing opportunities and CREI home study courses in Practical Electronics Engineering.

- CHECK FIELD OF GREATEST INTEREST
- Practical Radio Engineering
 - Broadcast Radio Engineering (AM, FM, TV)
 - Practical Television Engineering
 - Aeronautical Electronics Engineering
 - TV, FM & Advanced AM Servicing

Name.....

Street.....

City..... Zone..... State.....

CHECK: Residence School Veteran

To help us answer your request intelligently, please give the following information:

EMPLOYED BY.....

TYPE OF PRESENT WORK.....

SCHOOL BACKGROUND.....

ELECTRONICS EXPERIENCE.....

IN WHAT BRANCH OF ELECTRONICS ARE YOU MOST INTERESTED?

CHANNEL MASTER

steers you to the
greatest
conical values
ever offered!

the New
"MAVERICK"

Never before such
a complete line
of conicals at such
fabulous **LOW PRICES!**

Low-priced conicals? Here is the **LOW-EST-PRICED**, fullest conical line you've ever seen—a complete series of 22 different models. Checked out and approved by the Channel Master laboratory, every "MAVERICK" antenna provides outstanding Broad Band reception wherever conical antennas find application. Available both "Super-sembled" and non-assembled, the "MAVERICKS" are, without doubt, today's most sensational antenna buy.

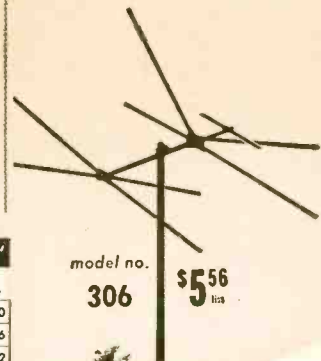
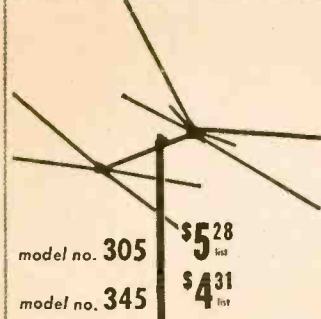
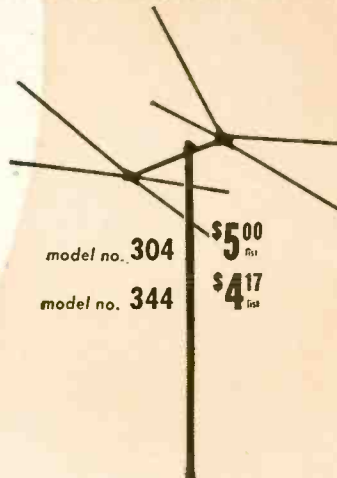
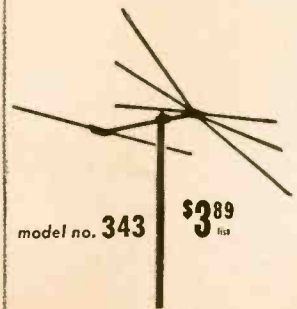
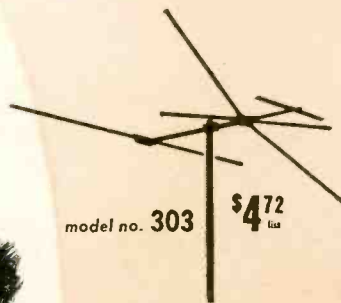
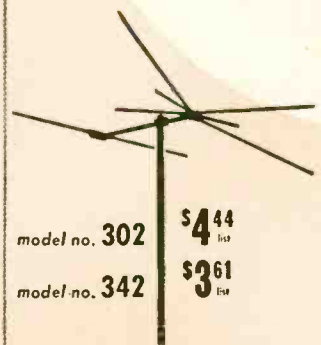

"MAVERICK 300"

model no.	desc.	pack'd	list
301	1-Bay	6	\$4.17
301-2	2-Bay	3	8.75
301-8	2-Bay	1	9.31
302	1-Bay	6	4.44
302-2	2-Bay	3	9.31
302-8	2-Bay	1	9.86
303	1-Bay	6	4.72
303-2	2-Bay	3	9.86
303-8	2-Bay	1	10.42
304	1-Bay	6	5.00
304-2	2-Bay	3	10.42
304-8	2-Bay	1	10.97
305	1-Bay	6	5.28
305-2	2-Bay	3	10.97
305-8	2-Bay	1	11.53
306	1-Bay	6	5.56
306-2	2-Bay	3	11.53
306-8	2-Bay	1	12.08
301-3	Conn. Rods		.56

"MAVERICK 340"

model no.	desc.	pack'd	list
341	1-Bay	6	\$3.50
341-2	2-Bay	3	7.36
341-8	2-Bay	1	7.92
342	1-Bay	6	3.61
342-2	2-Bay	3	7.64
342-8	2-Bay	1	8.19
343	1-Bay	6	3.89
343-2	2-Bay	3	8.19
343-8	2-Bay	1	8.75
344	1-Bay	6	4.17
344-2	2-Bay	3	8.75
344-8	2-Bay	1	9.31
345	1-Bay	6	4.31
345-2	2-Bay	3	9.03
345-8	2-Bay	1	9.58
341-3	Conn. Rods		.56



"MAVERICK 300"

12 different models

Extra "sleeve" on element provides 400% greater strength where it is needed most.

Conical "head."

The **first and only** full line of conical antennas completely *"Super-assembled"*

No hardware, no tools, no tightening—pops open, ready for the mast!

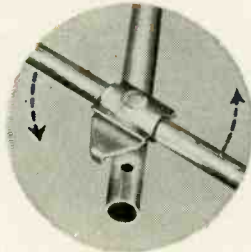

Director bracket.

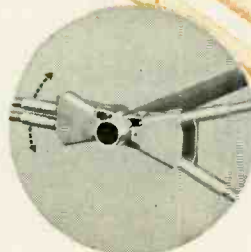

Bracket of X-type reflector.

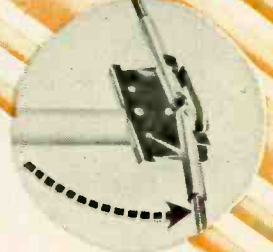

Bracket of straight-bar reflector.

"MAVERICK 340"

10 different models

Features

"NOTCH-LOCK"

Clamp Plate
Elements can't turn or twist loose!

This exclusive feature, until now, has been available only in much higher-priced models.

NON-ASSEMBLED*

This quality line carries the lowest price-tags ever seen on conical antennas!

- Installs in a matter of minutes. • Most popular conical arrangements.
- Finest materials; durable, rugged construction.

* Extra Preassembly Feature!

On all models with straight-bar reflectors, the reflector element is completely preassembled for snap-open installation.



CHANNEL MASTER CORP.
ELLENVILLE, N. Y.



"555" metal-cased MULTIMETERS

an instrument
of
**PERMANENT
ACCURACY**

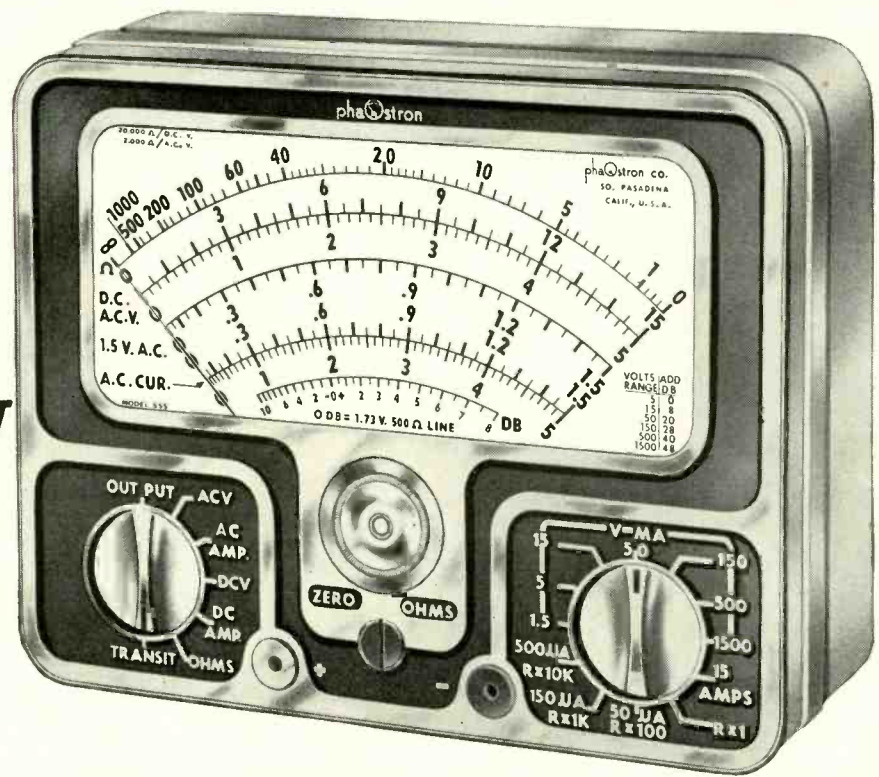

in a case
that
**WON'T
BREAK**

POCKET SIZE WITH A 4 7/8" LENGTH SCALE

WE LEAVE IT TO YOU

WOULD YOU BUY A PLASTIC-CASED WRIST WATCH . . .
if you could buy the finest movement in a magnetically shielded metal case?

Phaotron, world famous manufacturer of ENVIRONMENT FREE PRECISION AIRCRAFT EQUIPMENT for Military and Industrial uses introduces a new concept in Multimeters. This magnetically shielded, metal-cased "555" compares with plastic-cased multimeters as a fine watch in a precious metal case would compare with a plastic wrist watch.

The shielded, shatterproof and anti-magnetic case insures continued accuracy and integrity of this instrument for years to come.

Phaotron "555" Multimeter incorporates more ranges, including AC current, greater visibility, simplified and functional controls and the greatest value offered to date.

See the Phaotron "555", note its many outstanding features, its beautiful satin chrome case, its compactness and light weight, and you will know why

"YOU CANNOT BUY BETTER"

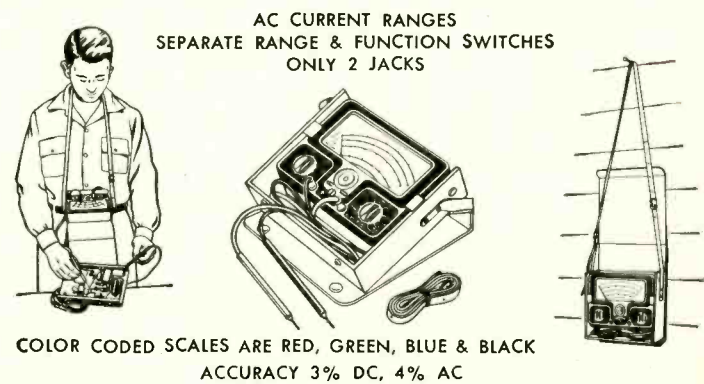

AC CURRENT RANGES
SEPARATE RANGE & FUNCTION SWITCHES
ONLY 2 JACKS

COLOR CODED SCALES ARE RED, GREEN, BLUE & BLACK
ACCURACY 3% DC, 4% AC

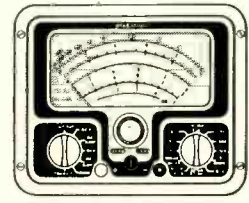

PANEL MOUNTING ADAPTER \$1.50

GENUINE LEATHER CARRYING CASE
\$5.95

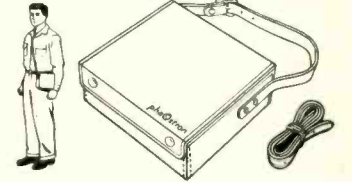

"555" MULTIMETER
complete with probes and batteries
at your **PARTS DISTRIBUTOR**

\$39.95

Manufactured by PHAOSTRON COMPANY • 151 Pasadena Avenue • South Pasadena, Calif., U.S.A.

Home Study Courses in TELEVISION SERVICING offered by RCA INSTITUTES



Study Television Servicing—from the very source of the latest, up-to-the-minute TV and Color TV developments. Train under the direction of men who are experts in this field. Take advantage of this opportunity to place yourself on the road to success in television. RCA Institutes, Inc. (A Service of Radio Corporation of America), thoroughly trains you in the "why" as well as the "how" of servicing television receivers.

FIRST HOME STUDY COURSE IN COLOR TV SERVICING

Now you can train yourself to take advantage of the big future in Color TV. RCA Institutes Home Study Course covers all phases of Color TV Servicing. It is a practical down-to-earth course in basic color theory as well as how-to-do-it servicing techniques.

This color television course was planned and developed through the combined efforts of instructors of RCA Institutes, engineers of RCA Laboratories, and training specialists of RCA Service Company. You get the benefit of years of RCA research and development in color television.

Because of its highly specialized nature, this course is offered only to those already experienced in radio-television servicing. Color TV Servicing will open the door to the big opportunity you've always hoped for. Find out how easy it is to cash in on Color TV. *Mail coupon today.*

SEND FOR FREE BOOKLET

Mail coupon in envelope or paste on postal card. Check course you are interested in. We will send you a booklet that gives you complete information. No salesman will call.



RCA INSTITUTES, INC.
A SERVICE OF RADIO CORPORATION of AMERICA
350 WEST FOURTH STREET, NEW YORK 14, N. Y.



HOME STUDY COURSE IN BLACK-AND-WHITE TV SERVICING

Thousands of men in the radio-electronics industry have successfully trained themselves as qualified specialists for a good job or a business of their own—servicing television receivers. You can do this too.

This RCA Institutes TV Servicing course gives you up-to-the-minute training and information on the very latest developments in black-and-white television.

As you study at home, in your spare time, you progress rapidly. Hundreds of pictures and diagrams, easy-to-understand lessons help you to quickly become a qualified TV serviceman.

There are ample opportunities in TV, for radio servicemen who have expert training. Mail coupon today. Start on the road to success in TV Servicing.

MAIL COUPON NOW

RCA INSTITUTES, INC.
Home Study Dept. RE-4-55
350 West Fourth Street, New York 14, N. Y.

Without obligation on my part, please send me copy of booklet on:

- Home Study Course in TELEVISION SERVICING
 Home Study Course in COLOR TV SERVICING.

Name _____ (please print)

Address _____

City _____ Zone _____ State _____

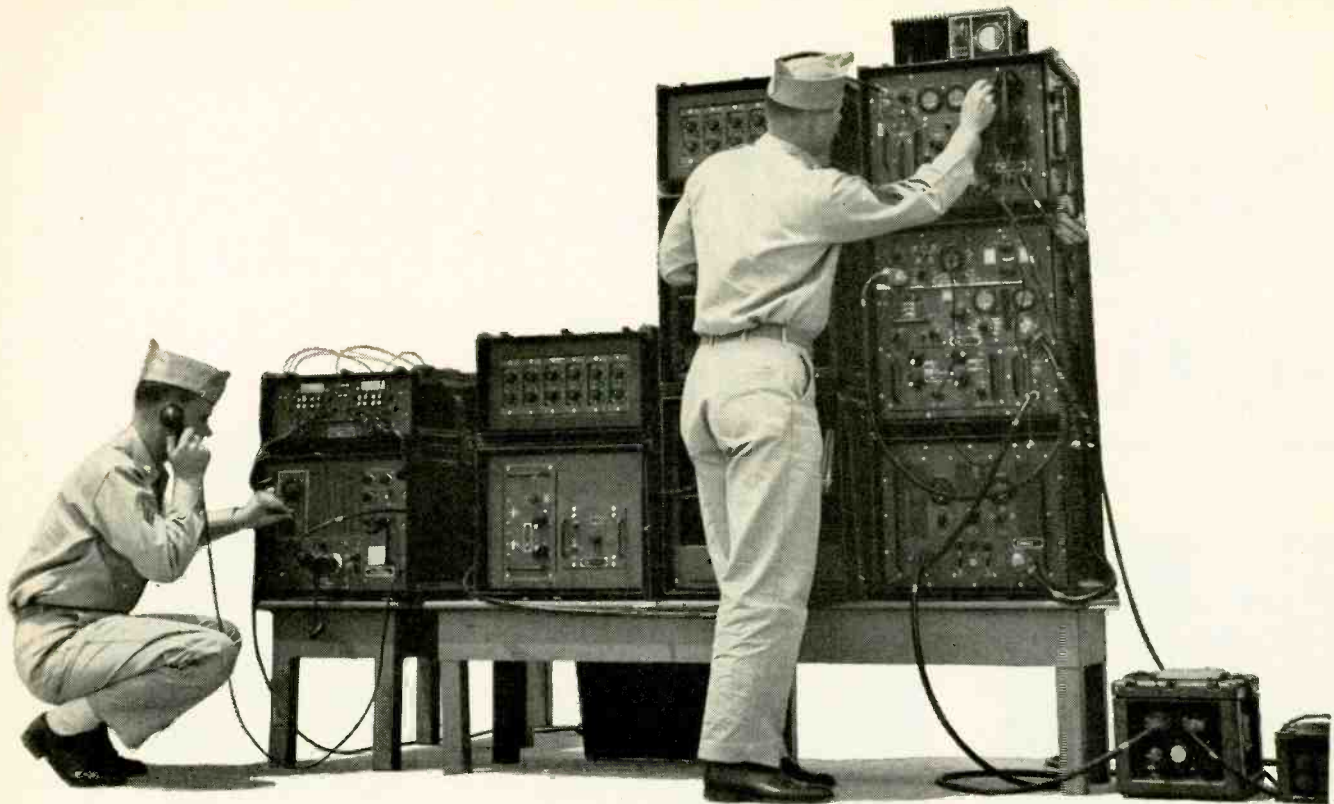

Tuning in for radio transmission. Each item of equipment is not much bigger than a suitcase.

A leapfrog telephone system for the Armed Forces!

A new communications system, which takes to the air when water or rough terrain prevents the stringing of wires, has been developed for the U.S. Signal Corps by Bell Telephone Laboratories.

The system uses cable and radio relay interchangeably over a 1000-mile range. It is easily portable, unaffected by climate, and rugged enough for global use. Twelve voices travel at once over a pair of wires or radio waves—as clearly and naturally as over the regular telephone system.

This is the first time a completely integrated wire and radio system of this large a channel capacity has been available for tactical use by the Armed Forces. It is already in production at Western Electric, manufacturing and supply unit of the Bell System.

The new system is a joint achievement of the Signal Corps, Bell Laboratories and Western Electric... one of the many results of long and fruitful co-operation. It shows again how techniques which the Laboratories develop contribute to our national strength.



Bell Telephone Laboratories

*Improving telephone service for America provides careers
for creative men in scientific and technical fields*



Amplifiers like this are used every 5¾ miles in the cable portions of the system. They are weatherproof, can be used on a pole or the ground, and will even work under water. The system uses a spiral wound cable developed by the Signal Corps.

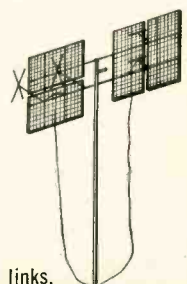

Easily raised antennas
send or receive for the radio links.

LOOKING FOR JOB SECURITY AND SUCCESS?

LET MY STUDENTS AND GRADUATES TELL YOU —

ABOUT MY TRAINING —

\$60 A WEEK IN SPARE TIME



I have the skill and know-how to do the work I love best and to enjoy better things in life, thanks to RTTA. I am working at TV servicing and making \$60 a week sparetime.

Harold Gimlen, Flint, Mich.

HAS OWN BUSINESS



I have a shop at home and have been working on radio and TV after working hours of my regular job. I average \$50 a week for this part time work. RTTA training helped me in making extra money and giving me experience in the electronic field.

Richard Hennis, Little Rock, Ark.

AIRCRAFT INSPECTOR



With RTTA training and through repairing radios and televisions for the right people at the right price, I was able to make the right contacts. I am now an Inspector for Douglas Aircraft at about \$125 a week.

Hugh Maddox, Los Angeles, Calif.

SERVICE MANAGER



I manage two radio and television shops, one here and one in Pompano Beach. RTTA training increased my knowledge of TV circuits and showed me new, quicker methods of repairing. Lessons as presented are very concise and clear.

William Phillips, Fort Lauderdale, Fla.

ELECTRICAL TESTER



RTTA training has helped me understand TV and many variations of simple circuits. The course covers all subjects very clearly. I am now an Electrical Tester for Western Electric Co. at \$83.42 a week.

Raymond Lapan, Burlington, N. C.

REPAIRED EVERY SET



RTTA training helped me to understand TV more thoroughly. I have repaired every set that I was called on to repair.

Andrew Busi, Jr., Iselin, Pa.

L. C. Lane, B.S., M.A.
President, Radio-Television Training Association. Executive Director, Pierce School of Radio & Television.



— ABOUT MY EQUIPMENT

YOU GET ALL THIS EQUIPMENT AND MORE



"... a money making little gem."

I have completed kit #6 and was amazed at how it works. I showed it to a friend of mine and he asked me to set it up for one of the picnics his social club was having. That sure is a money making little gem.

John Fernandez, Fresno, Calif.

"We get excellent pictures..."

I would like to compliment you on an excellent and complete course. We get excellent pictures on my TV set from WSYR (Syracuse, N.Y.), approximately 110 air miles away. The set is working good and I have had to replace only three tubes since I assembled it two years ago.

Larry H. Stafford, Kingston, Ont., Canada

"... very good reception..."

I have really enjoyed the course and have come a long way in TV servicing. I am getting very good reception on my TV station considering that the nearest VHF station is 120 miles.

J. W. Hanlon, Jr., Henderson, Texas

YOU, TOO, CAN GET A BETTER-PAYING JOB IN THE EVER-EXPANDING RADIO-TELEVISION-ELECTRONICS FIELD

Why limit yourself and your earnings because of your lack of training. Learn **AT HOME** in your **SPARE TIME** to be an electronic technician, television repairman, or studio technician. You don't need any experience whatsoever. Many students earn up to \$25 weekly in spare time while learning.

After you finish my Radio-FM Television Course or FM-Television Course you can have, if you want it, two weeks of laboratory training at my associate resident school in New York City—AT NO EXTRA COST.

If you have had previous radio and television experience you can take my practical TV Cameraman and Studio Technician Course to qualify for a good-paying job in a TV studio.

Write to me today and let me show you how you can begin now to put yourself on the road to a better future.

VETERANS!

My school fully approved to train veterans under new Korean G.I. Bill. Write discharge date on coupon.

Radio **T**elevision **T**raining **A**ssociation

52 EAST 19th STREET • NEW YORK 3, N. Y.

Licensed by the State of New York • Approved for Veteran Training

YOU GET ALL FOUR **FREE**



MAIL THIS COUPON TODAY! NO SALESMAN WILL CALL

Mr. Leonard C. Lane, President
RADIO-TELEVISION TRAINING ASSOCIATION Dept. R-4
52 East 19th Street, New York 3, N. Y.

Dear Mr. Lane: Mail me your NEW FREE BOOK, FREE SAMPLE LESSON, and FREE aids that will show me how I can make BIG MONEY IN TELEVISION. I understand I am under no obligation and no salesman will call.

(PLEASE PRINT PLAINLY)

Name _____ Age _____

Address _____

City _____ Zone _____ State _____

I AM INTERESTED IN:

- Radio-FM-TV Technician Course
 FM-TV Technician Course
 TV Cameraman & Studio Technician Course

VETERANS!

Write discharge date

a complete NEW line!

RADIART SEAL·VENT Communication Vibrators

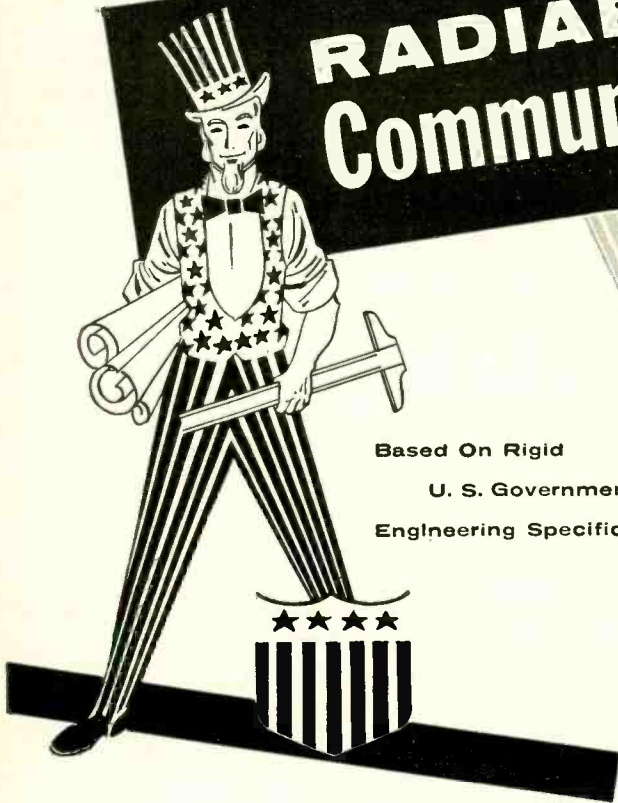

Based On Rigid
U. S. Government
Engineering Specifications

NOW...RADIART makes available to commercial users of communications equipment, a new line of vibrators based upon experience of producing over 2 million similar units to the exacting requirements of U. S. Signal Corps Specifications.

It's ready now!

The new 1955

Radiart Vibrator

Replacement Guide

These Eight Types Offer Complete Replacement for ORIGINAL Communication Equipment:

Old No.	New No.
5515	5715
5518	5718
★	5721
★	5722
5605	5805
5620	5820
5621	5821
5622	5822



SUBSIDIARY OF



THE **RADIART** CORPORATION
CLEVELAND 13, OHIO

TV ANTENNAS • AUTO AERIALS • VIBRATORS • ROTORS • POWER SUPPLIES

THE BEST GENERATOR BUY IN THE WORLD

EICO

NEW! SIGNAL GENERATOR #324

KIT \$26.95 WIRED \$39.95

- ★ Expanded frequency range: 6 fundamental bands: 150-400 kc, 400-1200 kc, 1.2-3.5 mc, 3.5-11 mc, 11-37 mc, 37-145 mc, 1 harmonic band 111 mc-435 mc.
- ★ $\pm 1.5\%$ frequency accuracy; 6:1 vernier tuning knob & excellent spread at most important alignment frequencies.
- ★ Etched tuning dial, plexiglass windows, edge-lit hairlines.
- ★ Variable depth of int. mod. 0 to 50% by 400 cps Colpitts osc.



You could pay scores of dollars more and not get all the advances EICO gives you in the new Model 324—today! Compare . . . and you'll buy EICO!

- ★ Variable gain ext. mod. ampl.; only 0.8 v for 30% mod.
- ★ Colpitts RF osc., directly plate-modulated by cathode follower for improved modulation.
- ★ Turret-mounted, slug-tuned coils.
- ★ Fine & Coarse (3-step) RF attenuators; 50-ohm output Z.
- ★ RF output 100,000 uv; AF output to 10 v.
- ★ Uses 12AU7, 12AV7, sel. rect.; xfmr-operated.
- ★ Supplied with shielded output cable.
- ★ Satin aluminum panel and grey wrinkle steel case.



You could spend 2 and 3 times more and not get all the advanced engineering features of these VTVMs. Compare . . . and you'll buy EICO!

Dual Purpose
UNI-PROBE

A half turn selects
DC or AC - Ohms.

THE BEST VTVM BUYS IN THE WORLD

EICO

NEW! PEAK-TO-PEAK VTVM #232, complete with Uni-Probe (Pat. Pend.)

KIT \$29.95

Wired \$49.95

- ★ Measures directly p-p voltage of complex and sine waves: 0-4, 14, 42, 140, 420, 1400, 4200 volts p-p.
- ★ DC/RMS sine voltage ranges: 0-1.5, 5, 15, 50, 150, 500, 1500 volts. Reads up to 30,000 V. with HVP probe.
- ★ Resistance ranges: 0.2 ohms to 1000 megs in 7 ranges.
- ★ 7 non-skip ranges on every function.
- ★ 4 functions: +DC Volts, -DC Volts, AC volts, Ohms,
- ★ Uniform 3 to 1 scale ratio for extreme wide-range accuracy.
- ★ Large 4½" meter in can't-burn-out circuit.
- Calibration without removing from cabinet.

- ★ Zero-center for TV-FM discriminator alignment.
- ★ One zero-adjustment for all functions and ranges.
- ★ Frequency response: 30 cps-3mc (up to 250mc with PRF probe).
- ★ 1% precision ceramic multiplier resistors.
- ★ Exceptional circuit stability and accuracy.
- ★ New compact size for extra-easy portability (8½x5x5")
- ★ Smart professional styling—new satin finish etched panel with contrasting knobs and meter and grey wrinkle steel case.
- ★ Leather handle.

EICO

NEW! DELUXE PEAK-TO-PEAK VTVM #249 with
7½" Meter and exclusive UNI-PROBE* (pat. pend.)
KIT \$39.95 WIRED \$59.95

All the outstanding & exclusive features of Model 232—plus the extra convenience and readability of its big 7½" meter. An ideal bench instrument.



84 Withers Street • Brooklyn 11, N. Y.

Write for FREE Catalog CG-4

© 55 Prices 5% higher on West Coast

TURN PAGE FOR OTHER EICO INSTRUMENTS

**FREE 1955
EICO CATALOG!**
Tells you how to **SAVE 50%** on
your test equipment costs!

EICO
THE LARGEST MANUFACTURER OF ITS KIND IN THE WORLD

**KITS
INSTRUMENTS**

THE INDUSTRY'S MOST COMPLETE LINE OF KITS & INSTRUMENTS
1/3 MILLION EICO INSTRUMENTS IN USE THE WORLD OVER -
SAVE 50% - BUILD 'EM IN ONE EVENING...THEY LAST A LIFETIME

The Exclusive **EICO** Make-Good
GUARANTEE

Each EICO Kit and Instrument is doubly guaranteed by EICO and your jobber. In case with only selected quality components, EICO guarantees to replace any component which might become defective in normal use if returned to the factory within 90 days of purchase. EICO guarantees all kits assembled according to EICO's simplified instructions will operate as specified therein. EICO guarantees service and calibration of every EICO Kit and Instrument at the nominal charge as stated in the instructions.

ELECTRONIC INSTRUMENT CO., INC.
Test Equipment Manufacturers
84 WITHERS STREET, BROOKLYN 11, N. Y.

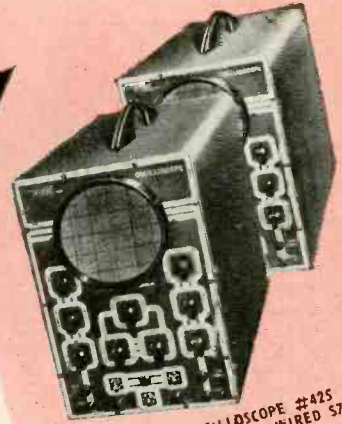

5" PUSH-PULL OSCILLOSCOPE #475
KIT \$44.95
NEW! #470 7" PUSH-PULL OSCILLOSCOPE
KIT \$79.95 WIRE \$79.95

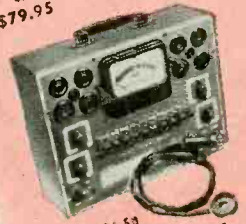

CRA . . . \$4.50
TUBE TESTER #625
KIT \$34.95 WIRE \$49.95



20,000 Ohms/Volt
MULTIMETER #365
KIT \$24.95
WIRE \$29.95



1,000 Ohms/Volt
MULTIMETER #336
KIT \$12.90
WIRE \$14.90



NEW! #232 PEAK-TO-PEAK
VTVM with DUAL-PURPOSE
AC/DC UNI-PROBE (pat. pend.)
KIT \$29.95 WIRE \$49.95

NEW! #249 DELUXE
PEAK-TO-PEAK VTVM with 7 1/2"
METER & UNI-PROBE (pat. pend.)
KIT \$39.95 WIRE \$59.95



VACUUM TUBE VOLTMETER #221
KIT \$25.95 WIRE \$39.95
DELUXE VTVM (with 7 1/2"
METER) #214
KIT \$34.95 WIRE \$54.95



R-C BRIDGE & R-C-L
COMPARATOR #950B
KIT \$19.95 WIRE \$29.95



MULTI-SIGNAL
TRACER #145
KIT \$19.95
WIRE \$28.95



DELUXE RF SIGNAL
GENERATOR #315
KIT \$39.95 WIRE \$59.95

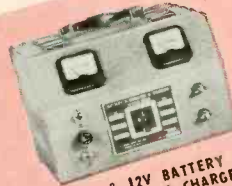

6V & 12V BATTERY
ELIMINATOR & CHARGER
#1050
KIT \$29.95 WIRE \$38.95



NEW! #44 FLYBACK
TRANSFORMER & YOKE
TESTER
KIT \$23.95
WIRE \$34.95



RF SIGNAL GENERATOR #320
KIT \$19.95 WIRE \$29.95



TV/FM SWEEP GENERATOR #360
KIT \$34.95 WIRE \$49.95

SMC-4.5MC CRYSTAL
\$3.95 ea.

A PROBE FOR EVERY PURPOSE

EICO

See the famous EICO line at your jobber today
SEND FOR FREE CATALOG C-4
ELECTRONIC INSTRUMENT CO., Inc.
84 Withers Street • Brooklyn 11, N. Y.
Prices 5% higher on West Coast

ATOMELECTRONICS IN 1980

... *The new art will soon be a giant* ...

SINCE the advent of the atomic age early in the 1940s, the wedding of atomics with electronics has blossomed into an important new art. This is but natural, because the electron is an integral part of the atom — neither can exist without the other. "Atoms for Peace" will not be an idle hope by 1980, twenty-five years hence — indeed, it may well be the greatest civilizing force humanity has ever experienced.

The reason for this is found in the tremendous energies locked up in the atom — a power that now is beginning to be set free for the emancipation of mankind.

We already have actual working prototypes of atomic batteries in use today — scientific toys, to be sure, just like Volta's battery of 1800. It, too, was a toy, but nevertheless the forerunner of the electrical age of the twentieth century.

The great difference between the two batteries is that the galvanic type transforms chemical energy into electricity in comparatively small quantities, while the atomic type — due to its vastly greater inherent power — gives us atomic-generated electrical energy, not for a few puny hours, but for many years continuously.

We must be careful at this point to differentiate always between present-day atomic power plants and future ones of 1980. Today, we obtain atomic power in a roundabout manner, by using *only* the thermal or heat effects of the atomic reaction. We go back to the ancestral steam engine by heating a boiler with atomic energy and finally running an electric generator with it. As beautiful a twentieth-century anachronism as you will ever find!

The thermal reaction of the atomic pile is in reality an undesirable one from the energy viewpoint — and, indeed, the atomic engineer of the future will try to eliminate it as far as possible. The reverse is true today — we use the atom *only for heat purposes* and suppress its far greater energy — *the electromagnetic power* — by useless, massive shielding. It is precisely here that the great strides of the future will be made, and the atomic battery — predicted by the writer in 1945 — points the way. *The atomic energy of 1980 will be mostly electrical*, not thermal, except for specialized purposes where it will be more practical to use direct atomheat.

Automobiles, motorbikes, pistonless airplanes, locomotives, power plants, all will run on *directly* generated atomelectric energy. So will most portable tools and appliances, which will have a tiny inbuilt atomelectric power supply.

The same will be true of our radios and tele-

vision receivers, none of which will depend upon the present-day electric house current.

Possibly the greatest boom of atomelectronics will come through new and highly perfected future semiconductors, intimately linked *directly* to the atom. We have already made laboratory and experimental models of atom-powered transistors; this is but a beginning, with revolutionary advances certain to follow in the not-too-distant future.

The greatest engineering development will come in the extensive simplification of most of our electronic instrumentation. Our radios and television sets by 1980 will bear little resemblance to present-day ones. They will in the main be tubeless and transformerless. Even the capacitors and resistors will be unrecognizable by today's standards. Much of the wiring will have disappeared: integral *self-components* will be directly fashioned into a homogeneous block. Hence, the present-day bugaboo of loose connections will largely fall by the wayside. This will then be the service technician's paradise.

Recent radio-astronomical research tends to show more and more that radio waves in free space are created atomelectronically. This means nothing less than *instrumentless transmitters*. Imagine an almost weightless yet powerful radio transmitter! Translate this into a mundane portable broadcasting unit the size of a matchbox, and you can visualize the great possibilities. The day will come when all of us will be able to carry a miniature compact dial phone in our pocket for instant communication with the entire world. A tiny buzzer will "ring you" via your pocket phone, no matter where you are, for instant, world-wide *personalized* communication.

Far more important than all this, however, will be the atomelectronic role in the coming great emancipation of the world's underprivileged and starved populations—a vast reservoir of potential communism.

We can visualize tens of thousands of special atomelectric farm tractors all over the world which do not require refueling for years. They can sow and reap automatically by means of modified computers and photocells, moving back and forward between special rows of markers which flag the photocells. These tractors will also furnish all the energy for even the largest farms, supplying them with light and power for every imaginable purpose.

One hundred thousand such tractors, opening new farmlands on the five continents, could do away with the ageless starvation threat and bring prosperity to every land under the sun.—H. G.



HORN-TYPE

SPEAKER SYSTEMS

By GEORGE L. AUGSPURGER

*Part I—Fundamentals of horn
speakers; the folded horn; in-
troduction to the corner horn*

THE salesman pointed out enthusiastically that only with horn loading could a high-fidelity speaker system give true distortionless bass response. "Just listen to those low notes," he said. "That's the real thing. No more of that boomy juke-box bass."

All of which was common enough sales talk except that the man happened to be selling juke boxes.

Another demonstrator explained that his product used real Klipsch-licensed folded-horn construction. Said he, "We don't believe in the boomy resonant bass you get with bass-reflex systems." He pointed to a little cabinet about the size of a cigar box which sounded very much like a bass-reflex system. "Nowadays," he chortled, "anyone can afford genuine corner-horn reproduction with the 'Little Gargoyle' portable corner horn."

You may have recognized the scene as one of the recent audio fairs. Except for a few stubborn manufacturers who retained modified bass-reflex or R-J enclosures, it seemed that you were simply nowhere unless you had some sort of "four-dimensional reintegrated axis nonparallelepiped corner horn" to offer the panting audiophiles.

Horns have been used as integral parts of musical instruments for years. The horn in reverse, used as a somewhat obvious candid microphone, transmitting conversations to an eavesdropper in another chamber, was a plaything in the time of Leonardo da Vinci, and came down to us as the ear trumpet—the first hearing aid. When a sound-reproducing device was finally

invented, it was inevitable that a horn would be used to amplify the delicate shudders of its tiny diaphragm. I say inevitable because at that time, prior to any sort of electronic audio equipment, the horn was the only known method of coupling a small vibrating reed or diaphragm to the surrounding air. And in that word "coupling" lies the whole secret of the horn.

Nowadays even the greenest audiophile knows that a horn is an acoustic coupling device similar to a transformer in electrical circuits. The bass response of a horn depends both upon its rate of flare and its mouth area. An exponential horn which doubles its cross-sectional area every foot is said to have a 60-cycle flare. If it doubles every 2 feet, its flare is said to be 30 cycles, and so forth. If the horn is mounted in a flat wall, the mouth diameter should be equal to at least one-quarter the wavelength of the lowest frequency to be reproduced. If the same horn is mounted at the intersection of two walls, the mouth area can be cut in half. Similarly, if mounted at the intersection of two walls and ceiling or floor, the mouth area can be reduced to one-quarter that of the flat wall model.

All these rules are derived mathematically in Olson's *Elements of Acoustical Engineering*, or one can use the optical analogy of Gately to construct the effective mouth diameter of a particular design as in Fig. 1. But this isn't the only space-saving trick handed us by the acoustic engineers. The horn need not be straight—it can be bent, folded, curled, split or tied

in knots—à la Sousaphone. Furthermore, the cross-section need not be circular. The horn can be triangular, square, rectangular, hexagonal or shaped like an "F" slot. (The last configuration is especially good for snob-appearance installations.)

The various configurations possible and the basic design considerations behind them were covered in an article in the November, 1951, issue of *Audio Engineering*. In that article I made the point that, all other things being equal, a straight horn is preferable to a folded model. Since the publication of that manuscript there have been placed on the market, by actual count, over 30 folded, curled, twisted, knotted or kneaded exponential horns of various shapes and sizes. One straight horn has appeared. Of course, the argument of straight *versus* folded horns always resolves itself once the problem of size arises, since a full-sized straight horn is a monstrous affair.

The folded design isn't the only compromise made in the interests of expediency. All the configurations now on the market are built with the following assumptions being taken for granted:

1. The wave front in a horn is a plane surface perpendicular to the axis of the horn for relatively small rates of flare.
2. Bends or folds in themselves will not introduce objectionable distortion as long as the cross-section is relatively small at that point.
3. The horn is made of some fictional material which neither transmits nor absorbs any sound at all. (Don't laugh,

this statement is lifted right out of Olson!)

With these design axioms in mind let's take a look at what can be done with the basic exponential flare idea.

Straight exponential horn

With the exception of the familiar horn type tweeter, nobody makes a wide-range unit of this type, so the discussion is practically ended right here. A full-sized horn is shown in Fig. 2 in case you want to build one. Made of concrete block or some such material, this design will perform almost exactly according to theoretical expectations.

Folded horn

Here we begin to get into the region where good designs are often accidental. I don't mean to imply that a great deal of careful preliminary design and sweat are not included in the price of even the least expensive design. My point will become clear, however, if we take a look at a few such horns.

The Frazier-May horn (see photo) is a brand-new addition to the fraternity of folded horns. It is a square wooden variation (Fig. 3) of the re-entrant public-address horn. Naturally the Frazier-May is described as revolutionary and a completely new concept. (These are advertising terms that carry about the same semantic implications as "hello.")

The Frazier-May horn is built of three conic sections driven by an 8-inch cone speaker. The first fold bends around a double partition lined with Fiberglas. This gives a reasonable amount of acoustic insulation between the first two sections of the horn. But in the case of the second fold, a common piece of plywood is used between the terminating sections. It seems reasonable that, if this single barrier transmits any acoustic energy at all, the cabinet is no longer operating as a true horn. To aggravate this acoustic short circuit further, six wooden spacers fasten the two sections of the cabinet together. These spacers probably act just as the bridge in a piano, transmitting vibrations from the inner wall (where sound pressures are fairly high) to the outer shell which now acts as a sounding board in addition to its other function.

The mouth area of the Frazier-May is in the neighborhood of 225 square inches. Since the manufacturer claims a frequency range equal to that of a symphony orchestra, this implies that the horn will reproduce a 30-cycle bass fundamental. Obviously this does not jibe at all with my original rules for optimum mouth diameters, and yet the model 8-50 actually doesn't sound bad.

The paradox has already been explained in the statement that the unit is not operating as a true horn. It is partially a horn, partially a large vibrating sounding board, partially a tuned air column resonating at about

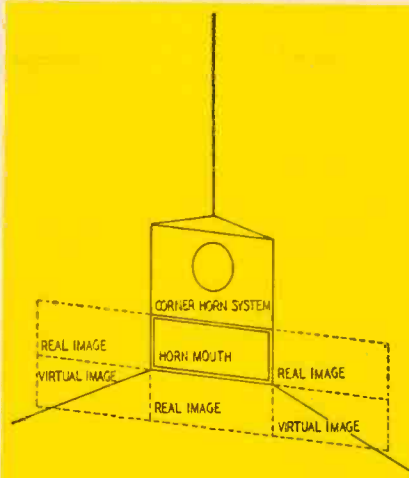

Fig. 1—Constructing effective mouth diameter by plotting reflected images.

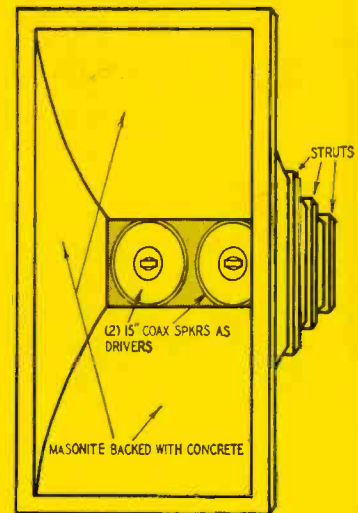

Fig. 2—The straight exponential horn.

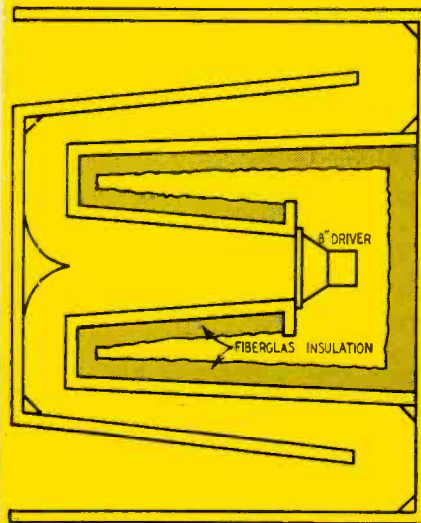

Fig. 3—Interior of Frazier-May horn.

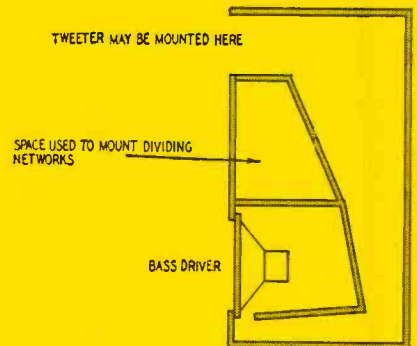

Fig. 4—The Jensen Laboratory Standard.

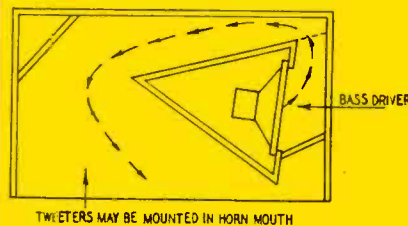

Fig. 5—The University Classic—horn may be mounted vertically or horizontally.

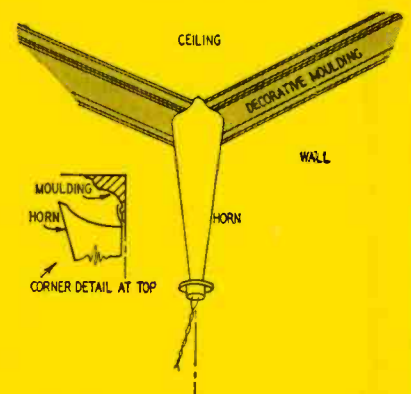
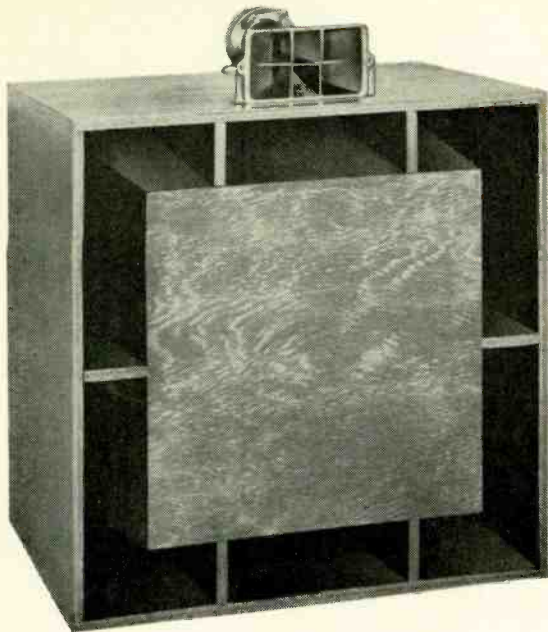
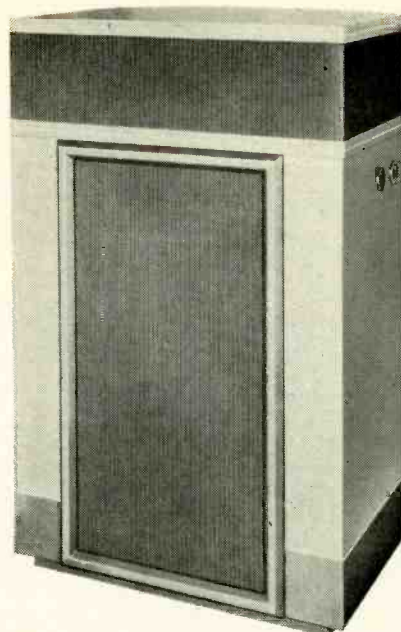

Fig. 6—Ephraim's portable corner horn.



The Frazier-May is a modified re-entrant horn.



Above is the Jensen Laboratory Standard horn.

80 cycles and partially a cluster of separated sound sources mutually coupled. The mutual-coupling principle is a feature its designers make no mention of. (It is discussed in the Permoflux *Diminnette* system described in the October, 1954, issue of RADIO-ELECTRONICS. Due to the mutual coupling effect the 8-50 has a virtual mouth area in all probability of somewhere around 400 square inches. If the wooden spacers were replaced by stand-off bushings the mouth would become a radial-slot sound source and the bass efficiency would probably be increased. I'll talk about the radial slot later on, but to return to the Frazier-May—I may be sticking my neck out by making the guess that some designs are partly accidental, but I can't see any other way to explain the very passible performance of a unit which seems to violate the principles of good exponential horn design.

Another horn type system which achieves its results by departing from basic exponential design is the new Jensen *Laboratory Standard* model RS-100 (Fig. 4). The main difference in approach is that in this case the departure is a deliberate one, carefully calculated. The RS-100 is basically a vertical horn terminating in a horizontal slot mouth. In this case the mouth area, horn length, flare (Jensen uses the refinement of a hyperbolic-exponential formula) and driver cone resonance are all ingeniously juggled in such a way as to give genuine low-distortion response down to 35 cycles.

It is a source of personal satisfaction to me that the *Laboratory Standard* achieves its results in part from a horn which is curved rather than folded and which uses no partition common to two sections of the horn. A thorough analysis of the design of this really excellent speaker is found in the October, 1954, issue of *Audio*

magazine. Since the Jensen is not only considerably more expensive, but seems to be more painstakingly designed than the Frazier-May, I wasn't surprised that to my ears it sounded a good deal more unobtrusive. (The word "unobtrusive," by the way, is rapidly becoming the definitely "all right" term to use in describing the performance of the very finest high-fidelity speaker systems.)

Of course, an exponential horn can be squashed into all sorts of configurations with varying degrees of success, depending generally on the degree to which factors other than true horn loading enhance or detract from the performance of the system. Fig. 5 shows the interior construction of the University *Classic*, representative of folded-horn design.

Almost all these systems, by the way, use horns for mid- and high-frequency sources as well as bass generation. Most of the high-frequency units are carefully, conventionally designed straight exponential units. The horn-type tweeter has become familiar to anyone who knows anything about hi-fi and I suppose that it was because of its very familiarity I forgot about it when I said that nobody made straight horns. All the basic assumptions of horn design are very nearly met in these small horns. The fine performance of the better tweeters indicates that the problem of size, rather than mere engineering conceit, is responsible for the lack of straight exponential bass horns.

Corner horn

There is some squabbling among audio bigwigs as to just who first thought of the idea of a corner horn. The basic concept is simple enough and immediately attractive. The solid angle formed by the intersection of two walls and floor in an ordinary room forms

a conic horn of triangular cross-section. If an exponential horn can be built into the corner in such a way as to couple effectively a loudspeaker to the horn formed by the corner itself, a great saving in space with a corresponding increase in efficiency can be realized.

Audak claims the honor of thinking of this scheme for their own *Maxmillian Weil* and in the opposing camp Paul Klipsch is widely known as the originator of the hi-fi corner horn. However, a Frenchman named Ephraim probably was the first consciously to exploit the corner itself as a conic horn. Ephraim's idea (Fig. 6) was to use a headphone or a diaphragm type driver unit coupled to a conic horn which was then hung in a corner from the decorative molding that usually graced rooms of that period. Voila! . . . a small, portable, true corner-horn system. (On May 25, 1929, E. K. Sandeman filed a patent claim for a "Loud Speaker" that contained ". . . a sound generator located in a corner provided by three planes intersecting each other at right angles to form a solid angle into which the diaphragm discharges . . ." The patent, No. 1,984,550, was issued Dec. 18, 1934.—*Editor*)

Ephraim's patent, while not an exponential horn and definitely not high fidelity as we think of the term, can nevertheless be recognized as the true parent of such systems as the Brociner model 4 and the Lorenz sound corner. Klipsch, on the other hand, approached the concept a little differently and, because his design is much easier to adapt as a piece of furniture, almost all corner horns today are offshoots of the original Klipsch model K introduced in 1941.

In the next installment we will discuss the basic Klipsch design and the numerous commercial variations based on it.

TO BE CONTINUED

Improving Low-Priced Tape Recorders

WELL over 95% of what most people consider pleasurable music lies within the 50–9,500-cycle range. A tape recorder having an essentially flat response over this range at 7.5 i.p.s., no noticeable flutter, very low distortion and a very low noise level is an item of which no high-fidelity system need be ashamed. Yet, unlikely as it may seem, such a recorder can be had for less than \$150 plus several hours of labor. This does not include a power amplifier.

Starting with a Pentron PMD-1, which consists of a transport mechanism and preamplifier (equipped with VU meter) in one case, I made changes resulting in a tape recorder that sounds excellent in comparison with machines costing two or three times as much. The same can be done with other inexpensive tape recorders.

The setup of Fig. 1 was used to plot frequency response and observe waveforms. The v.t.v.m., flat far beyond the audio range, was carefully observed during recording, and the oscillator, which has two outputs, was regulated

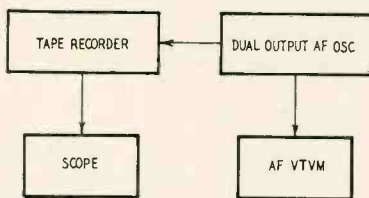

Fig. 1—Equipment setup for measuring a tape recorder's frequency response.

to maintain a 1-volt input to the recorder at all frequencies. Tests were made on Audiotape 1251 (regular) and 1861 (long playing) with no significant differences observed between the two. Frequencies for testing were: between 30 and 100 cycles, 10 cycles apart; between 100 and 1,000 cycles, 100 cycles apart; between 1,000 and 12,000 cycles, 1,000 cycles apart.

To facilitate frequency identification on the oscilloscope during playback, a 50-cycle signal was inserted after 100, 500, 1,000 and 10,000 cycles.

The output of the tape recorder during playback was displayed on the oscilloscope, using a fine-ruled grid screen. A little practice, together with the 50-cycle benchmark, made frequency identification easy. Using 1 kc as a reference frequency, its amplitude was adjusted to fill exactly 20 vertical spaces on the oscilloscope screen. The relative value of all frequencies could then be read with an accuracy of better than 0.5 db. The v.t.v.m. could have been used to measure output amplitude, but the oscilloscope had the advantage of providing frequency recognition as well as indicating distortion.

Part I—Making a preliminary survey; improving the signal-noise ratio; installing new heads; cutting down the hum

By HERMAN BURSTEIN



The Pentron PMD-1 basic tape recorder and the new Dynamu hi-fi recording head.

AUDIO—HIGH FIDELITY

Taking the Pentron PMD-1 as it came, tests showed three areas for improvement:

1. *Smoothness of response.* Although the frequency range was acceptable—3 db down at 60 and 9,000 cycles—response was not smooth. Between approximately 2,000 and 5,000 cycles there was a gradual rise to a peak of about 4 or 5 db. This was confirmed by taping a good-quality LP record, playing back the tape simultaneously with the record and making rapid A-B comparisons between tape and record with a selector switch. The tape had appreciably more treble.

2. *Distortion.* When signals were recorded at the VU level recommended by the manufacturer, there was considerable distortion during playback of frequencies below 500 cycles, especially below 100 cycles. To reduce distortion to an acceptable point, it was necessary to record at levels producing an unsatisfactorily low signal-to-noise ratio.

3. *Signal-to-noise ratio.* It was possible to record the mid-range and treble frequencies at a level producing a tolerable signal-to-noise ratio—one associated with moderate-price tape recorders. However, the recorder was not really quiet in the sense associated with good audio equipment. Tape hiss, preamplifier hum, white noise and other noise were still objectionable at all but very low listening levels.

Before attempting to smooth and possibly extend frequency response I decided to attack the more important problems of distortion and signal-to-noise ratio.

Signal-to-noise ratio and distortion

With the record-playback head and VU meter circuit disconnected, the pre-

amplifier (Fig. 2) was tested and found free of distortion. The PMD-1 has a fair amount of degenerative feedback in the form of unbypassed cathode resistors. An oscilloscope check showed no visible distortion in the range of 20 to 15,000 cycles.

However, with the VU meter circuit restored, there was distortion, particularly of frequencies below 1 kc. A 400-cycle signal recorded at any level was heard in playback with a great deal of harmonic content. Thus the lower notes of a piano had a tinny ring.

The following steps were taken to improve the signal-to-noise ratio and at the same time reduce distortion below audibility:

1. *Substitution of Dynamu heads.* At the 1954 Audio Fair in New York City I saw a demonstration of the recently marketed Dynamu record-playback head (made by Dynamu Magnetics Corp., Minneapolis, Minn.) This miniature head (see photo) provides professional performance in terms of frequency range, distortion, output level, smoothness of low-frequency response, hum pickup and tape hiss.

The head's gap is only .00015 inch wide, compared with widths of .00025 to .0005 inch in other heads, so that under suitable conditions it potentially has a high-frequency playback limit of 25 kc at 7.5 i.p.s. Furthermore, a resonant frequency as high as 85 kc, depending on lead length, enables the head to be most efficient in playback at high frequencies, the ones most subject to attenuation. Not only is the gap extremely narrow, but also extremely straight; the manufacturer claims a deviation of no more than two wavelengths of light from top to bottom. Linearity and narrowness of gap provide a high degree

of resolution in reproducing information on tape. They reduce intermodulation distortion, high-frequency losses due to azimuth misalignment, and distortion and losses produced by flutter and weaving of the tape as it passes the head.

Instead of a dielectric shim, the gap is occupied by electrolytically deposited copper that reduces eddy losses. Miniaturization of the head decreases hum pickup and enables it to perform well in playback at low frequencies, especially those below 50 cycles, where flux changes are very slow. Because it is small, the head is close to the tape and relatively efficient in the low range. Low-frequency response is also extended because the coil is wound very close to the core, improving the coupling between the two.

To investigate the head's performance, I purchased Dynamu kit D801, including erase head, which had just become available for the Pentron 9T3C. (The transport mechanism of the 9T3C and PMD-1 are substantially the same.) Similar Dynamu kits are available for many of the popular tape recorders.

Precise positioning of the heads is necessary, requiring a ruler accurate to 1/64 inch. The heads are half-track and must be mounted with respect to the tape and each other so that they function on the lower track of the tape. Moreover, the height of the tape guides should be set to run tape to the reels without scraping the top or bottom of the reels. The heads were therefore mounted slowly and carefully.

To replace the original Pentron heads it was necessary to remove the black plastic cover over them. This procedure is tricky in the case of the PMD-1. First, take off the two oblong knobs attached to the idle-run and wind-rewind control shafts; then unscrew the hexagonal nuts on these shafts, enabling the black metal cover over the shafts to come off. Second, remove the five perimeter screws on the copper plate of the transport mechanism. Third, remove the feed and takeup spindles by taking off the pulleys attached to them beneath the chassis of the transport mechanism. These steps permit removing the copper plate on top of the transport, and attached to the plate is the plastic cover that is over the tape recorder heads.

Connecting the shield wire of the record-playback head to ground, as instructed, produced a large amount of hum pickup. However, when the shield wire was left floating, satisfactory results were obtained. Connecting the red lead of the record-playback head to ground gave minimum hum pickup. Azimuth alignment was at first performed by eye, although, as described in the section on frequency response, an accurate alignment was later made. For proper contact between tape and heads, the felt pressure pads were detached, carefully trimmed to fit the new heads, and reglued.

The Dynamu heads call for an oscil-

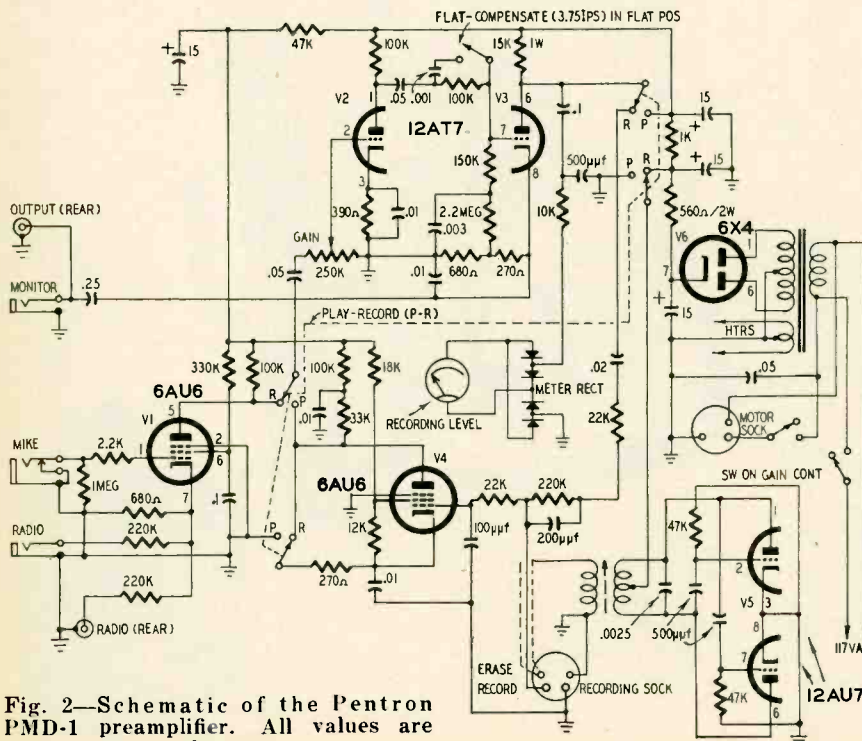

Fig. 2—Schematic of the Pentron PMD-1 preamplifier. All values are shown.

lator frequency of 60 to 100 kc. A frequency of 96 kc was obtained by replacing the .0025- μ f capacitor across the primary of the oscillator coil with a .001- μ f ceramic capacitor and turning the oscillator-coil slug nearly all the way out. A change in wiring was required to supply the correct amounts of bias current to the Dynamu erase and record-playback heads. Fig. 2 shows that the original Pentron circuit feeds bias current to the record-play-

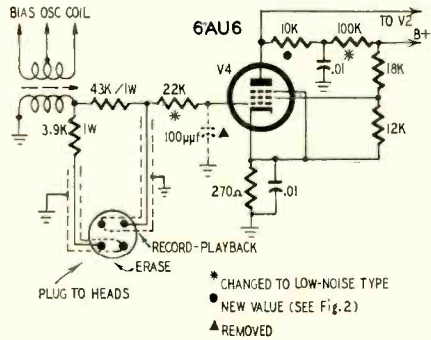

Fig. 3—Schematic of the first stage of the modified Pentron playback circuit.

back head via the capacitance between the hot lead to this head and that to the erase head. As shown in Fig. 3, separate coaxial cables were run to the two heads, and the correct amount of current to each was supplied through limiting resistors. To minimize capacitance across the record head, Belden 8401 cable, with a capacitance of only 25 μ f per foot, was used to feed signals and bias current from the preamplifier to the record-playback head.

Changes in bias current through the erase head have a significant effect upon current through the record-playback head. Since the record-playback head current is the more critical, the limiting resistor for the erase head was determined first. The Dynamu erase head should be fed a maximum of 13 ma. A 3,900-ohm 1-watt resistor provided this current. Dynamu recommends a bias of 0.4 to 0.8 ma for the record-playback head. I decided to use the higher figure because distortion decreases with increased bias current. Therefore, a 43,000-ohm limiting resistor was used to supply bias to the record head. To measure bias current to the erase head, a 100-ohm resistor was inserted between the ground lead of the head and ground; the voltage across it was read, and the current calculated. Record-playback head current was similarly calculated by the voltage across a 1,000-ohm resistor. Voltages were read on a high-gain wide-band oscilloscope (flat to about 500 kc), calibrated with accurate voltages from a tube checker.

A preliminary check of the Pentron's performance with the new heads was very pleasing. Program music and speech could be recorded with peaks at about zero on the Pentron's VU meter, whereas previously it had been necessary to keep peaks at about -10 for the same degree of distortion. A tape

recorded at 1 kc with the original Pentron head was played back with the Dynamu head and gave about 6 db more output. Moreover, the Dynamu head produced significantly less hum and tape hiss.

2. *Modification of VU circuit.* I considered either doing without the VU meter or substituting a 6E5 or similar electron-ray indicator to eliminate the distortion caused by loading the VU circuit directly onto the audio signal. However, the Pentron's meter together with the meter rectifier has sufficient bandwidth to be very useful—about 3 db down at 50 and 10,000 cycles. Therefore, I decided to isolate the VU circuit from the audio signal by adding a VU amplifier stage (Fig. 4).

A 6BH6 was selected because it is miniature (the PMD-1 chassis is crowded), inexpensive, and draws only 0.15 ampere filament current. Adequate room to mount a seven-pin socket was found between the 6X4 rectifier and the 6AU6 first record stage.

The values in Fig. 4 are approximately such that when program transients read 0 on the VU meter, the actual transient level is about 6 to 8 db above 0. This is because the meter, a mechanical device, cannot fully follow transients. Tape tests showed that

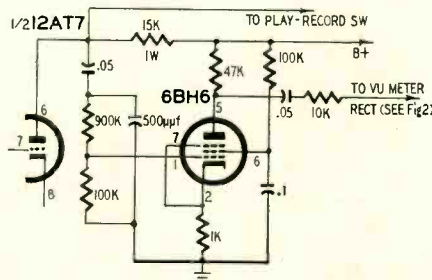

Fig. 4—Amplifier stage for VU meter.

most frequencies could be recorded with negligible distortion at levels 5 to 8 db above 0 on the VU meter. The record stage was monitored by an oscilloscope (the Pentron PMD-1 provides a monitoring jack on the panel), calibrated to read 20 spaces on a grid screen when a 400-cycle signal was fed in at a level 6 db above 0 on the VU meter. Then a live FM program was fed to the tape recorder. Generally when transients reached 0 to 2 db above the calibrated level on the oscilloscope, the VU meter hit about 0.

Professional standards call for the VU meter to have a safety factor of 10 db with respect to transients. In other words, when a steady sine wave of 400 cycles is fed to the record head at a level 10 db below the level which produces maximum allowable distortion, the VU meter should read 0. In practice, the writer and others have found that a safety factor of about 6 db is satisfactory, if judgment is used. For example, in recording material, such as piano music, with very sharp transients, peaks should not exceed -2 or -4 on the meter.

If a somewhat different calibration

of the VU meter is desired, moderate changes in the 900,000-ohm resistor leading to the grid of the 6BH6 would provide the required difference of a few db in meter reading.

3. *Low-noise resistors.* The plate load and grid resistors of the first stage tubes were replaced by Aerovox type CP $\frac{1}{2}$ Carbofilm low-noise precision resistors (Figs. 3, 5). Also, the 47,000-ohm grid resistors of the push-pull bias oscillator (Fig. 2), which uses a 12AU7,

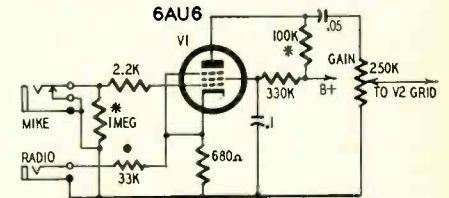

Fig. 5—Schematic of the first stage of the modified Pentron record circuit.

were replaced by Aerovox low-noise resistors. Altogether, six resistors were replaced, resulting in a considerable reduction of white noise. The resistors are available in values within 10% or less of the Pentron design, so that there was no significant change in performance other than noise reduction.

I experimented with the British Z729 pentode, which has characteristics similar to those of a 6AU6, in the attempt to reduce white noise and hum in the first playback stage. Although the Z729 is a nine-pin tube, only seven pins are used. I made an adapter from a seven- and a nine-pin socket and pins fashioned from internal elements of several old and otherwise worthless tubes. It was wired so that Z729 could be inserted via the adapter into a socket wired for a 6AU6. The Z729 produced perceptibly less white noise than the 6AU6; also somewhat less hum. However, the Z729 had about 5 db less gain, so that its initial advantage of less noise was virtually cancelled because the Z729 or 6AU6 is used before the volume control. Consequently the 6AU6 was retained in the Pentron circuit.

4. *Hum reduction.* While the preamplifier of the Pentron PMD-1 is good as to hum level, I found that a worthwhile improvement could be made by adding a 60- μ f 450-volt capacitor to the filter circuit at the junction of the 1,000- and 560-ohm resistors (Fig. 2). It was mounted on the small chassis by strapping it to one of the original filter capacitors with a generous amount of tape.

A further attempt to reduce hum was made by disconnecting the center tap of the filament supply from ground and connecting it at a potential of about 35 volts d.c. Although hum was lowered slightly, a frying noise was introduced. Therefore the attempt was abandoned and the center tap restored to ground. However, in the case of other recorders this hum-reducing method might be more successful.

TO BE CONTINUED



SILENT SOUND

This revolutionary new advance in high-fidelity reception may prove as important as the invention of the telephone receiver

By MOHAMMED ULYSSES FIPS, I. R. E.*

THE other day the big boss called me into his sanctum after lunch. He was smoking one of his eight-inch Havana cigars, after an evidently satisfactory lunch. I noted this immediately because he wasn't scowling, as is his usual custom. Indeed, much to my astonishment, he was in an expansive mood, with a broad smile on his unplowed, rough countenance.

"Fips, my boy," he began his lecture, "sound, the way we work it today, is an anachronism. We haven't invented a new thing in acoustics in thirty years! Then we added insult to injury by taking on high fidelity—I call it *hi-fiddlesticks!* Hi-fi indeed—for whom? Less than half the population can hear above 10,000 cycles. Once you reach 35, your hearing becomes progressively worse. Only the very young hear well, and they are too young to appreciate good music. So what!?!"

"Here we knock ourselves silly with expensive records and equipment, when half of the population doesn't get a thing out of them. It's like sending the inhabitants of a town to a technicolor movie *if half of them are color blind!* What good is that, I ask you?"

"Now let's start at the beginning of broadcasting. What do we do? Do we broadcast audio sound? Of course not. We take the low audible sound and transform it into high-frequency elec-

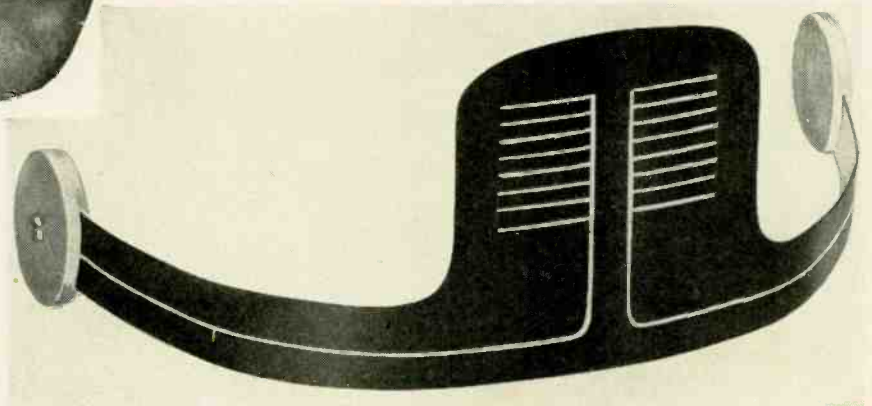

The printed circuit submicrowave antenna and the templepieces.

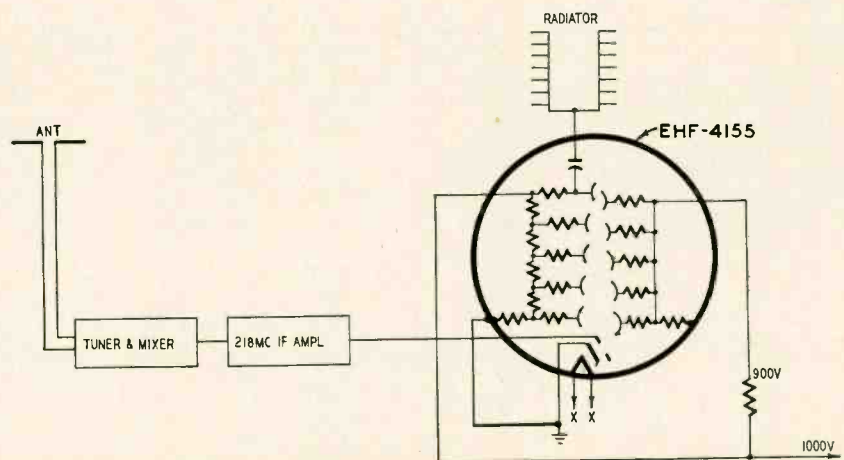

Complete circuit, with internal detail of Transitime voltage multiplier tube.

*Institute Radiation Engineers

The receiver is based on a modified commercial FM set.

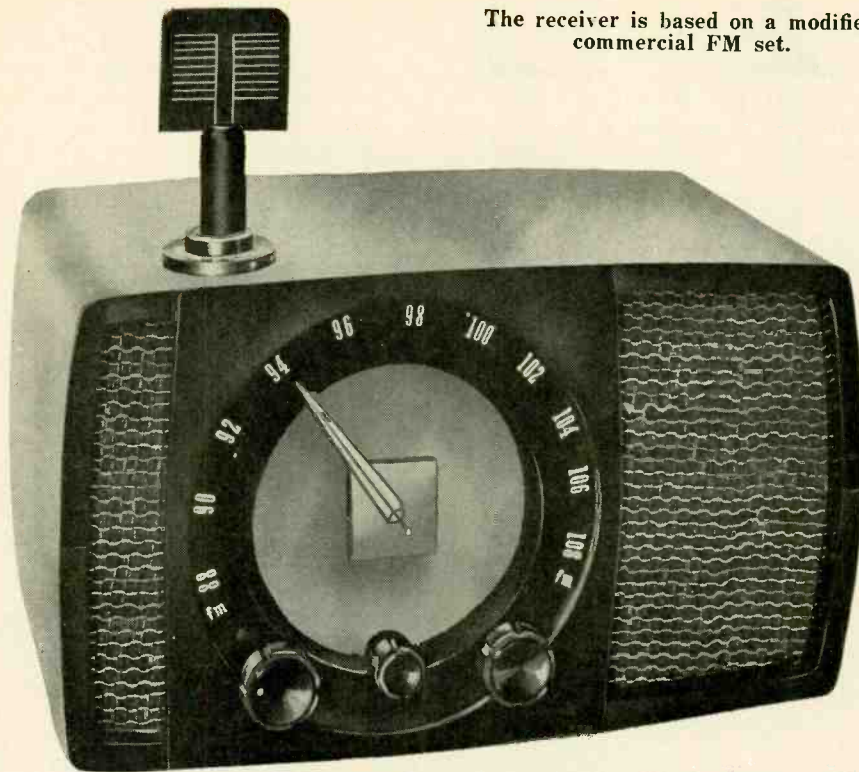

tric currents—radio waves. These we now send into space from our transmitter aerials at frequencies from 550 kilocycles to 108 megacycles (for FM).

"In our homes, the aerials of our receivers intercept these radio waves; we retransform them down into audio currents and feed these into loudspeakers—and we *finally* hear the music or sounds in our ears. About as intelligent and roundabout an idea as scratching your left cheek with your right foot!

"Why do we need audio currents at all? Yes, I know—you will tell me that we have no suitable organ to intercept and *hear* radio waves. I know that too, but listen:

"We know that the human brain is an electric generator. Scientists have proven this with the *electroencephalograph* that records the output of the brain, which in turn generates electrical current day in and out. But just as an electric generator can be reversed and become a motor, so the animal brain can also be reversed under certain conditions and become a receiver, i.e., a motor, for electromagnetic waves. *Example:* carrier pigeons, when flying near a powerful broadcast station, can no longer orient themselves. They become confused by the action of the radio waves on their brains. All this is well authenticated.

"Evidently, there IS a way to reach the brain *directly* with radio or similar waves, so let's hop to it and eliminate the archaic sound waves of our pre-historic past—at least as far as our almost useless ears are concerned. Let's be modern and really enjoy music that IS music, from 16 to 32,768 cycles—THE ENTIRE RANGE, not just a pitiful 25% of it! And that, Fips, will be your job for the next three months! Get busy. I want results, less any and all alibis!"

With that the boss pushed one of his Havanas into the middle of my face and simultaneously whacked me on the back and out of his office.

Let's draw a merciful three months' curtain over the intervening laboratory scenery.

After some research, I decided to *eliminate all audio circuits* from a specially designed FM radio receiver, and instead of stepping the radio-frequency output *down*, I stepped it UP.

I had reasons to believe that, if there was a solution, it would be found in the little-known and almost completely unexplored region of the electromagnetic spectrum which is found between the radio and television region and the infra-red frequencies. See chart, next column. My figures showed that pigeon brains probably responded to the broadcast waves in a peculiar manner *through their wings, which acted as effective aerials while in flight*. The beating wings modulated, or rather polarized, the radio-frequency waves emanating from the broadcast station. But it was also known that the pigeons were never affected, say, a mile away from the station. Why?

TYPE OF VIBRATION OR RADIATION	NUMBER OF VIBRATIONS (CYCLES) PER SECOND
Electric and sound	
Subsonic	Under 20
Power distribution and transmission	25 to 500
Audio (sound)	20 to 20,000
Ultrasonic (sound)	20,000 to indefinite
Radio	
Fixed, maritime, mobile, radio-navigation	10,000 to 150,000
Broadcasting, sea and air radio-navigation, mobile, safety	150,000 to 535,000
Broadcasting	535,000 to 1,605,000
Industrial, safety, government, international broadcast, mobile, fixed, scientific, medical	1,605,000 to 54 million
Broadcasting (television)	54 to 72 million
Mobile	72 to 76 million
Broadcasting (television)	76 to 88 million
Broadcasting (FM)	88 to 108 million
Air radio-navigation, mobile	108 to 132 million
Government, amateur, fixed, mobile, safety	132 to 174 million
Broadcasting (television)	174 to 216 million
Fixed, mobile, government, amateur, radio-navigation	216 to 460 million
Citizens radio band	460 to 470 million
Broadcasting (u.h.f. TV)	470 to 890 million
Broadcasting, government, radio-navigation, amateur, fixed, mobile	890 to 1,300 million
Fixed, mobile, radio-navigation, amateur, industrial, scientific, commercial communications, etc.	1,300 to 30,000 million
Experimental and amateur	30,000 to 100,000 million
Millimeter waves, quasi-radio frequencies	100,000 to 1,000,000 million
Infra-red, light, X-rays	
Quasi-infra-red	1,000,000 to 10,000,000 million
Infra-red, radiant heat	10,000,000 to 400,000,000 million
Visible light	400,000,000 to 800,000,000 million
Ultra-violet light	800,000,000 to 50,000,000,000 million
Soft X-rays	50,000,000,000 to 100,000,000,000 million
Industrial X-rays	100,000,000,000 to 10,000,000,000,000 million
Hard X-rays, industrial X-rays	10,000,000,000,000 to 100,000,000,000,000 million
X-rays, unexplored region	Above 100,000,000,000,000,000

AUDIO—HIGH FIDELITY

The simple answer: HEAT! Close to the station, the energy (watt) output runs very high. So here we have a high-frequency radio effect PLUS a simultaneous infra-red-frequency effect. *The two added together affect the animal brain, as predicted in my calculations.*

Intensive tests soon confirmed the fact that at a critical point somewhat above 1,000,000 megacycles, there was a narrow band where sounds of all types could be "heard," NOT through the auditory nerve, but DIRECTLY through the consciousness of the brain.

I quickly proved this by bringing music to people who had been born deaf and those whose auditory nerves had been destroyed.

How does this silent music "sound"? It is quite indescribable! How would you describe a scent? The music and other sounds have a rather eerie effect—something quite ethereal—that fills and permeates your entire consciousness. And the experience of listening to sounds above 30,000 cycles is magical and breathtaking—at times it makes you actually shiver with delight when the music ascends into the fantastically high reaches never before sensed by mortal man. Such music, so far, is indeed rare—obtainable from only the best FM stations.

Truly, humanity will experience new and astounding thrills and pleasures, once silent sound is widely introduced to the world.

For important patent reasons, I naturally cannot divulge all the technical data of silent sound at this time. For this reason I will give only an outline of the new development.

The circuit diagram, page 36, shows the elements of the silent sound, to be known as S.S. system. It will be noted that it is an FM receiver which has no audio but an *extra-high-radio-frequency amplifier*—e.h.f. Instead of the usual speaker, the S.S. set has a special e.h.f. radiator, a peculiar type of antenna which radiates frequencies above 1,000,000 (one million) megacycles. This radiator is shown in the photograph, page 37. It is only 1 inch high.

The problem is, of course, how to produce the extra high frequencies. I solved it first by employing an Infra-dyne (recently called Summadyne) circuit, a superheterodyne which uses the sum instead of the difference frequency of the received signal and local oscillator. Thus the signal supplied to the e.h.f. amplifier was at 218 mc instead of the standard 10.7-mc i.f.

The signals were applied to the control element of the Transitime tube, a voltage and frequency multiplier that operates on the *transit-time* principle. It is well known that microwaves can be amplified by ordinary tubes if the frequency is so chosen that the *transit time* of the electrons results in their being in phase at each of the tube elements. The 10 anodes of the Transitime tube are arranged at evenly *decreasing* distances from each other, to

take advantage of this principle.

The distance between the first two plates is selected to favor a low—and therefore strong—harmonic of the input signal. The plates are too close together to accommodate the fundamental and a few of the lowest harmonics, which are suppressed as a waveguide suppresses a wave below its cutoff frequency. The amplification at the pass frequency is 50 to 100, depending on voltage, and is due to *secondary emission* of electrons from the plate. Higher harmonics are passed in the same proportional strength as in the unamplified signal.

The distance between the second and third plates accepts a harmonic of the frequency amplified by the first two, and so on, each path between plates suppressing the former fundamental and producing a new and higher fundamental and harmonics. Since harmonics are always much weaker than the fundamental, the greater part of the tube's amplification capabilities are used restoring that difference, but there is a continual gain of amplitude through the tube.

The 1,000,000-mc signal at the last plate is radiated by a system tuned to the correct frequency by means of printed-circuit techniques. The antenna is a thin conductive layer, the *thickness* of which is a half-wave at 1,000,000 mc. The shape and other dimensions of the antenna are not important and were chosen in this case to make the antenna slightly directional, increasing the forward range.

How does the human brain receive these high frequencies? Through a distinctive type of headband illustrated at top of page 36. The headband is made of a special high insulating new plastic called *Metavynol*. It is thus not af-

ected by the perspiration of the forehead. Note that the receiving antenna is in the center. *It is appliquéd—a printed circuit.* Two metal contact discs go over the temples; the discs in turn are connected by printed circuit with the tiny antenna. The contact discs are made of a recently invented highly porous metalloid foam. It heats up to about 101° F. under the impact of the e.h.f. waves. *These waves are now conducted to the sound perception center in the interior of the brain, making S.S. reception possible.*

It is in the metalloid foam that the transmissions are changed from FM to AM. The center frequency of the e.h.f. waves is the resonant frequency of the molecules of this substance. Any deviation from the center frequency due to modulation affects the amplitude of their vibration and hence the strength of the signal sent to the brain. Incidentally, the signal is transmitted along the headband to the templets by the principle of the G-line, the waves being imprisoned in the thickness of the printed line and reflected back by each of the boundary surfaces.

The S.S. radio set is tuned just as is any regulation set, through a station selector; thus one can select any desired channel. Good reception usually can be effected up to about 30 to 40 feet from the radio set antenna. *The e.h.f. waves are stopped by walls or ceilings, thus neighboring sets cannot interfere with each other.*

Naturally people in the room not wearing the special headbands do not hear a sound, a special blessing of the S.S. system.

Further details must be withheld until next year in our issue to be published

APRIL 1

EDUCATIONAL HOBBY KIT

With the aid of a new *Electronics Hobby Kit* now on the market, it won't be long before children interested in this field will be performing experiments that will provide most of the answers they seek. The kit was prepared by RCA in collaboration with the Encyclopaedia Britannica and the Museum of Science and Industry.

Working with the kit, youngsters start with experiments in static electricity and batteries. Additional experiments involve making an electromagnet, experimenting with capacitors, understanding the function of electronic tubes, learning the Morse code. Advanced experi-



ments include the construction of a simple low-powered radio transmitter and a one- or two-tube radio receiver.

The kit, designed for ages 8 to 18, is being distributed by Central Scientific Co., Chicago, and retails at \$29.95.

FOR GOLDEN EARS ONLY

*The Hartley 215 speaker and the
Baffle; Altec 303C tuner; new
records review*

By MONITOR

ONE of the more remarkable personalities in the high fidelity field is Mr. H. A. Hartley. And my tests on his 215 speakers—which are very unconventional in design—and *Baffle* indicate that his products are equally remarkable. Mr. Hartley makes the startling claim that the 215's are nonresonant within the audio range. So far as I can determine this claim is true! I could find no resonance anywhere in the range above 20 cycles, the bottom of my generator.

Mr. Hartley also claims a response of from 20 to 20,000 cycles. Since I do not have an anechoic chamber and a precisely calibrated mike, my tests cannot be considered conclusive. However, for what it's worth I report that in the *Baffle* the pair of 215 speakers produced an excellent response down to 40 cycles and continued to give audible reproduction of fundamental (with very little doubling) for some distance below 30 cycles. I consider it very likely that in a suitable horn or larger infinite baffle, the response would continue down to 20 cycles. On the high end the response goes easily to 17,000 cycles and may extend beyond this with some slope to 20,000.

I have pointed out repeatedly that personal taste and preference must be taken into account in listening tests for loudspeakers. Like Mr. Hartley, I have always preferred nonresonant speaker systems and have gone to a great deal of trouble to approximate nonresonance in my own. I am, therefore, thoroughly accustomed to the sound of such a system and, naturally, prefer it to resonant or even horn systems.

In any case, I like the sound produced by the 215 speakers very much indeed. The transient response is remarkable; the whole range is covered as smoothly as a piece of chrome-plated metal with light oil. Especially notable is the fact that although the treble response at the extreme end is flatter than with most speaker systems, the reproduction is not at all shrill. The bass is outstand-

ingly natural and the bass definition exceptional. People accustomed to the more accentuated bass of resonant enclosures and speakers will no doubt feel at first hearing that it is short on bass. I consider the combination at least as good as anything I've heard (short of theatre type installations). Achieving all this in an enclosure only 30 inches high, 18 inches wide and 17 inches deep is a noteworthy achievement.

The *Baffle* is by no means as funny as its name. In fact, for my money, the principle is nothing short of a stroke of genius. Mr. Hartley's problem was to provide in very compact form an infinite baffle free of internal resonance. To provide infinite baffling the rear wave has to be suppressed or prevented from reaching the front wave and producing out-of-phase cancellation at low frequencies. But when one uses a small box to accomplish this, the stiffness of the enclosed air produces resonance at some point between 20 and 200 cycles, depending on the size of the box.

Mr. Hartley's solution is so simple that at first it reduces one to speechlessness. Instead of using a solid material for the back, Mr. Hartley uses some sort of loosely stretched sound-absorbing burlap and fiber material nearly one inch thick. This provides a very loose back which prevents compacting within the enclosure and therefore avoids resonance. In addition, the enclosure has seven layers of felt, each separated by about 2 inches and forming an acoustic filter that absorbs almost all the rear wave. Thus, only a small fraction escapes to meet the front wave and cancel it. In this way he achieves both infinite baffling and nonresonance with incredible simplicity and cheapness. The principle is widely applicable and experimenters might well try using it.

There is a price to pay for everything and the Hartley system does not achieve its fine performance without some sacrifice, namely somewhat lower efficiency. This is because the rear

wave is wasted instead of being used to reinforce the front wave as in reflex and horn-loaded speakers, and neither the speaker nor enclosure is resonant. In the two-speaker combination this loss is almost made up by the increased efficiency due to mutual coupling of the two radiators; in the four-speaker combination the efficiency is about average. More bass boost and power output will be needed for the simpler Hartley combinations, but the loss of efficiency does not exceed 6 db in the case of the single speaker and is far less in the larger combinations. No modern high-fidelity amplifier should have any trouble supplying plenty of undistorted drive for any home-listening purpose.

I obtained permission to remove the speakers and their mounting board and to install the combination in my wall-type infinite baffle. As I suspected the two Hartley speakers produce a really superb sound in a wall mount. The bass extends to 20 cycles, though the slope is fairly severe below 30 cycles. Given a good bass boost (and the Hartleys can take it smoothly) the quality is extremely real. I would judge that a single Hartley in a closet would be very pleasing for small-apartment use, and a battery of four ought to provide really spectacular sound.

Altec 303C tuner

The latest in the series of Altec Lansing tuners is a more sensitive refinement on a now well proven design. It uses two independent tuners for AM and FM reception. The AM portion is entirely adequate though it does not pretend to offer extreme sensitivity. The i.f. bandwidth provides an excellent compromise between adequate selectivity and good audio quality. The tone quality is good for AM; interchannel beat-note and monkey-chatter interference is low enough not to be annoying. It will provide adequate reception in most locations with the simplest antenna—even the FM antenna. Adding an outdoor antenna can extend the

Side view of the Hartley 215 speaker. Unit is nonresonant through audio range.

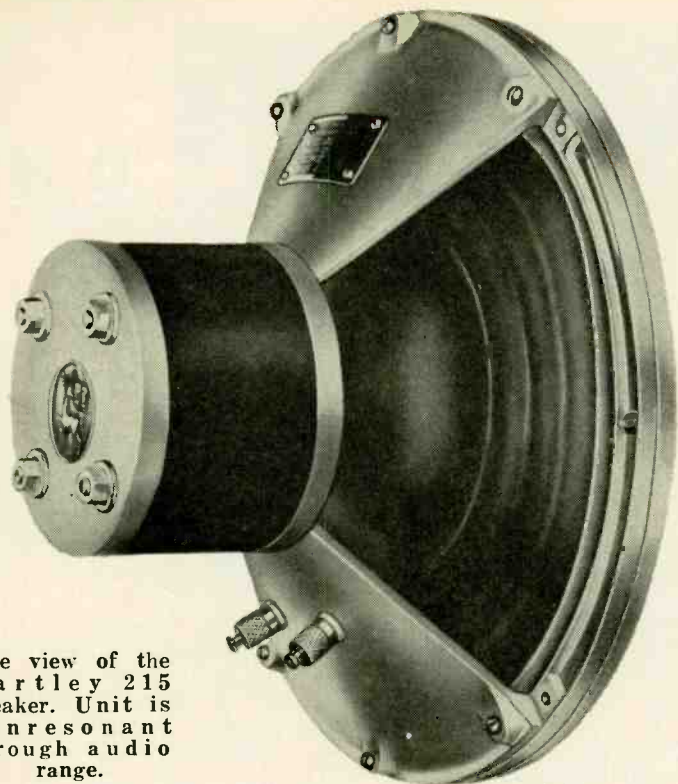

range greatly where more sensitivity is necessary.

The FM portion is excellent in all respects. A cascode r.f. stage, two i.f. stages, one limiter and a ratio detector result in very good sensitivity—about 4 microvolts for 40 db of quieting. In my location this was sufficient to provide noise-free reception on all but one of the available high-fidelity stations, including two some 140 airline miles distant. A third station in the same city was still somewhat in the noise. The sensitivity would be higher if a.v.c.

were not applied to the r.f. and first i.f. stage. However, the a.v.c. is good insurance against the phase distortion which often occurs through overloading on strong local stations. The passband appears to be close to 200 kc at 6 db down. The distortion is very pleasantly low.

The a.f.c. can be disabled by a function selector switch; however, it is easy to tune a weak station adjacent to a strong one with the a.f.c. on. An "eye" indicator permits accurate tuning and the receiver is as easy to tune on FM and AM.

The audio control portion is completely satisfactory. There are two jacks on the back for additional inputs—a magnetic pickup and a higher-level input such as a tape recorder or a crystal or ceramic pickup. The input in use is indicated on the dial. The audio channel is fairly flat from 20 to 20,000 cycles (Fig. 1). The slight rise in the bass is probably due to the fact that the bass control was not precisely neutral. This curve was taken with the generator applied to the spare (high-level) input channel and does not include the phono preamp. The IM distortion is below 2% (Fig. 2) for all levels of out-

put less than 3 volts. Much higher output is available at higher distortion levels, but 2 volts will be sufficient with most amplifiers to obtain maximum output.

Separate bass and treble controls provide both boost and attenuation. The curves of Fig. 3, supplied by the manufacturer, indicate the range of control honestly and accurately. The treble boost is not great. This may be a disappointment to treble hounds but seems to me a wise precaution against misuse and consequent headaches, particularly since the response of the entire tuner is flat in the treble and requires no further treble boosting.

The record equalization follows previous Altec practice and is rather unusual. The phono switch offers three choices, AES equalization; crossover of 250 cycles but no treble equalization and 800-cycle crossover and no treble equalization. Treble equalization for the latter two positions can be obtained by manipulating the treble control. Since most records with 200- or 800-cycle crossovers are recorded flat in the treble, this is very satisfactory. The four curves in Fig. 4 show the response I obtained with the four American curves recorded on a Dubbings D-101. These were made with the tone controls in the neutral or flat position and the phono switch turned to AES equalization. It is evident that by and large the AES equalizer produces acceptable results from all the recording curves and does very well with the new ORTHO-RIAA curve. The bass and treble controls can be used to shape the phono response further.

The 303C is well built, handsome and reflects quality design throughout. It is primarily designed for use in custom-built home music systems where high-quality radio reception and phonograph reproduction are prime requisites. A front-view photograph of the 303C AM-FM tuner appears at the top of the opposite page.

New Records

Note: Records are 12-inch LP and play back with RIAA curve unless otherwise indicated.

- BARBER: *Adagio for Strings*
- DIAMOND: *Rounds*
- COPLAND: *Quiet City*
- CRESTON: *Two Choric Dances*
Capitol P-8245

This particular Capitol disc, I am sorry to say, is not one of their best. The definition is inferior throughout and the sound is dead, though this is partly a matter of miking. *Quiet City* and *Adagio for Strings* are duplicated in recent Mercury offerings and personally I found the Mercurys cleaner with better bass, better definition and more presence. Not that these are bad—by no means—they simply aren't up to the high standards achieved by others and Capitol previously.

All this music is worth listening to and, with a little patience, easy to listen to. The *Two Choric Dances* seem to me the most interesting in instrumentation. They would be excellent for indicating the contrast between the various types of basses, but unfortunately the recording itself does not show this too well.

The *Rounds* shows that Capitol can do better and this is the best of the lot. The highs are

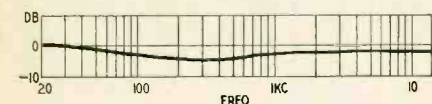

Fig. 1—Response of the audio channel.

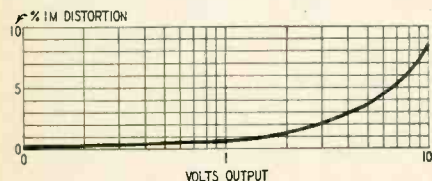

Fig. 2—IM distortion characteristic.

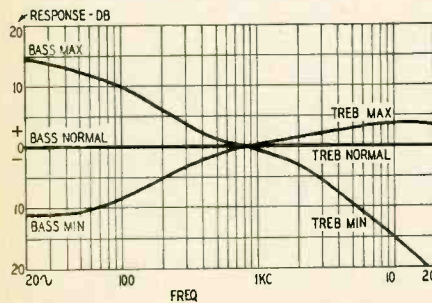

Fig. 3—The bass and treble response.

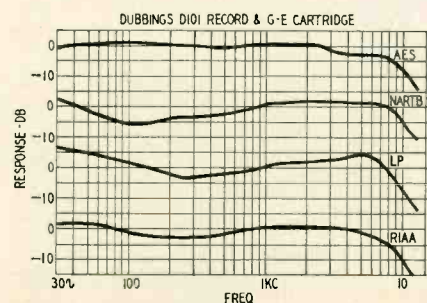

Fig. 4—AES equalizer response curve.

bright and clean, the bass growls more, the fiddling strings have a nice sharp bite.

Good enough to enjoy and appreciate the music fully; but not for test, demonstration or show-off.

HINDEMITH: *Symphonic Metamorphoses on Themes by Carl Maria von Weber*

SCHOENBERG: *5 Pieces for Orchestra, Op. 16.*

Mercury 50024

This is definitely not for the layman or even the average music lover: it is for those who really like modern music. Don't let that part of the title about themes from von Weber fool you. Von Weber himself could listen for a month of Sundays without being aware that he contributed the themes, which, anyhow, are from obscure piano pieces, not the familiar overtures. Having made these reservations, let me add that those who can take it at all will find this music stimulating and with a fine sound. Freer of artificial hi-fi effects than some of Mercury's more spectacular discs, clean and with a remarkably fine orchestral tone. The Scherzo of the Hindemith has excellent clean percussives of rather individual tone. The crescendos are exceptionally clean. There are very fine brasses and winds, and the sound of Orchestra Hall comes through faithfully.

The Schoenberg is remarkable for its sharp, snarling, snorting, growling brasses and winds—I know of no brasses like these. The whole work is excellent test material for definition, partly because of the 12-tone scale, but also because of the rather unique polyphony. There are some very subtle tonal nuances, even in the percussive sections. The opening of the second movement has some vibratos similar to those produced by multiple bell ringing. Later there is a very percussive bass, very deep. The whole thing is excellent for distortion testing because the exquisite dissonances (if you insist on calling them that) would be unbearable if compounded by distortion, especially in the finale. Unless the family and neighbors are connoisseurs of music this is certain to bring violent complaints if you play it loud enough to get the full benefit of the music. But that's your problem. I live in the middle of the woods and my wife has the faculty of mentally plugging her ears.

WALTON: *Belshazzar's Feast*
London Philharmonic Promenade Orchestra

London Philharmonic Choir
Sir Adrian Boult conducting.
Westminster WL 5248

I have never cared much for cantatas, even Bach's, though I can listen to anything else he wrote all day long. But this disc may convert me. It is a moving work, displaying skillful use of voices and instruments to produce a highly emotional effect. The recording is possibly the most realistic treatment of mixed voices and orchestra in the catalogs.

The definition of both voices and instruments is phenomenal. The sibilants and other vocalizing transients are brilliantly reproduced. On occasions you can hear, not only the soloist, but the entire chorus drawing in its collective breath. The work employs an extraordinary number of instruments and, if you listen carefully, you can pick them out from the crowd. The percussives are notable and the bass is both very low and terrific in spots. Unquestionably one of the best recordings so far made. Even if you don't care for choral music, you'll find this useful for demonstration.

RIMSKY-KORSAKOV: *Scheherazade*
Argeo Quadri conducting the Orchestra of the Vienna State Opera.
Westminster WL 5234

RIMSKY-KORSAKOV: *Capriccio Espagnol*

RAVEL: *Bolero*
Paul Paray conducting the Detroit Symphony

Mercury MG 50020

The trouble with most good hi-fi test and demonstration records is that, more often than not,



The Altec 303C tuner, designed primarily for use in custombuilt home music systems.

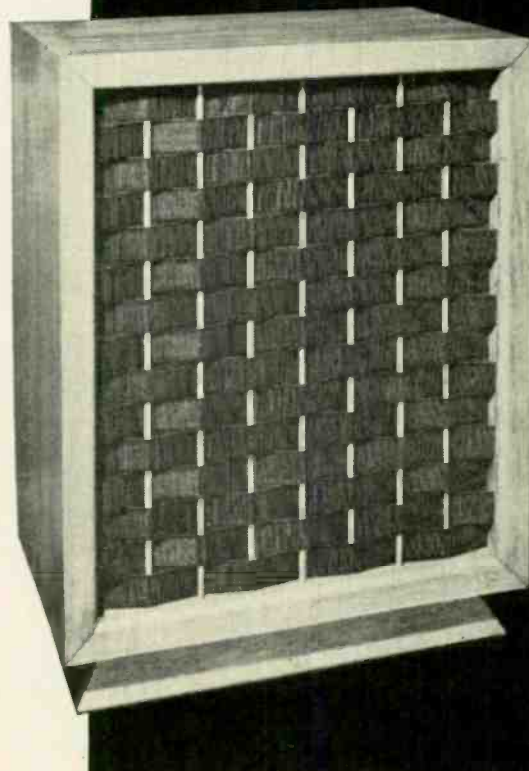

The "Grand" Baffle for two, three or four Hartley non-resonant speakers.

the music is in the modern idiom which the ordinary layman and many music lovers find rather hard to take. It's pretty silly to demonstrate a system with material the listener doesn't like, but I concede I've been gully of it myself. Here then are some discs which will make a hi-fi system sound stunning and still provide tuneful, unheadachy listening—well calculated in all respects to win admiring comments.

The Mercury *Bolero* is very clean and sharply defined. If you know your instruments, you should have no trouble listing the 18 choruses and the instruments involved in each one. The doubling of two dissimilar instruments in unison, but a couple of octaves apart, is clearly audible in the ninth, tenth and twelfth.

The *Capriccio* has a tremendous opening, excellent definition in peaks, a tone which is not only realistic but lovely throughout, sharp snare drums and a nice big, low-toned bass drum. The

instrumental coloring, so distinctive of this music, comes through very nicely.

Westminster's *Scheherazade* is also stunning. The fine recording reveals every facet of the music. Even those who have heard it too often to be really fond of it should find it interesting. There is a fine double bass in the opening; the fingering on the solo violin is occasionally audible and the percussive highs in the third movement are as realistic as the dropping by a waiter of a trayful of cutlery. The resonance of the famous Konzerthaus comes through well; the fiddles in the fourth are very sharp; the drums in the final movement are really frightening—like Death itself knocking impatiently at the door or thunder shaking the foundations of the house.

Both these records are examples of the best of today's techniques and evidence how small is the gap between us and complete realism. END

Junior Record Player-Amplifier



The junior record player-amplifier.

Phonograph features quick warmup, automatic shutoff

By NORMAN L. CHALFIN

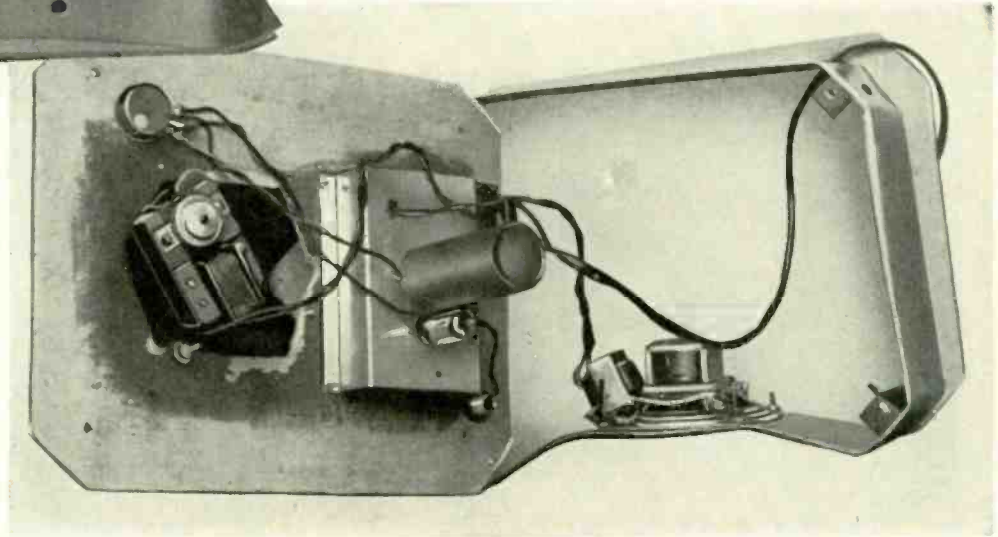

Internal view shows parts mounted.

KIDS love to play records. Even the little 1-year-old reaches for the turntable or the arm to try to operate the record player. But for him most machines are too complex. There's the on-off switch, the volume control, the arm and finally the operation of shutting the machine off after the record is played or turning off the motor between records. On most children's record players the volume control and switch are one. Turning off the record shuts off all power and delays the start of the next record while the set warms up.

I've known youngsters to leave a record player on over night because the shut-off operation was forgotten. Others have cried because, when the record was started, there was no sound during the warmup delay—a half minute or more. This is nearly half of the playing time of some children's records. It was to eliminate these problems that this phonograph* was built.

The only operation necessary to set both the motor and amplifier in operation instantly is to lift the arm. By the time it is moved from the arm rest to the turntable the amplifier is warmed up. The motor starts even faster.

The circuit (Fig. 1) contains a one-

tube power amplifier (battery type), a selenium rectifier and a Microswitch. The selenium rectifier provides plate and filament power for the 3V4 pentode amplifier. A dropping resistor from B plus to one side of the filament and a resistor from the other side of the filament to B minus make up a 50-ma bleeder system for filament current. The resistor in the B minus side provides grid bias.

A Microswitch built into the chassis assembly or attached to the underside of the top of the cabinet, directly beneath the arm rest, is the on-off control for motor and amplifier. It is normally closed; the weight of the pickup arm opens it. A rod through the pickup rest acts as a piston to depress the leaf of the switch. This opens the circuit as long as the pickup remains on the rest. The moment the arm is lifted, the pressure is released and the switch closes the circuits to both the amplifier and the turntable motor. There is no delay in the operation of selenium rectifiers, and it takes only a second or two until the filament of the 3V4 is heated.

No particular wiring precaution is necessary. Mount the volume control on the motor board (see photos). The output transformer is mounted on the speaker. The speaker and transformer

are mounted on the front of the plastic wraparound. The important feature of this unit is the switch circuit and its operation through the pickup rest (Fig. 2). All other constructional details are arbitrary and any convenient cabinet arrangement will do.

A finer circuit that permits use of low-output pickups for three-speed operation is shown in Fig. 3. A three-speed motor is, of course, required. The leads between pickup, volume control

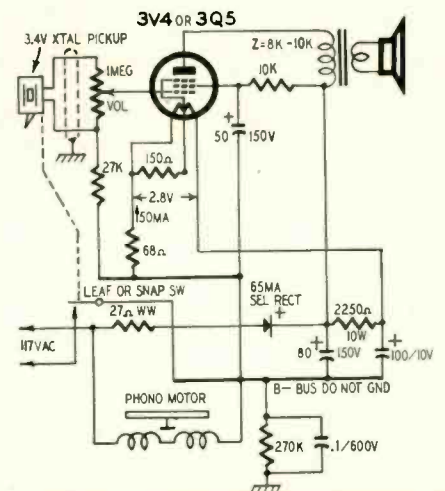

Fig. 1—The one-tube phono amplifier.

*U. S. Pat. No. 2,680,786

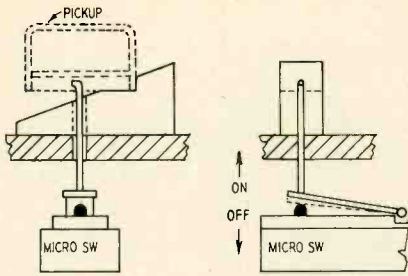

Fig. 2 (Left)—Details of the pickup rest.

and amplifier input should be shielded because the low level and higher gain will make the circuits more sensitive to hum pickup. The tube lineup for the three-speed circuit is a 1U5 or 1L4 pre-amplifier and 3V4 power output stage.

(This record player uses a transformerless type power supply with one side of the line connected directly to a common B minus bus, so all precautions to minimize shock hazard must be taken.

The amplifier must be fully enclosed within a nonmetallic cabinet or case with all protruding screws or bolts which touch the chassis carefully countersunk and insulated. Note the author's cabinet construction. Be sure that the push rod in the pickup rest is made of nonconducting material. The pickup arm should be plastic and the

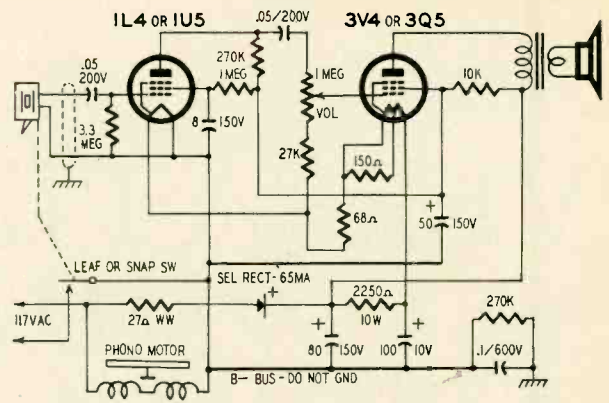

Fig. 3 (Right)—Schematic diagram of phono amplifier for low-output cartridge.

Parts for 1-tube amplifier

Resistors: 1—27 ohms, 1/2 watt, wirewound; 1—68 ohms, 1—150 ohms, 1—10,000 ohms, 1—27,000 ohms, 1—250,000 ohms, 1/2 watt; 1—2,250 ohms, wirewound, 10 watts; 1—1-megohm potentiometer.
 Capacitors: 1—0.25 µf, paper; 1—50 µf, 1—80 µf, 150 volts, electrolytics; 1—100 µf, 10 volts, electrolytic.
 Miscellaneous: 1—pickup arm (nonconductive); 1—crystal cartridge; 1—3V4 or 3Q5; 1—Microswitch, leaf type (normally closed; open when leaf is depressed); 1—selenium rectifier, 65 ma; 1—PM speaker, 3.2-ohm voice coil; 1—output transformer, primary impedance: 10,000 ohms, secondary im-

pedance: 3.2 ohms; 1—78-r.p.m. motor and turntable; 1—chassis; 1—board for mounting chassis, motor, pickup arm and volume control; 1—rod for pickup rest (nonconductive); 1—cabinet; 1—power cord.

Parts for 2-tube amplifier

All parts previously listed (less motor, pickup arm and cartridge) plus the following: 1—250,000-ohm resistor; 1—1 megohm, 1/2 watt resistor; 1—3-megohm, 1/2-watt resistor; 2—.05-µf, 200-volt capacitors; 1—8-µf, 150-volt electrolytic capacitor; 1—1L4 or 1U5; 1—3-speed motor, pickup arm and cartridge.

cable between the cartridge and amplifier should be two-conductor type with an insulated shield. All ventilating holes should be adequately screened

against tiny prying fingers. With these precautions, the phonograph is perfectly safe for even the smallest child. —Editor) END

HIGH-FIDELITY DICTIONARY

By ED BUKSTEIN

Part III

Overcutting

The result of excessively wide excursion of a cutting stylus, causing it to break through to an adjacent groove.

Overhead cutter

A cutting head assembly suspended above the disc as distinguished from a cutter mounted in the end of a swing-arm mechanism. The overhead cutter is mounted on a threaded shaft known as a lead screw, rotation of which moves the cutter from the edge of the disc toward the center.

Pad

A configuration of resistors designed to attenuate the signal without introducing impedance mismatch. (See Attenuator.)

Port

An opening in a loudspeaker enclosure other than the one behind which the loudspeaker is mounted. (See Reflex baffle.)

Preamplifier

An additional amplifier preceding the main amplifier. The preamplifier is generally used to build up the signal from a microphone or pickup to a value sufficient to drive the main amplifier. The preamplifier is usually, but not always, built on a separate chassis and may have its own power supply. The program selector (AM, FM, television,

phono, etc.), equalizer, loudness control and bass and treble tone controls are often located in the preamplifier.

Pre-emphasis

The process and result of boosting the high frequencies during recording to increase the signal-to-noise ratio. This is necessary because the lateral swing of the cutting stylus becomes progressively smaller at the higher frequencies. In the playback equipment, the high frequencies must be de-emphasized to restore them to their correct relative level. Pre-emphasis and de-emphasis are also used in FM radio systems to improve the signal-to-noise ratio.

Presence

That quality of a sound-reproducing system that creates the illusion of listening to the original sound rather than to its reproduction.

Printing

The transfer of magnetic patterns from one layer of tape or wire to an adjacent layer on the spool.

Record noise

Noise voltages produced as the stylus passes over the granular surface of the record. Record noise is also known as *record scratch* or *surface scratch*.

Reflex baffle

(See Bass reflex enclosure.)

Reluctance

That property of a material which opposes the establishment of a magnetic field. Reluctance in a magnetic circuit corresponds to resistance in an electrical circuit.

Rumble

Low-frequency sounds introduced during recording (or during playback) by vibrations of the turntable or motor.

Shot effect

The random emission of electrons from the cathode of a tube. Since the number of electrons emitted per unit of time is not constant, the plate current is modulated by random fluctuations. These fluctuations increase the noise level.

Stereophonic

A sound-reproducing system designed to preserve some of the realism of the original sound by overcoming the *point source* characteristics of the loudspeaker.

The number of loudspeakers used in the reproducing system is equal to the number of microphones, and the physical arrangement of these loudspeakers corresponds to the arrangement of the microphones. In this way, each loudspeaker reproduces the sound the listener would have heard had he been located at the position of the corresponding microphone. TO BE CONTINUED

Adding VERSATILITY to MASTER INTERCOM UNITS

By JOHN T. FRYE

RECENTLY a contractor came to me with a problem, the solution of which may interest other service technicians. To understand the problem fully, the following facts must be known:

Several departments in the contractor's establishment were connected by Talk-A-Phone model KS-60 units in an all-master setup. A skeleton diagram of the input and output circuits of one of these units is shown in Fig. 1. In opera-

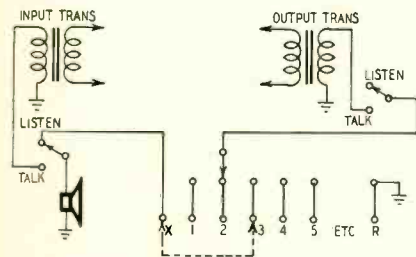

Fig. 1—Basic input and output circuits.

tion, similarly numbered terminals of all units have common connections, as do all R terminals. On the junction block of each station a jumper is run between the terminal number assigned that station and the X terminal. (Station No. 3 is shown in the diagram.)

The TALK-LISTEN switch is in its LISTEN position; the speaker of the unit is connected between terminals X and R. When this switch is depressed to the TALK position, the speaker is connected across the input transformer for use as a microphone, and the output of the amplifier appears between the numbered terminal to which the station selector is set and the R terminal. The amplifier is used only for talking. When one unit calls another, the amplifier of the station called must be turned on and warmed up, its selector switch must be

set to the number of the station calling, and its TALK-LISTEN switch must be held in the TALK position to answer the call. Each operator must manipulate his TALK-LISTEN switch throughout the conversation.

The contractor wanted to retain the features of this all-master system. But in addition he wanted to use one unit as a control station from which he could call any other station and get an immediate answer from an operator at that station. All this without the operator's having to do anything but talk from wherever he might be standing in the room. Furthermore, the contractor wanted to add simple slave stations, in the form of PM speakers, at locations where it would not be necessary to originate calls but where the control station could call and get an answer.

At first this seemed like a large order; but after considerable diagram sketching, a simple solution was found. It was only necessary to mount a d.p.d.t. switch in a hole on the side of the cabinet and connect it into the intercom unit as shown in Fig. 2.

When this switch is in the MASTER position, the circuit is exactly the same

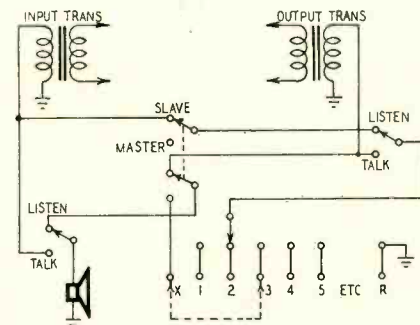

Fig. 2—Schematic of the revised circuit—MASTER-SLAVE switch is added.

as in Fig. 1 and the unit works in the all-master system just as always. The switch is normally left in this position. However, when this switch is thrown to SLAVE, the speaker of the unit to which the station selector is adjusted is connected across the input transformer in the LISTEN position and the control station's own speaker is across the amplifier output. In the TALK position, the control-station speaker becomes a microphone, and the output of the amplifier goes out through the numbered terminal to which the station selector is set and the R terminal to the speaker of the remote unit. In short, throwing the switch on the control station to SLAVE converts all other master units into slave stations.

An advantage of this is that stations called by the control station do not have to be turned on or manipulated in any way to respond. Only the operator of the control station needs to operate a TALK-LISTEN switch. This is especially helpful in calls to a location where the person answering may not be able to leave what he is doing. Extra slave stations can be added to the system for use by the control station simply by running leads from an unused numbered terminal and the R terminal on the nearest junction block to the voice coil of a PM speaker.

A converted master station can be used with a single slave station wired as shown in Fig. 3 so that calls may orig-

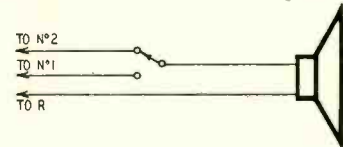
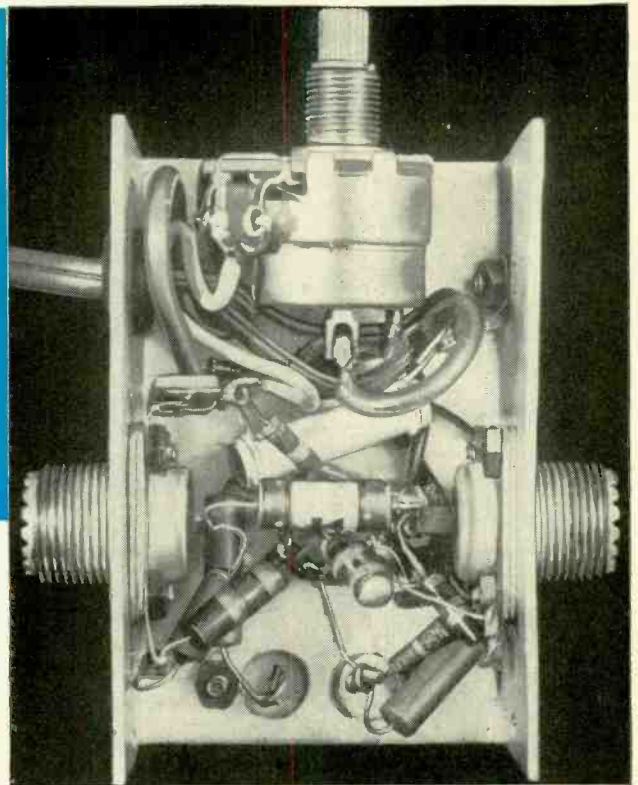

Fig. 3—Slave-unit connections for use with converted master station.

inate from either end as long as the amplifier of the master station is turned on. A s.p.d.t. switch is used, spring-loaded to remain normally in the position shown. The station selector of the control station is normally left in position No. 1, which means nothing will be heard at either end. When the slave-station operator wishes to originate a call, he holds the switch down so that the speaker voice coil is connected into the input of the control station through the SLAVE switch contacts. The control-station operator answers by holding his TALK-LISTEN switch down to talk and letting it is up to listen. If he turns his selector switch on position No. 2, it is not necessary for the slave-station operator to hold his switch down during the conversation.

When a control station is working with a single slave station or is working in an all-master system, the control-station operator can listen in on any station in the system simply by throwing the MASTER-SLAVE switch to SLAVE and by setting the station selector to the number of that station. Depending upon the circumstances, this may or may not be an advantage! END

SIDEBAND MODULATOR for MARKER GENERATOR



Left—Top view of the sideband modulator.
Right—The sideband modulator underchassis.

By BRUCE A. MORRISSETTE

TV front ends and i.f. amplifiers are generally aligned with a setup similar to that in Fig. 1. Unless the marker generator can produce multiple pips, the technician is limited to the single marker frequency provided. Adding a simple, compact, self-powered sideband modulator, as shown in Fig. 2, will place additional pips on the response curve. They will be separated from the main marker point by the crystal frequency of the sideband unit.

For the alignment of front ends, a 4.5-mc crystal will place a sideband marker on the response curve at a point indicating the position of the audio carrier, if the marker generator is set at the video carrier frequency (or a submultiple thereof). Fig. 3 shows an idealized front-end response with video and audio carriers

The sideband modulator yields the curve of Fig. 4 for i.f. alignment. Here the marker generator is set at the video i.f. carrier frequency (26.4 mc in this example) and a 1.5-mc crystal is used in the sideband unit. Pips are then produced at the adjacent-channel audio point, at 1.5-mc intervals across the top of the curve (indicating bandwidth) and at the audio i.f. carrier (here, 21.9 mc). If the marker generator is set accurately, all important points on the response curve will be indicated simultaneously.

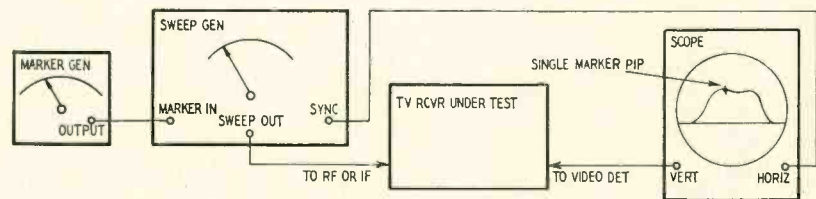

Fig. 1—Conventional alignment setup.

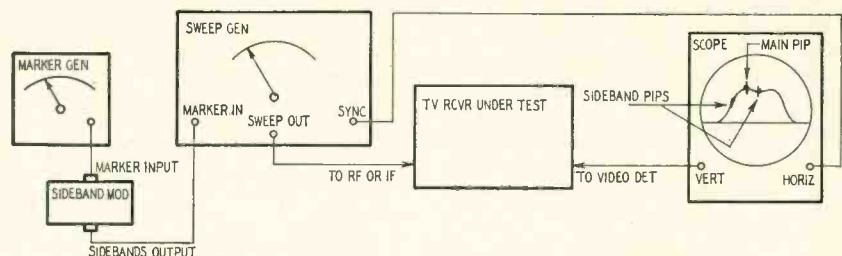

Fig. 2—Using the sideband modulator.

A low-frequency crystal (100 to 250 kc) is used for sound detector alignment and linearity adjustment. Fig. 5 shows 100-kc sideband markers on either side of the discriminator or ratio detector response curve. For intercarrier TV sets, the center frequency of 4.5 mc may be spotted by inserting a 4.5-mc crystal into the sideband modulator unit and turning the marker generator off.

A triode Pierce crystal oscillator with cathode-follower output is capacitively coupled to a wideband crystal diode modulator (Fig. 6). Values are chosen to permit operation over a wide range of crystal frequencies. Connect-

ing the grids and plates of the 6J6 in parallel produces strong oscillation. The 100-ohm resistors at the input and output connectors give wideband characteristics to the 1N34 crystal diode series modulator, so polarized as to strengthen sideband amplitude.

Surprisingly, no d.c. plate supply is required. I noticed no difference in performance when the unit was supplied with rectified and filtered d.c. This not only saves space and the cost of a rectifier and electrolytic filter capacitors, but provides an added feature—the crystal oscillator output is strongly modulated at 60 cycles. Thus, the sideband unit may be used as a crystal calibrator,

TEST INSTRUMENTS

the modulation permitting identification of fundamental and harmonics on standard AM communications receivers.

The modulation does not affect the appearance of the response-curve pips, which have the typical "birdie" agitation of beat-frequency markers. When operating the unit, be sure that the "on" period of the modulator crystal corresponds to that of the sweep generator oscillator if blanking is used. The procedure is simple: If sideband pips appear, the two instruments are in phase. If no sidebands are visible, reversing the a.c. line plug of either unit will restore the pips.

If for any reason the constructor wants to use a d.c. plate supply (Fig. 7), it should be inserted at point X in Fig. 6.

Pip size is controlled by a carbon potentiometer, useful in setting the output level below the point which may cause distortion of the alignment curve. Since the entire device is designed to work at a low level, only a minimum of r.f. signal from the marker generator should be inserted at J1. Alternate manipulation of the marker generator amplitude control and the PIP SIZE control will establish the proper amplitude ratio for best sideband operation.

Construction

Eliminating the d.c. supply permits the entire device to be housed neatly in a 2 x 3 1/4-inch aluminum Minibox. The power transformer, of the miniature type used in TV boosters, was at the time of writing available from Burstein-Applebee in Kansas City (stock No. 19C714). Half-watt resistors and ceramic capacitors help conserve space. I had Amphenol type 83-IR u.h.f. connectors on hand; others may be substituted.

Arrangement of parts, as shown in the photos, is straightforward. If a miniature power transformer is not available or a d.c. plate supply is desired, a larger Minibox can be used. The entire unit may also be built into a marker or sweep generator. The additional heater drain is slight and should not overload the marker or sweep generator transformer. The oscillator plate current can be taken from the d.c. B plus line through a dropping resistor (about 120 volts is required with the PIP SIZE control at maximum).

Additional applications

There are several worth-while additional uses of the sideband modulator:

1. **Crystal calibrator.** A 100-ke, 1,000-ke or other crystal standard can be plugged in and the output taken from connector J2. The 60-cycle modulation permits easy identification of all harmonics, which extend well into the television intermediate frequencies (as high as 50 mc). A signal or marker generator may be calibrated or checked against the crystal standard by connecting it to terminal J1 and viewing successive beats on a high-gain oscilloscope connected to J2.

2. **Response-curve calibrator.** This function should not be confused with the production of sideband markers. Sideband markers are fixed only in relation to the main movable marker pip, and all pips *move together* as the marker generator is tuned across the curve. In response-curve calibration, the pips are *stationary* and represent fixed frequencies across which the marker pip may be moved. To secure this absolute, not relative, calibration of a response curve, the marker generator is not fed through the modulator unit.

With J2 connected to the marker input terminals of the sweep generator (or otherwise coupled to the circuit under test), a crystal with harmonic relationship to the i.f. passband—4.5 mc, for example—is inserted. At the point on the passband corresponding to the appropriate harmonic (the fifth harmonic of 4.5 mc, or 22.5 mc) a stationary pip will appear. This pip may also be used to calibrate the marker generator, fed into the circuit under test beyond the point where the sideband unit and the sweep generator are connected. Crystals with fundamentals of 1 or 1.5 mc will place check points across the entire curve. Once a specific point on the curve is marked with a high-frequency crystal (such as a 4.5-mc unit), the close-spaced pips may be used to identify the frequency of points all along the response curve.

3. **High-frequency crystal detector and heterodyne mixer.** With the power disconnected, the crystal diode circuit of the sideband modulator may be used to indicate r.f. power at frequencies extending through the u.h.f. television bands. A microammeter connected to either J1 or J2 (observe polarity of current flow) will indicate r.f. fed into the opposite connector. If enough r.f. voltage is present in the sources, two signals may be fed into one connector and the difference frequency recovered from the other. The difference signal can then be amplified by any appropriate amplifier (i.f. strip, video amplifier, scope or audio amplifier, depending on the range of difference frequencies involved). Variations in the output amplitude of sweep generators across a given sweep band can be checked by feeding the swept signal into J1 and viewing the output from J2 on a high-gain oscilloscope.

4. **TV horizontal linearity bar-pattern generator.** For this function, the

sideband unit is supplied with a marker frequency corresponding to any convenient video channel, or a submultiple thereof. A low-frequency crystal (100–250 kc) inserted into the modulator will produce a number of vertical bars on the picture tube. Adjustments can then be made to give the best equal spacing of the bars. For best results as a bar-pattern generator the unit should have a d.c. plate supply. END

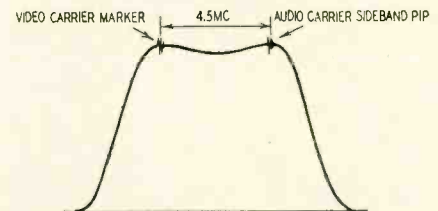

Fig. 3—A front-end response pattern.

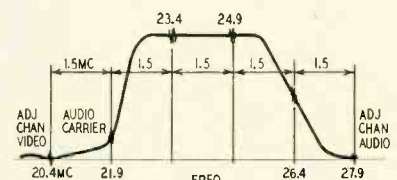

Fig. 4—Sideband unit provides pips.

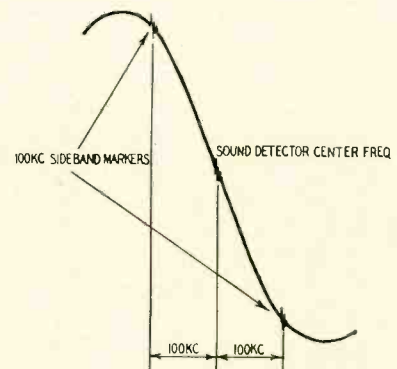

Fig. 5—Sound detector response curve.

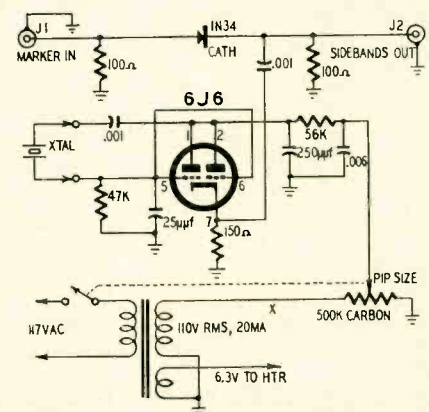

Fig. 6—Schematic diagram of the sideband modulator without a d.c. supply.

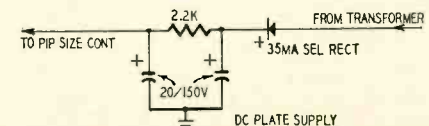

Fig. 7—Diagram of d.c. plate supply.

Parts for sideband modulator (Fig. 6)

Resistors: 2—100, 1—150, 1—47,000, 1—56,000 ohms, 1/2 watt; 1—500,000 ohms, potentiometer.

Capacitors: 1—25 µf, 1—250 µf, 2—.001 µf, 1—.006 µf.

Miscellaneous: 1—IN34 crystal; 1—power transformer, primary: 117 volts, secondary: 110 volts @ 20 ma, 6.3 volts @ 0.3 amp (Burstein-Applebee No. 19C714 or equivalent); 2—connectors (Amphenol 83-IR or equivalent); 1—on-off switch (may be mounted on potentiometer); 1—crystal holder; 1—7-prong miniature socket; 1—6J6; 1—Minibox chassis, 2 x 3 1/4 inches; 1—knob for potentiometer.

Parts for d.c. power supply (Fig. 7)

1—2,200-ohm resistor, 1/2 watt; 1—35-ma selenium rectifier; 1—20–20 µf 150-volt electrolytic capacitor.

A LABORATORY TYPE TUBE TESTER

A checker to meet the demands of increasingly complex equipment

By JOHN A. DEWAR

TRANSCONDUCTANCE tube testers are a great improvement on the emission type but have their limitations. The instrument described in this article (Fig. 1) is superior to them in that it tests tubes under working conditions: grid bias and plate and screen voltage can be set to any desired value. Plate and screen currents are metered and transconductance is read directly by applying a 1-volt r.m.s. signal on the grid and measuring the output in a.c. milliamperes.

The instrument is not as complicated to operate as the large number of controls would suggest and, while it takes longer to test a tube, it actually saves service time by accurately establishing a tube's condition.

A Heath emission type tester built in the unit simplifies construction. It can be used as an emission tester, as originally designed, to test diodes, rectifiers and for short-circuit tests. For transconductance tests the Heath tester supplies the sockets, heater voltage, line meter, and line voltage adjust for the bias supply and audio oscillator. Any free-point tester can be used in the same way.

Oscillator and bias supply

Fig. 2 shows the half-wave rectifier that supplies up to 40 volts negative bias, the full-wave rectifier that supplies the oscillator and the meter that measures injection signal voltage. Potentiometer R1 adjusts the negative grid bias. The 1-volt grid input signal is adjusted by R2 and metered by the 6C8-G and 0-2-ma meter. One section of the 6C8 is used as an isolating cathode follower to prevent clipping of the signal voltage; the other section is a d.c. amplifier, making a sensitive meter unnecessary. The 0-2-ma meter was calibrated to read 0-3 volts a.c. at 2,000 cycles.

An audio oscillator operating in the region of 2,000 cycles was chosen in preference to the 60-cycle line frequency because it produces less loss in the plate

a.c. meter. For instance, with the setup shown in Fig. 3, a 1-volt 60-cycle signal shows only 30% of the output compared to a 2,000-cycle signal.

The oscillator transformer is a 1:1 push-pull input in a Hartley circuit. Since the center tap overexcites it, some juggling with plate voltage, grid resistor and capacitor was necessary to produce a good sine wave. It may be necessary to depart from specified values when a transformer of another make is used. Loading the secondary with the 10,000-ohm potentiometer decreases the effective primary inductance, increasing the frequency and improving the waveform.

Plate and screen supply

The 1619 tubes act as rectifiers (Fig. 3) and variable voltage controls at the same time—the two 500,000-ohm poten-

tiometers vary the grid voltage. The power transformer is a replacement type for 2.5-volt radios (can be taken from an obsolete radio). It should have two 2.5-volt windings or the 5-volt winding can be reduced to 2.5 volts with a series resistor.

Screen voltage can be varied from 50 to 400. The plate supply can be varied from 50 to 400 volts except with output tubes drawing a large current, which drops it to 250 volts at 50 ma. A higher voltage transformer would increase the plate supply voltage but 250 volts is adequate. Since the screen current requirements are small, any high-resistance choke or audio transformer winding can be used for filtering.

The a.c. component of the plate current is the measure of a tube's transconductance. With 1 volt a.c. applied to the grid, the a.c. plate current can be

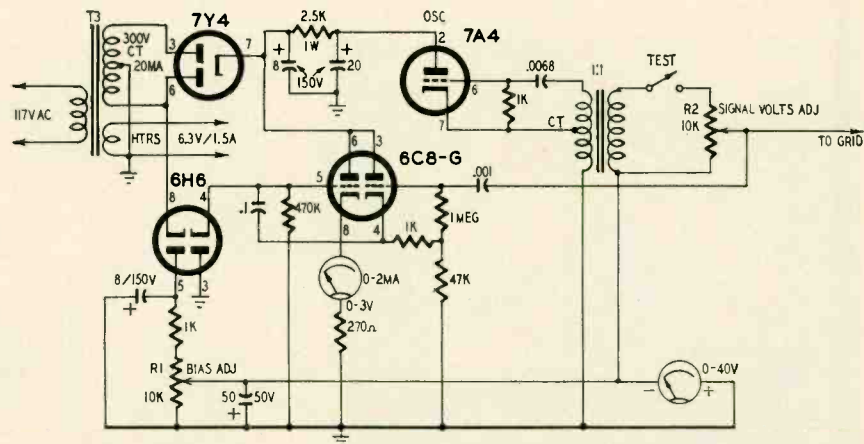

Fig. 2—Schematic diagram of the audio oscillator and the grid bias supply.

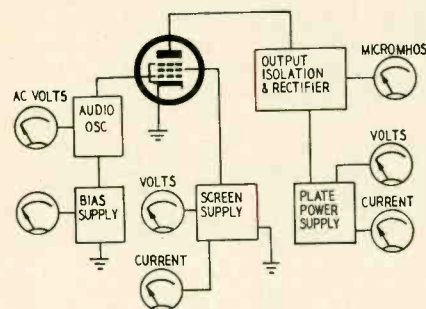

Fig. 1—Block diagram shows basic layout of the laboratory type tube tester.

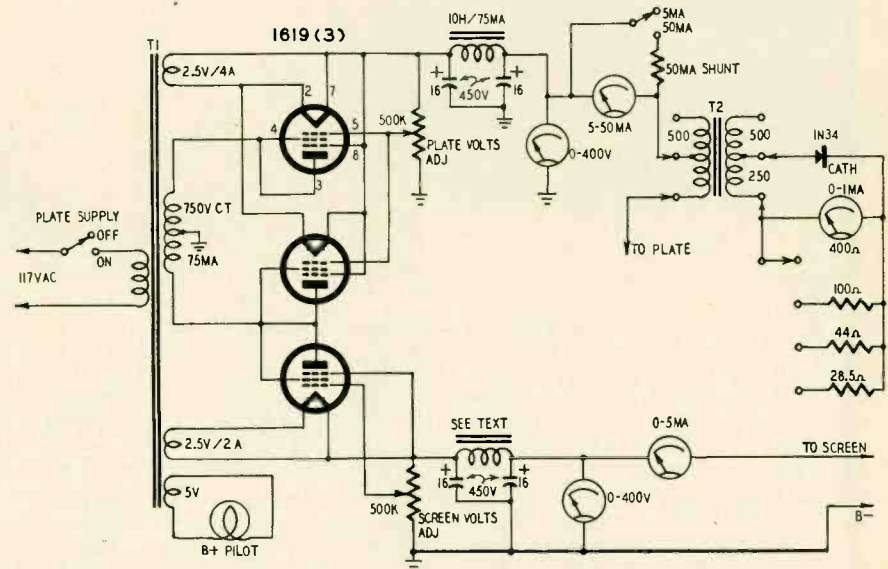
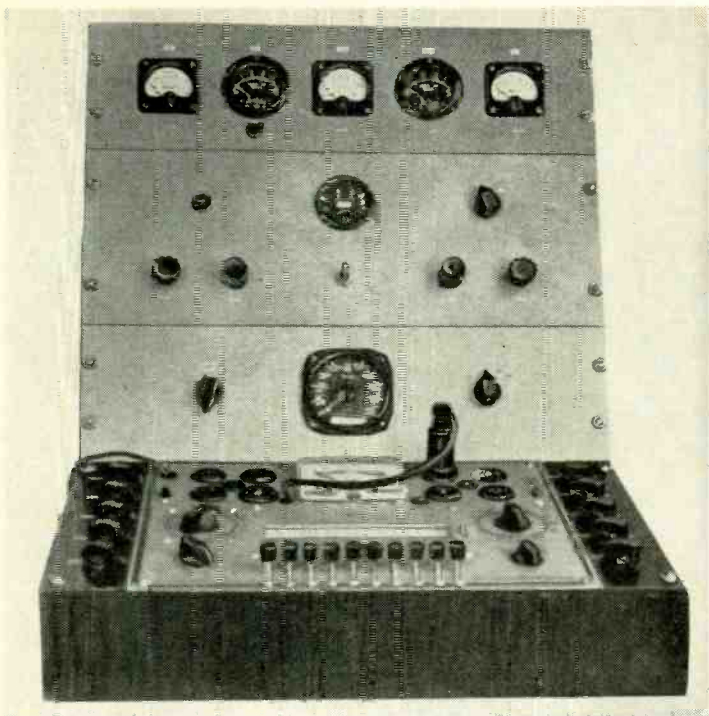
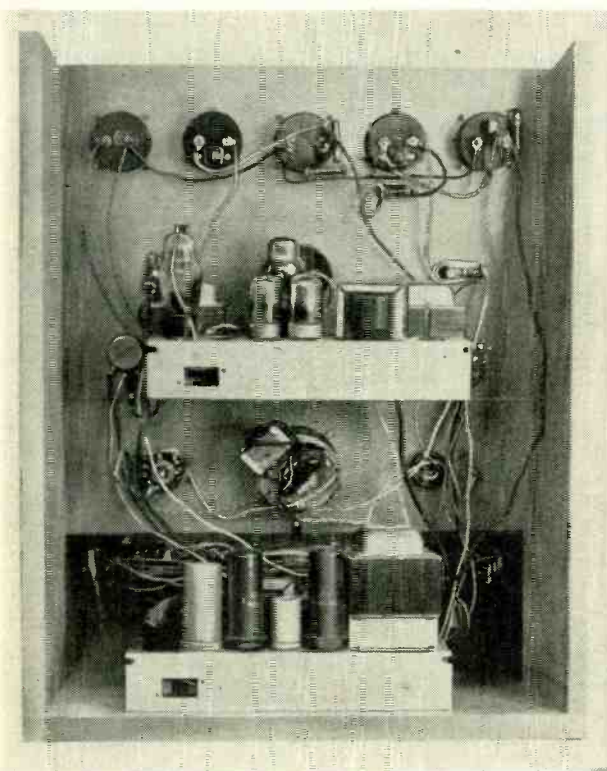

Fig. 3—Schematic of plate and screen supply of the transconductance meter.

TEST INSTRUMENTS



Front of the laboratory type tube tester.



Rear view—chassis and major components.

easily translated into micromhos; that is, 1 milliamper a.c. is equal to 1,000 micromhos. Measuring this a.c. poses several problems: the d.c. plate current component must be isolated, losses must be kept to a minimum, and the impedance introduced in the plate circuit must be kept to a low value compared to the tube's load resistance.

Many arrangements were tried and the circuit shown in Fig. 3 proved best. For isolation, a line mixing transformer is used. This has a center-tapped 500-ohm primary and a 500-ohm secondary

with 250- and 500-ohm taps. Its current rating is 100 ma. Secondary current is rectified by a 1N34 crystal diode and measured on a 0-1-ma meter. This combination is efficient but some losses occur so it is necessary to increase the signal voltage to slightly above 1 to compensate for them.

The 3-inch meter used has a basic movement of 1 ma, with 400 ohms internal resistance. It is from a surplus altimeter and has a 260° scale which gives lots of room for calibration. A total of four calibration ranges were

used with the 1-milliamper meter:

1. Basic 0-1 ma—0-1,000 μ mho
2. 100-ohm shunt, 0-5 ma—0-5,000 μ mho
3. 44-ohm shunt, 0-10 ma—0-10,000 μ mho
4. 28.5-ohm shunt, 0-15 ma—0-15,000 μ mho

A new meter scale, calibrated in micromhos, was made by cementing numbers (cut from a tube manual) on thin black card pasted over the original scale. For a meter of different internal resistance other values of shunt resistance must be calculated.

In testing filament type tubes the a.c. in the filament causes an a.c. voltage to appear on the grid, giving a reading on the output meter. To balance this out a 100-ohm potentiometer (Fig. 4) is connected from 0 to the 3.3-volt tap on the filament transformer (in the Heath kit tester) and the B minus or ground connection to the moving arm. This is adjusted for zero reading on the output meter before the tube is tested. For cathode types it is set to off position.

Construction

Standard 19-inch steel panels were used, screwed to a wooden rack. I recommend some more easily worked material than steel. The instrument shown in the photos is larger than necessary. This was an experimental model and I allowed space for changes and additions.

The outlay in time and material to build this tester is considerable but well worth while in view of its usefulness. A similar manufactured job costs in the neighborhood of \$1,000.

Ten single-pole 5-position rotary switches are grouped, five on either side of the emission tester. These are numbered and connected as follows (see Fig. 5): Switch 1 connects to pin 1 on all sockets; switch 2 connects to all No. 2 pins, and so on. On the Heath tester the lead from pin No. 1 on all sockets is removed from switch A and connected to position 1 on switch 1. This is marked RETURN and connects back to lever switch A. Similarly with switches B through to K. All tube-element selector switches are marked:

Position

1. Return—back to emission tester
2. Plate—to output meter and plate supply
3. Screen—to screen supply
4. Grid—to audio oscillator and bias supply
5. Off—open circuit

The five meters on the top panel are: Plate volts, 0-400; plate current, 0-5-50 ma (value of shunt must be calculated from meter's resistance); screen volts 0-400; screen current, 0-5 ma; grid bias volts, 0-40. To keep construction costs down surplus meters with 5-ma movements were used. These act as light bleeders on the power supplies, a desirable feature. To have all pertinent measurements simultaneously

indicated without switching is a great advantage since plate, screen and bias variations interact and must be observed for a final adjustment. The meters are shown in the schematics with their associated equipment and not separately, as on the panel.

Calibration

Scale multiplication can be checked by setting a tube to read exactly 1,000 μ mho. Switch to the 5,000- μ mho range and check that it reads 1,000. Similarly adjust another tube to 5,000 μ mho and switch to the 10,000- μ mho range, and so on.

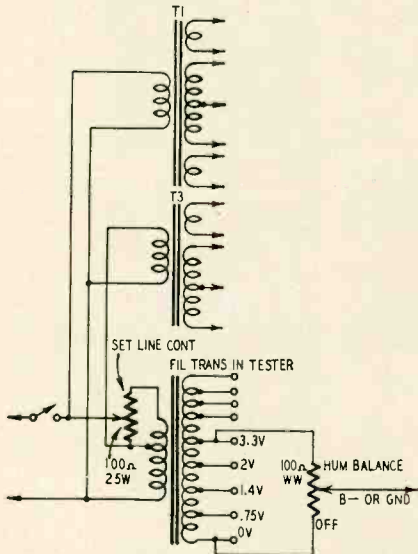

Fig. 4—Connecting the hum-bucking potentiometer to the filament transformer.

Accuracy of measurement can be checked by using a number of known good tubes of the same type and taking an average of them. They will vary because of production tolerances. Plate, screen, bias and heater voltages must be accurately set. Check accuracy of instrument meters with a v.t.v.m. known to be accurate. The signal-voltage meter (basic 0-2 ma) was calibrated against an a.c. v.t.v.m.

High-transconductance type tubes tend to oscillate at u.h.f. in some testers,

Parts for tube tester

Resistors: 1—270, 3—1,000, 1—47,000, 1—470,000 ohms, 1—megohm, 1/2 watt; 1—2,500 ohms, 1 watt; 3—precision resistors (meter shunts, see text); 1—100-ohm wirewound potentiometer; 2—10,000, 2—500,000 ohms, potentiometers.

Capacitors: 1—.0068 μ f, 1—.001 μ f, 1—0.1 μ f, 200 volts; 1—8 μ f, 1—8-20 μ f, 150 volts, electrolytics, 1—50 μ f, 50 volts, electrolytic, 2—16-16 μ f, 450 volts, electrolytics.

Miscellaneous: 1—7Y4, 1—7A4, 1—6H6, 1—6C8-G, 3—1619, tubes; 2—0-400 volts, 2—0-5 ma, 1—0-1 ma, 1—0-2 ma, 1—0-40 volts, meters; 1—1N34; 1—pilot lamp and holder; 1—power transformer, 2.5 volts @ 4 amp, 2.5 volts @ 2 amps, 750 volts c.t. @ 75 ma; 1—power transformer, 300 volts c.t. @ 20 ma, 6.3 volts @ 1.5 amp; 1—choke, 10 h @ 75 ma; 1—choke (see text—any high-resistance choke or audio transformer winding); 1—oscillator transformer, 1:1 ratio, 1 side center-tapped; 1—line mixing transformer, primary 500 ohms, secondary, 500 ohms with a 250-ohm tap; 3—s.p.s.t. switches; 10—single-pole 5-position switches, rotary non-shorting; 1—chassis for oscillator and bias supply; 1—chassis for plate and screen power supply; 1—emission type tester; 1—single-pole 4-position rotary switch; 1—mounting panel.

giving an inaccurately high reading. This tester has not shown such a fault. In fact in several months' use it has proven accurate, very useful and free from bugs.

Operation

Since the emission tester's lever switches A to K represent pin connections 1 to 10, these have been so numbered on the panel for ready reference. In center (neutral) position all connections are to the filament tap. Similarly, the other 10 element switches are on RETURN. Using a tube manual, let us test a 6K7. Plate supply off. Test for shorts. Then:

- Pin 1—shield. Lever switch down, to ground.
- Pin 2—heater—center, as is.
- Pin 3—plate—lever down, switch 3 to plate.
- Pin 4—screen—lever down, switch 4 to screen.
- Pin 5—suppressor—lever down to ground.
- Pin 6—no connection—center, as is.
- Pin 7—heater—lever down. Filament selector to 6.3 volts.
- Pin 8—cathode—lever down to ground.
- Cap —grid — lever 10 down. Switch 10 to grid.

Turn on B plus. Consulting tube manual set:

- Plate current range to 50 ma.
- Plate volts to 250.

Screen volts to 100.

Grid bias to -3 volts. (It is advisable to keep the bias high at the start to prevent plate current meter overload.)

Set output range to 5,000 μ mho.

Depress test switch, set signal volts to 1, read micromhos.

Plate current should be around 7 ma, screen current 0.8 ma.

Transconductance should read around 1,450.

The tubes indicated were used because they were on hand. Any other tubes of similar type can be substituted, such as: 6X5, 6X4 for 7Y4; 6J5, 6C5, etc. for 7A4; 2A3, 6L6, 807, etc. for 1619. Of course 6L6's or 807's will require a different power transformer, with 6.3-volt windings and the B plus switch changed from the line to the B minus return because they are slow to heat.

Substituting for the 6C8 would require circuit changes. Values chosen for the d.c. amplifier were picked for this tube and meter. A few additional notes: Always have the plate supply off when setting switches. Start setup with the 10 element switches on RETURN and lever switches in center—neutral. Check to see that all switches are correctly set before turning on power supply. See that line voltage meter is on "line test" to insure correct heater voltage.

Complete flexibility allows tests under widely varying conditions and the drawing-up of E_g - I_p curves and other characteristic graphs. END

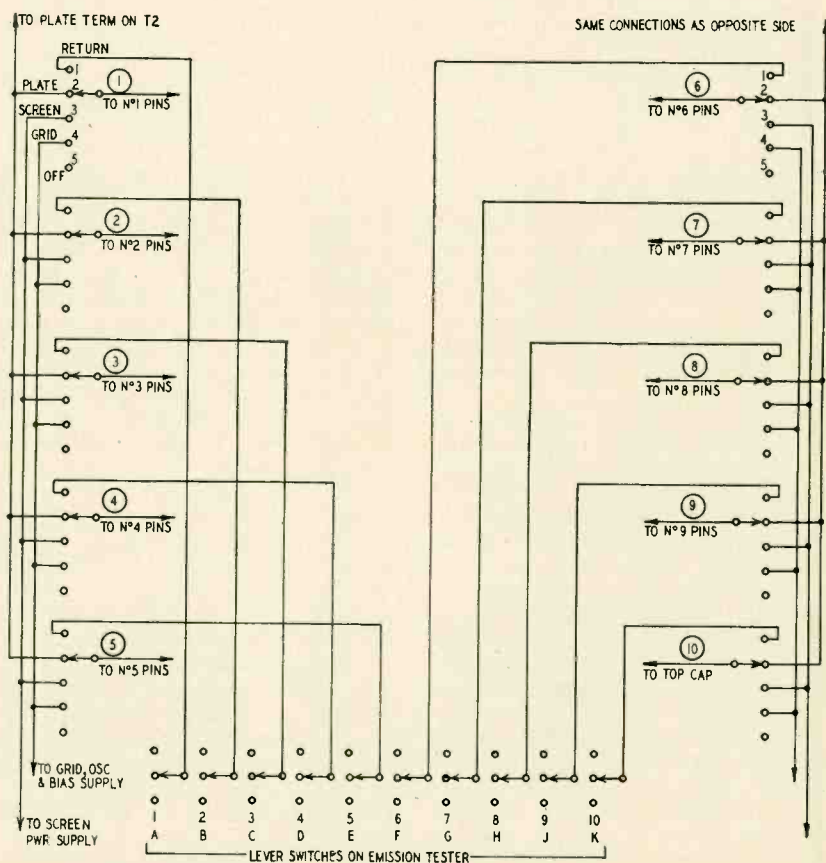

Fig. 5—Tube-element selection switches connected to the emission tester.

+

CAPACITOR TESTING

with your OHMMETER

Used with multimeter, unit provides reliable check

By SOL D. PRENSKY

THE ohmmeter, so tremendously useful for continuity and resistance checks, is no great shakes for capacitor testing. The service technician generally makes fine use of the versatile volt-ohm-milliammeter; but when it comes to testing capacitors, he finds that the resistance-measuring circuit of the ohmmeter gives him only a very limited ability to spot an open or a badly shorted capacitor. It fails to give any effective overall "good-or-bad" test on many important in-between defects.

The weakness of the ohmmeter circuit in testing capacitors stems from the fact that it basically measures current flow in a low-voltage battery circuit. Thus, the ohmmeter is virtually useless for indicating critical capacitor leakage at rated voltage.

Consequently, when the occasion arises where a capacitor must be tested, the technician has two alternatives: He may use a capacitor tester which provides leakage and capacitance measurements under rated-voltage conditions, or stoop to the time-wasting system of substituting good capacitors all over the lot.

Many manufacturers of 20,000-ohm-per-volt multimeters include directions for capacitor testing in their instruction booklet. Such directions, in general,

point out that it is possible to use the current ranges (and sometimes voltage ranges) to measure leakage by placing the milliamperage range of the meter into the power supply of the set, in series with the suspected capacitor. This method, while theoretically giving a much better test, is not very satisfactory from a practical standpoint. Among other things, it involves using the current range of the meter on the live set. It would be much better if we were able to retain the advantage of test-prod probing with the multimeter without the danger of damage to the meter by incorrect operation with the set turned on. Such a method is described in this article.

The primary objective of this unit is not to measure capacitance, but to provide on the meter a *practical good-bad indication* of the merit of the capacitor. The neon lamp serves in a minor role, absorbing large discharge currents. While doing this, it shows the heavy discharge currents to be expected from large electrolytics (4 to 40 μ f). Though the neon flash might be used for a fast check on these capacitors, the determination of discharge ability is available on the meter at all times.

The capacitor tester (see photo) is compact, small enough to be attached

Underchassis view of the test unit.

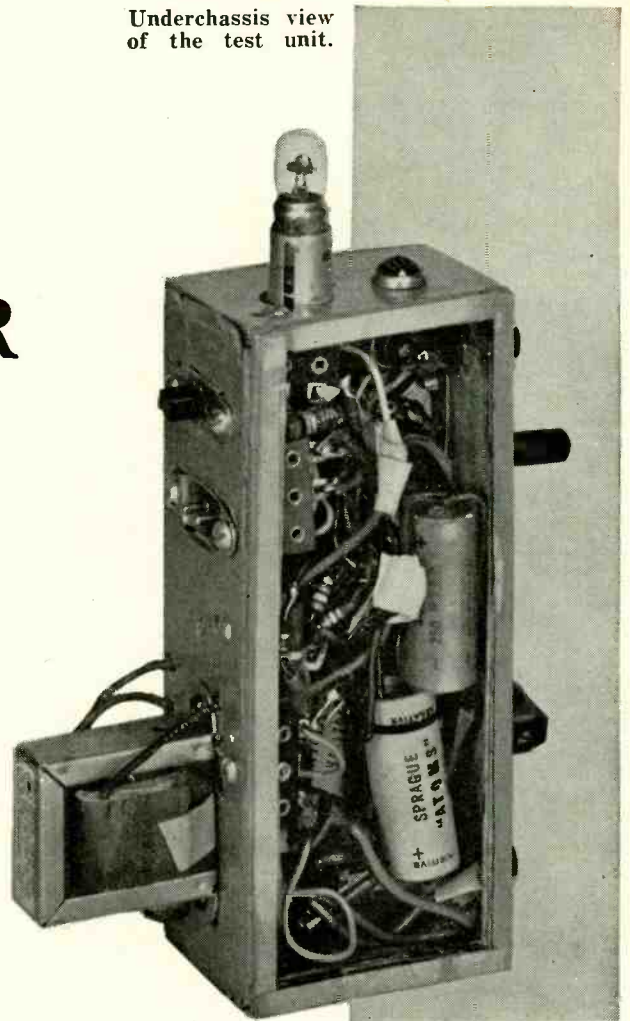

to the side of a multimeter without interfering with the portability of the instrument. It provides:

1. A power supply for 25, 50, 150, 300 and 450 volts d.c. output.
2. A leakage measurement by the current scale of the meter, on charging a capacitor—with the meter circuit fully protected during this test.
3. A discharge test with indication, in the meter circuit, of the charge-holding ability of a capacitor.
4. Switching circuits for applying the proper value and polarity of test voltages, according to the type of capacitor being tested.

Circuit operation

The d.c. test voltages are obtained from the self-contained power supply and are selected by the six-position switch. The test voltages are produced in the power supply (Fig. 1) by a selenium rectifier stack arranged in a voltage-tripler circuit. The current requirements for these test voltages are very modest, being no more than around 50 ma for short periods—the maximum leakage expected from even the largest good electrolytic that would commonly be tested (100 μ f at 450 volts). Current demand for more than 50 ma occurs only with defective capacitors. In these cases, any larger current need

TEST INSTRUMENTS



The test chassis in operating position.

flow only for the few seconds it takes to determine that the capacitor is bad. There is, therefore, no problem with temperature-rise effects from continuous current, and the power supply can be made inexpensive and compact. Operating from an isolation transformer, the supply uses three miniature (65-ma) selenium rectifiers and instantly produces the required test voltages. The maximum current delivered by the supply is limited by R1 and R2 to a safe value for the meter, so that relatively large instantaneous charging currents or even a dead short will not cause excessive meter overload.

Capacitors are tested in the charge (Fig. 2) and discharge (Fig. 3) circuits. The capacitor to be tested is first isolated by lifting one end free while the set or other device of which the capacitor is part is de-energized. Jumper leads from the capacitor tester pin jacks are plugged into the meter, and the regular test leads are used at two other pin jacks of the tester. Up to this point no testing action takes place, since the charge-discharge switch is still open, allowing the connections and the meter-range switch positions to be checked for correct test conditions, as given in the tables.

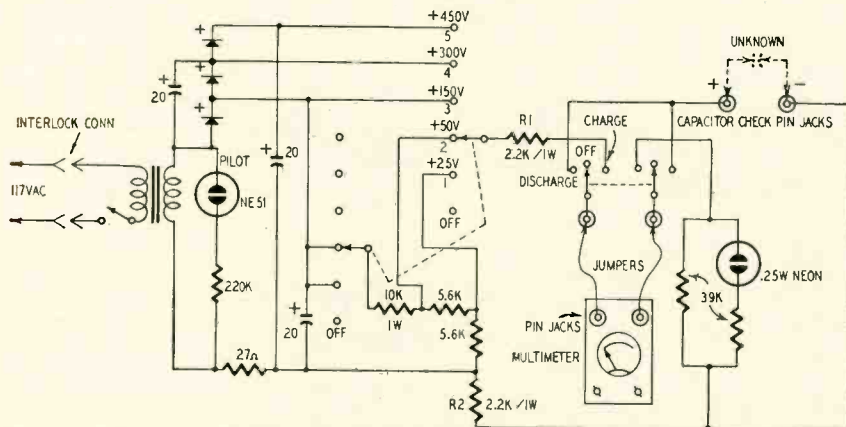

Fig. 1—Schematic diagram of the capacitor test unit. All values are shown.

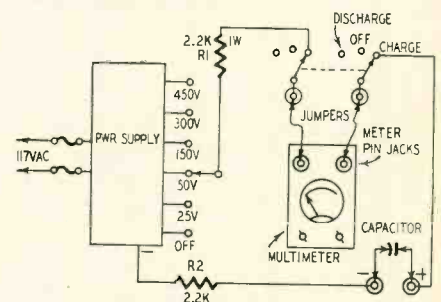

Fig. 2—Schematic of the charge circuit.

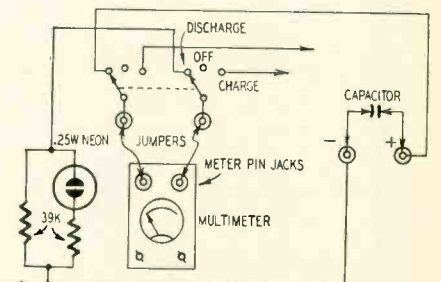

Fig. 3—The basic discharge circuit.

When a capacitor is to be tested, turn on the power to the capacitor tester. The testing steps follow the order given in the test table. The following points are in addition to the directions in it.

1. Set selector switch to test voltage desired (25, 50, 150, 300 or 450), preferably using wherever possible the test voltage next higher to the rated d.c. working volts.

2. The meter range for CHGE position is set for MA (d.c.) or D.C. volts as directed by the tables. (On the d.c.-volt range, the charging current flows through the input resistance of the meter and gives a very sensitive but safe current range—about 50 μ a—even though we read on the voltage scale.)

3. Press CHGE switch. The meter pointer will swing over and then stabilize. (With electrolytics, allow time for the capacitor to form, especially if it has been out of use for some time.) If leakage current is excessive after the needle stabilizes—within a few seconds—the capacitor should be rejected. Otherwise, proceed with the next step.

4. Return the CHGE-DISCH switch to neutral mid-position.

5. The meter range for DISCH position is then set. This is usually some a.c. volts range on the multimeter, where the nonlinear action of the meter rectifier is used to produce a more easily read discharge indication. Up-scale deflection of the meter on DISCH is obtained by the circuit-reversing action of the switch in DISCH position. This also produces forward current through the meter rectifier in the usual 20,000-ohm-per-volt type of multimeter circuit. (This can easily be checked for a particular multimeter by reversing the leads to the multimeter terminals before pressing the DISCH switch and observing which connection gives the larger reading.)

TEST INSTRUMENTS

6. Press lever switch to DISCH position. Observe movement of the meter pointer for its maximum swing past the value indicated in the discharge column of the tables. If the required needle swing is obtained, it shows adequate charge-holding ability, and the capacitor may be considered good.

As an example of operation, let us take a good 20- μ f 150-volt capacitor. After making the necessary connections, set the selector switch of the unit to position 3 (150 volts) and the meter range to 120 ma. When the lever is pressed to CHGE (charge), the meter pointer swings over for the forming and charging current and then quickly stabilizes at a low value. With the meter range reduced to 12 ma, the reading is still low. When the meter range is further reduced to 1.2 ma, the leakage current can be read as, say, 1 ma, which is much less than the allowable 0.2 ma per μ f (4 ma in this instance). Return the lever to its neutral (center) position. With the meter range now set at 300 volts a.c., press the lever to DISCH. The meter pointer swings past the half-scale reading required and the test is completed. (The flashing of the neon is incidental but it may be used by noting its duration, especially if a quantity of 20- μ f 150-volt capacitors are to be checked.)

The test tables may be made more detailed by adding specific good-bad values for commonly used sizes of capacitors, in much the same manner as in a good-bad tube-testing chart.

Further development versions

For construction purposes, the capacitor tester has been presented here in a form that may be conveniently built for use with the most commonly available meters such as the Precision model 85. The usefulness of the tester may be further developed by greater compactness and use with a v.t.v.m.

One version of the miniaturized unit is shown in the photo: the components have been fitted into a box small enough to become a permanent addition to the multimeter. The small size is made possible by using a Switchcraft type



Miniature tester mounted on meter.

Parts list for capacitor tester

Resistors: 1—27, 2—5,600, 2—39,000, 1—220,000 ohms, 1/2 watt; 2—2,200, 1—10,000 ohms, 1 watt.

Miscellaneous: 3—20- μ f 450-volt electrolytic capacitor (Astron MM 20-450 or equivalent); 1—s.p.s.t. switch; 1—d.p.d.t. switch (neutral center position); 1—2-pole 6-position rotary switch (Mallory 3226 J or equivalent); 1—dial plate for rotary switch; 1— isolation transformer, 10 watts, 120 volts to 120 volts (Stancor PS-8415 or equivalent); 3—selenium rectifiers, 65 ma, approximately 1/2-inch cube (International Rectifier Corp.); 4—pin jacks; 1—line cord (removable, TV type); 2—jumper leads with phone-tip plugs, 6-inches or longer; 1—NE51 lamp and assembly; 1—1/4-watt neon lamp and holder, for discharge; 1—chassis.

TEST TABLE I—ELECTROLYTICS

CHARGE TEST				DISCHARGE TEST	
D.C. V.V.	Sw Pos.	Meter Range ¹ (ma)	Allowable Leakage ² (for 20- μ f unit)	Meter Range	Allowable Indication (for 20- μ f unit)
450	5	Start at 120	4 ma (0.2 ma/ μ f)	12 ma	6 ma (past 1/2 scale)
300	4	Start at 120	2 ma (0.1 ma/ μ f)	300 v.a.c.	200 v (past 2/3 scale)
150	3	Start at 12	1 ma (0.05 ma/ μ f)	300 v.a.c.	150 v (past 1/2 scale)
50	2	Start at 12	0.5 ma (.025 ma/ μ f)	60 v.a.c.	30 v (past 1/2 scale)
25	1	Start at 12	0.5 ma (.025 ma/ μ f)	60 v.a.c.	15 v (past 1/4 scale)

For meters with d.c. resistance of 20,000 and a.c. resistance of 1,000 ohms per volt

¹After charging (or forming) surge, reduce range to lowest safe scale for accurate stabilized reading.

²Allowable leakage for practical replacement purposes.

[These values are about twice the RETMA standard for new capacitors given by the formula: Leakage current = (factor $\times \mu$ f + 0.3) ma. Factor varies from .01 at 25 volts to .04 at 450 volts.]

TEST TABLE II—NONELECTROLYTICS

Sw Pos.	Capacitance (μ f)	Voltage	CHARGE TEST		DISCHARGE TEST	
			Meter Range (volts d.c.)	Allowable Leakage ² (meter divisions ¹)	Meter Range (volts d.c.)	Allowable Indication (approx. pointer swing ³)
5	1 or over	600	1,200	Below 6	1,200	2/3 scale
		400				
5	0.5-0.9	600	1,200	Below 4	1,200	1/2 scale
		400				
5	0.1-0.4	600	1,200	Below 2	1,200	1/3 scale
		400				
5	0.5-0.9	600	300	Below 2	300	2/3 scale
		400				
5	.01-.04	600	300	Below 2	300	1/3 scale
		400				
5	.001-.009	600	300	Below 1	300	1/12 scale
		400				
5	.005-.009	600	150 (v.t.v.m.)	Below 2	150 (v.t.v.m.)	1/3 scale
		400				
5	.001-.004	600	150 (v.t.v.m.)	Below 2	150 (v.t.v.m.)	1/4 scale
		400				

(Based on resistances of 20,000 ohms per volt d.c. and 1,000 ohms per volt a.c., except where v.t.v.m. is indicated)

¹Each division on 20,000-ohm voltmeter equals 50 μ a divided by number of divisions.

²For critical applications such as coupling capacitors, reading should be practically zero and definitely less than 1 μ a. All indications are for stabilized readings.

³Discharge swing should be approximately equal to charge swing. For comparing swings be sure to obtain full swing of each, using lever action, repeated if necessary. Exact readings are not necessary—appreciable difference will be noted with bad capacitor.

miniature switch and dual-section common-negative can type of electrolytic. The temperature rise of the selenium rectifiers is small enough to be neglected, permitting the close placement of components. An Alden miniaturized pilot light and neon lamp would save still more room.

Extension of the range to smaller capacitor values by the use of a v.t.v.m. as indicator is indicated in the last items of the test table. The test results for capacitors between .001 and .009 μ f are given first for the multimeter and then repeated for the v.t.v.m. The v.t.v.m. is a Heathkit V-6 model, having an input impedance of 11 megohms, as compared to the 20,000-ohms-per-volt type multimeter impedance of 6 megohms on its 300-volt d.c. range. What is more important, the v.t.v.m. (on its 150-volt d.c. range) gives a current sensitivity for leakage measurements many times as sensitive as the approximate 1- μ a-per-division sensitivity of the multimeter on its d.c. voltmeter range.

The v.t.v.m. will give, not only a more sensitive leakage indication (desirable for mica and ceramic capacitors), but also a much larger pointer swing on charge and discharge tests, when the pointer swing becomes too small for good readings. The v.t.v.m. range scale (of the Heathkit meter) can be successively reduced from 150 volts d.c. down to 50, 15, 5 and 1.5 to handle smaller capacitor values. These more sensitive ranges must be used with proper care, switching them in only when the higher range gives too small a deflection.

END

The polariscope produces color patterns similar to those shown on our front cover.

STRAIN

in VACUUM TUBES

Tube manufacturers check the glass envelopes of tubes to assure strength and long life

By VINCENT C. De MARIA*

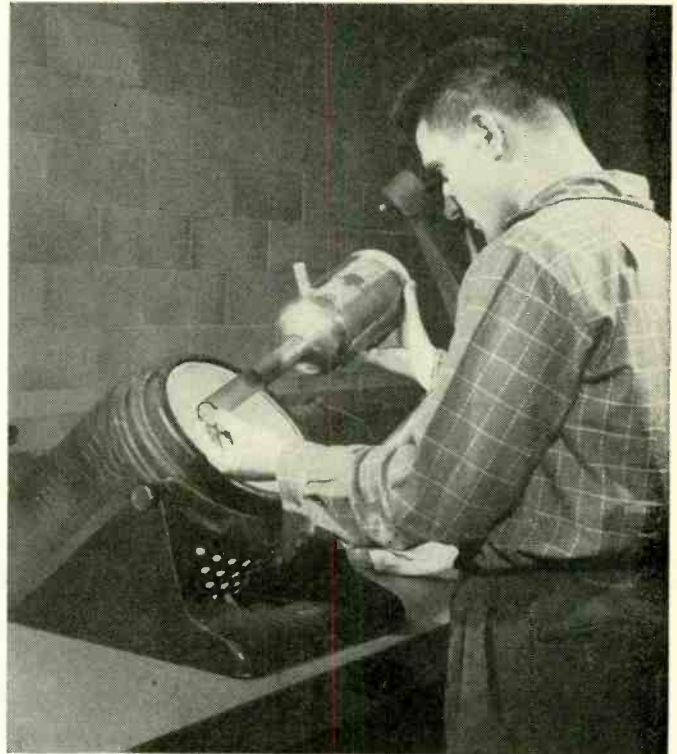

THE residual stresses in an evacuated electron tube envelope are of major concern to tube manufacturers. Any strain weakens the glass and makes it more liable to failure when treated roughly, as when inserting or removing the tube, subjecting it to blows or friction or even to the expansion and contraction due to temperature changes in the equipment.

Strains in glassware can be observed with a polariscope, the instrument used to produce the photograph shown on the front cover. It consists essentially of a light source, two Polaroid films with optical axes at right angles to each other and a tinted plate for imparting color. The photograph on this page shows a technician checking for strains in the neck of an experimental cathode-ray tube. Strains are seen as color patterns and give an approximation of the amount of stress. The polariscope indicates the nature of the strain forces, either tensile or compressive, by hues comparable in beauty to nature's rainbow.

In the ever-continuing search for means of reducing strain, alloys have been developed¹ for glass-to-metal seals in which both glass and metal contract at the same rate when cooled from the high temperatures of the manufacturing and sealing processes. Electronically controlled annealing furnaces further relieve the stresses created

during manufacturing. The recent application of strain gauges² to obtain strain data further aids in providing larger and safer cathode-ray tubes.

Television technicians and others responsible for the placing or mounting of electron tubes play an important role in maintaining stress-free, and therefore long tube life, conditions. Many cases of glass envelope failure in sealed tubes have been due to failure to follow established precautions:

1. When fastening vacuum tubes by the glass envelope, as is often done with picture tubes, a resilient rubber or felt material should be used between the metal mounting bracket and the glass tube envelope.

2. Surface abrasion should be prevented—it weakens the glass structure appreciably. Surface scratches may be caused by placing cathode-ray tubes on a table top or other hard surface without a compressible material between the tube face and table. Other causes of surface abrasion are adjusting ion-trap magnets and inserting tubes in cramped locations while wearing hard gem rings, and storing spare tubes in bulk without their protective cartons.

3. Any leverage effect which results in tensile forces must be eliminated. Such forces are produced when pressure is applied at the neck or base of a securely mounted tube when adjusting or mounting deflection yokes, focusing coils or magnets and ion traps.

Do not conclude from the above that all strains in glass are harmful. Strain has its brighter side and is often introduced intentionally under controlled conditions. Mechanical strength and resistance to thermal shock are increased when the surface of glass is placed in compression. This so-called tempered glass is used in rear-view automobile windows, glass doors and some airplane windshields.

The electronics industry takes advantage of controlled stresses in fabricating the tube presses (stems) which contain the wires that support the electronic elements. By properly adjusting the annealing cycle, strains are left in the glass and can be seen when viewed in the polariscope at room temperature. When the tube is operated at high temperatures, reverse forces are created and the glass stem becomes stress-relieved.

The colors seen in the polariscope are among the most valuable aids in detecting and correcting harmful strain patterns. The manufacturers' efforts toward eliminating weakening factors, plus proper handling by those responsible for installation, will go far to provide safe and economical operation of electron tubes. END

References

- ¹U. S. Patent 2,371,627.
- ²A. Cohen and R. F. Doran "The Use of Strain Gauges for Determining the Pressure-Strain Relationship in Television Envelopes," *Bulletin of the American Ceramic Society*, Vol. 33, page 1, January 1954.

*Sylvania Electric Products Inc., Bayside, N. Y.

SCANNING WITH ULTRASOUND

By S. M. MILANOWSKI

ULTRASONIC scanning techniques are among the most important methods of locating hidden flaws in materials such as brass, steel, aluminum, plastics and ceramics—many of which could not be satisfactorily tested with X-rays or other means.

Some engineers still maintain that ultrasonic scanning will eventually become a standard feature of all television receivers, since light modulated by ultrasound produces exceptionally sharp and bright images. But they also agree that such scanning will not become completely practical until present television systems have been greatly simplified.

Initial efforts to use ultrasound for industrial test purposes in both the United States and Europe consisted of projecting high-frequency vibrations from a transducer through a material, to a receiving device—much the same as X-rays are used. This was an effective method of testing relatively thin sheet or plate materials, because the intensity of ultrasonic vibrations penetrating a material is proportional to the density (and thus the quality) of the material.

It was not a practical method of testing most materials because sonic impulses traveling from one medium into another have a tendency to become echoes and thus lose their ability to penetrate. For example, if an ultrasonic impulse is sent through a heavy forging, much of the energy of the impulse will be lost when:

1. The surface of the forging that is closest to the transducer or generator produces an echo.
2. Flaws of foreign matter, if any, within the forging produce echoes.
3. The surface of the forging farthest away from the transducer or generator produces an echo.

Industrial engineers soon began to investigate the possibility of using ultrasonic echoes to determine the presence or absence of flaws in various industrial materials. This was a difficult task, despite the fact that ultrasonic echo devices had been used as depth finders aboard vessels since about 1912, and much had to be learned about the acoustical properties of numerous materials.

The first industrially practical echo test devices were developed almost simultaneously in England, Germany and the United States during World War II. Most of these were similar to, if not precisely the same as, the *Ultrasonic Reflectoscope* produced by Sperry Products, Inc., Danbury, Conn.

*A fascinating application
of sound energy*

Ultrasonic equipment indicated crack in specimen and was sustained when specimen was cut. X-rays did not show flaw.

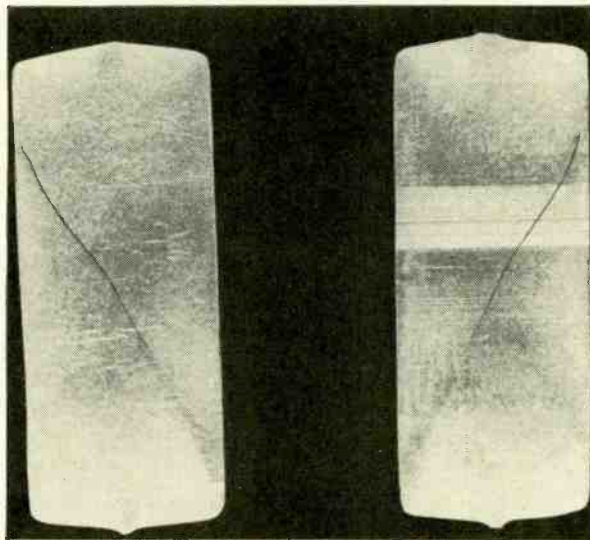

Scanning image. Long white line represents upper surface of material. Dots and lines beneath it indicate flaws.

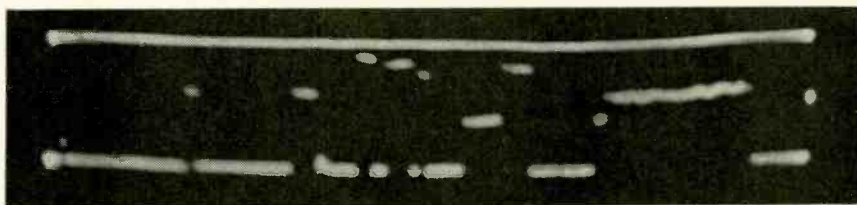

This instrument generates ultrasonic impulses by using radio-frequency current to vibrate a piezoelectric crystal (usually a quartz crystal, although barium titanate crystals have been used). Impulses with frequencies of 1 mc or more are commonly used, since echoes of maximum intensity cannot be produced with ultrasounds at lower frequencies. The exact frequency used in any given circumstance depends on the ability of a test material to pass a sonic impulse with maximum efficiency: no two different materials have the same acoustical properties.

The metal holder for the Reflectoscope's output crystal is usually held in close contact with the surface of a material to be inspected because high-frequency ultrasound will not penetrate the thinnest layer of air. However, the need for close contact between the crystal and a test specimen has been eliminated in many cases by immersing both units in a fluid such as water.

After the energy from each ultrasonic impulse is reflected, the output crystal of the Reflectoscope serves as a detector, making it possible to amplify

each echo and produce visual signals on the face of a C-R tube. The positions of the signals or visual images on the face of the tube vary with the amount of time required to produce different echoes.

Therefore, signals on the extreme right or left side of the tube indicate nothing more than the existence of two material surfaces; images near the center of the tube indicate internal flaws.

Devices of the Reflectoscope type have saved millions of dollars for railroads and airlines during recent years by locating small flaws in rails, axles, crankshafts and other components whose failure could cause serious accidents. Similar defects couldn't have been detected with X-rays in most cases because they were either too small to vary the density of X-ray pictures or they existed in materials such as lead and brass alloys which cannot be penetrated by X-rays.

Yet, for many industrial purposes, ultrasonic instruments had one serious shortcoming: They couldn't be used to distinguish small, unimportant flaws

Material immersed in tank is scanned, the image appearing on the C-R tube screen.

Components of search unit. Quartz crystal is mounted on right-hand end of long metal tube. Cone-shaped unit fits over tube and beams ultrasound. Remaining parts used to align tube and material.

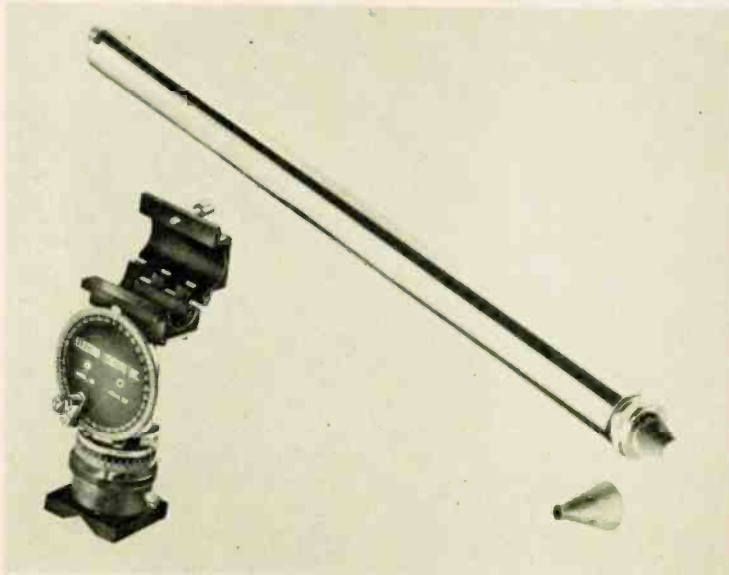
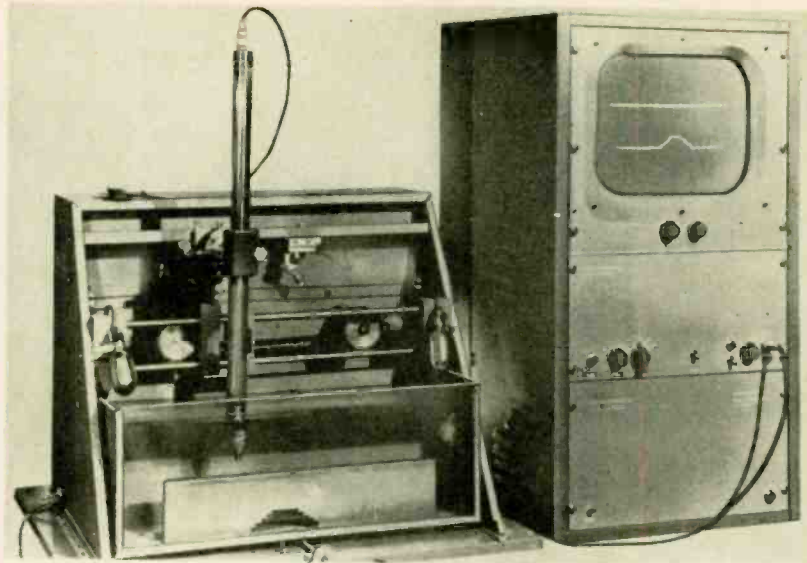

ing" is essential to the accurate evaluation of many flaws. For instance, an internal crack which appears to have pinpoint dimensions if it is viewed from one end may turn out to be a serious flaw when scanned from a different angle.

The images produced by rapid scanning may be either larger or smaller than the details of a specimen or area being tested, since their size can be controlled by a potentiometer mechanically coupled to the search unit.

Thus, if the potentiometer is properly adjusted, the cross-sectional details of a test specimen with a length of many feet can be compressed and viewed on a 16-inch screen. Or, the cross-sectional details of a very small specimen or limited test area can be magnified so that the most minute flaws can be easily observed.

Ultrasonic test methods will probably never replace X-ray testing techniques, since gamma radiations can be used to locate flaws in many materials with nonuniform composition—for example, in extremely porous castings and plastic laminates which would cause ultrasonic testing devices to produce a confusing variety of echoes and visual signals. However, ultrasonic techniques do appear to represent the least expensive and most effective means yet devised for the location of internal flaws in materials with uniform compositions.

It is worth noting that, while intense sound waves can be destructive, energy impulses that won't penetrate the thinnest layer of air create nothing remotely comparable to a radiation hazard. In fact, ultrasounds of the types used for test purposes have an established therapeutical value. And, according to recent report from researchers at the Massachusetts Institute of Technology and the University of Minnesota, they may soon be widely used to supplement X-rays for the accurate diagnosis of many internal diseases, including cancer types, which could not heretofore be identified without surgery. END

from the major defects which can cause some articles to be virtually useless.

This shortcoming has now been eliminated by a television type scanning technique that makes it possible to observe on a C-R tube a complete cross-sectional image of a test specimen—a view that could otherwise be obtained only if the specimen were cut into two pieces. This technique was originated by Electro-Circuits, Inc., Pasadena, Calif., but similar methods have recently been developed by other firms producing ultrasonic test instruments.

An ultrasonic search unit is moved over the surfaces of a material specimen so that as many as 1,000 energy impulses per second can be echoed, amplified and indicated on a C-R tube screen. A phosphor coating on the screen causes the visual signals to glow for many seconds after they are produced.

As a rule, both the output end of the search unit and the test specimen are immersed in a water-filled tank so that ultrasonic impulses and echoes can be transmitted and received without run-

ning the risk of damaging a thin quartz crystal by rubbing it over a rough-surfaced test specimen. Where an immersion tank is impractical, as in testing underground gas pipes for corrosion, special fixtures transmit the ultrasonic impulses to the surfaces of test specimens through a stream of running water.

As much as 90% of the energy transmitted by the search unit is echoed when it comes in contact with the nearest surface of the test specimen. This produces an intense reference line which indicates the relative position of that surface on the C-R tube screen.

Energy entering the test specimen is echoed either by flaws or the farthest surface, and the visual images produced on the screen indicate the precise shape and locations of flaws below the specimen surfaces.

Scanning movements of the ultrasonic search unit can be produced by either manual or mechanical means, and the position of the search unit can be varied to beam energy at a specimen from different angles. "Angular beam-

New techniques in

electroencephalography

the recording of
brain responses

By F. J. G. van den BOSCH

THREE years ago I suggested several new approaches to electroencephalograph (EEG) technique. One that I used with success in certain of my experiments is the beat-frequency technique—the circuit is shown in Fig. 1. It consists of the well-known Toennies input circuit, using a 6SC7 selected for low input noise and grid current. It is followed by a single 6SJ7, followed by a bridge system of the type used by Mr. Grey Walter. The output of the bridge is fed into the control grid of a pentagrid converter (a 6A8 has been found suitable). On grid 4 of this tube is injected the oscillator voltage.

The oscillator is a 6SN7-GT in a resistance-capacitance circuit. Its frequency can be varied by changing the value of C1, C2 and C3. I have found that the required frequencies (2 to 50 cycles) can be covered by using a variable capacitor for C2.

The oscillator tube is followed by a 6J5 buffer stage. The pentagrid stage is followed by a 6AK5 amplifier before being applied to the oscilloscope or a pen recorder. Wave analysis is very much simplified and can be made almost instantaneously if visual observation is sufficient; otherwise photographic records will show clearly in-phase signals as compared with other frequencies. I recommend this procedure strongly to anyone wanting to start in EEG. Compared with complicated wave-analysis apparatus, it simplifies matters very much and has enabled me to study the relative efficiency of different types of electrodes.

Let me remind the reader that these recordings (EEG) are made by applying to the scalp several small electrodes

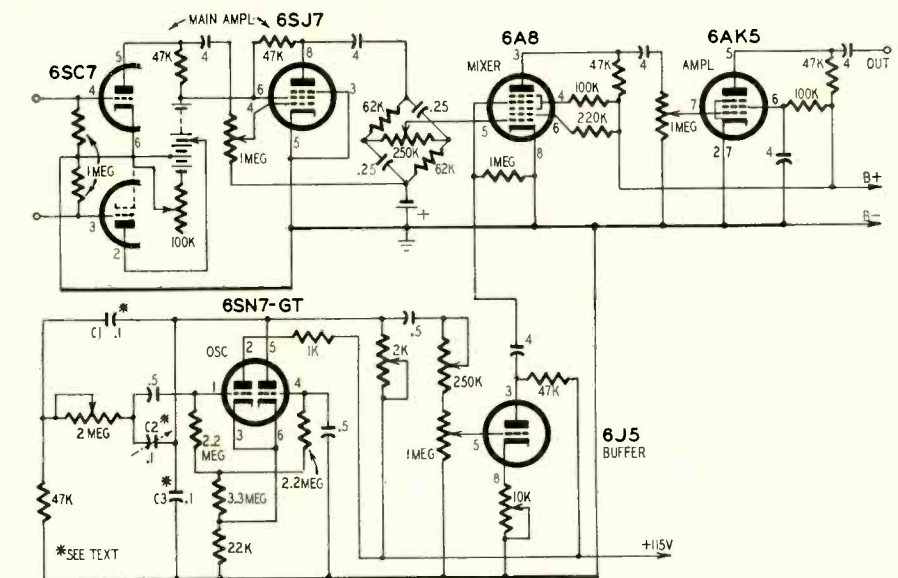

Fig. 1—Schematic of instrument used in beat-frequency technique experiments.

soaked in a saline solution. The potential difference between two electrodes is then recorded. The value of this potential can differ greatly, and practitioners have agreed on certain positions for the electrodes so that potential differences measured might be interpreted uniformly. The recordings have thus acquired a clinical significance. It has been possible to diagnose with certainty several diseases of the brain as well as identify and localize brain tumors.

EEG may still be considered in its infancy. Though it is proving of great assistance to the medical profession, it is—from the physicist's point of view—a very rudimentary method of ascertaining the electrical functioning of the brain.

Let us look at the input circuit. Fig. 2-a shows the method of applying electrodes to the head. Fig. 2-b is the equivalent circuit. Capacitors C1 and C2 are very small. Resistor R2 is the skin resistance between electrodes (they are in saline solution) and is usually between 5,000 and 15,000 ohms. When we consider the frequencies, the network is very inefficient. The electrodes applied to the head have a capacitance ranging from 1 to about 5 μf . This is of course an average, for the value varies from individual to individual and is governed by a series of factors outside the reach of either the physicist or neurologist (thickness of the skull, temperature of

the tissues, etc.). I have found variations from 2 to 6.2 in the dielectric constant. The virtual surface of the electrodes is also subject to slight variations. The same can be said of the resistance of R1, which is constituted by the neurons. But even with such an inefficient network, voltages averaging 50 microvolts are recorded.

The most commonly used system of recording EEG is by the potential gradient method, the voltages being recorded between two electrodes situated on the head. This is no doubt a very efficient and easy method for locating brain tumors. Another method of recording EEG potentials consists of taking the potential between one electrode on the head and one attached to an ear lobe as a reference electrode. I believe this method, when properly developed, should yield better results.

For some of these experiments I have used a double-tetrode electrometer tube manufactured in England by Ferranti (type DBM12A) as a separate preamplifier. Electronically speaking, it can better be considered as an impedance conversion device. The tube lends itself to the same applications as the American FP54, though this is a single tetrode. Fig. 3 shows this tube in the Dubridge-Brown circuit, which gives excellent results. Beginners should guard against temperature fluctuations which might influence readings. The circuit as shown together with the Ayrton shunt and galvanom-

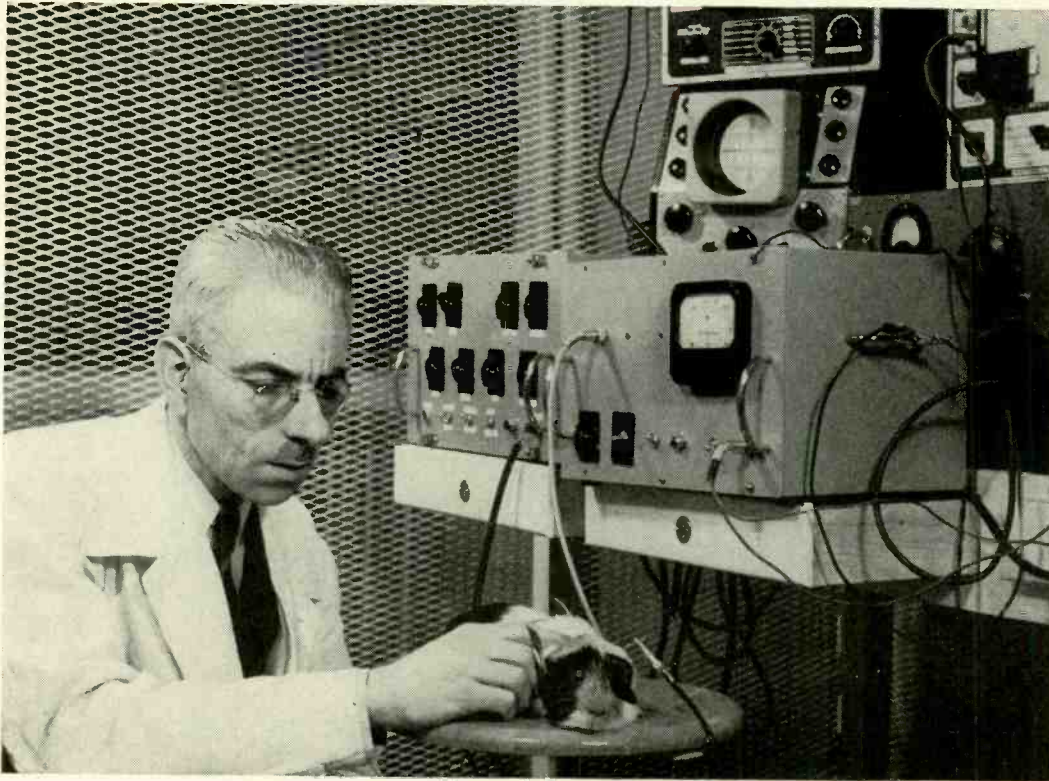

Author conducts an experiment in electroencephalography in his laboratory.

eter constitutes an excellent control apparatus. It is also recommended to physiologists who are interested in a single recording only.

Great progress has been made in the last few years in medical science in the anatomical, pathological, biochemical and surgical fields. What in my view has been left too far behind is the purely physical aspect. When a patient dies from an unknown cause, the anatomist may look to the pathologist to tell what happened. But cell structure alone (and these are *dead cells*) will not solve the riddle completely. I am sure that on the day when all the physical parameters are added to the normal medical diagnosis, medical science will really progress.

To enlarge the point a bit further, let us consider the human body a moment purely from the physical aspect. It can be considered a vast communications network with the brain as a kind of central and upper governor. Let us consider—for example—a pinprick in the hand: Immediately a train of pulses is sent to the brain, which interprets this message and sends out another train of pulses, apparently similar to the first, but with the result that there is an immediate withdrawal of the hand. If at the same moment the foot gets a comfortable feeling of warmth, the train of pulses will be interpreted differently.

Anatomists and neurologists tell us that the brain is a very complicated mechanism and that various centers deal with specific functions and that certain nerve fibers conduct only certain impulses. This does not take away the physical fact that the brain is able to detect, using the methods of frequency discrimination, pulse height and pulse modulation. That is, it is able to compare certain voltages and to

ascribe to those voltages specific functions, and in accordance with this, set in motion messages traveling along nerves, resulting in the control of muscles or glands.

If certain nerve fibers conduct only certain pulses, it is probably due entirely to the perfect matching networks these nerves possess to convey the particular messages. I suggest here that the modulation carried by nerve pulses most nearly approaches the coded-pulse type of modulation; a suitable oscilloscope display will show this. The average potential of such messages is in the order of several millivolts. This potential is produced by the central nervous system. When recording EEG with potentials of, say, 50 microvolts, a great loss must occur somewhere. In the interest of progress I hope someone will soon produce a new approach to the recording of EEG potentials, without having to use the corticoencephalographical method (recording direct from the exposed brain). Electronics is bound to find the correct answer to this problem in time. END

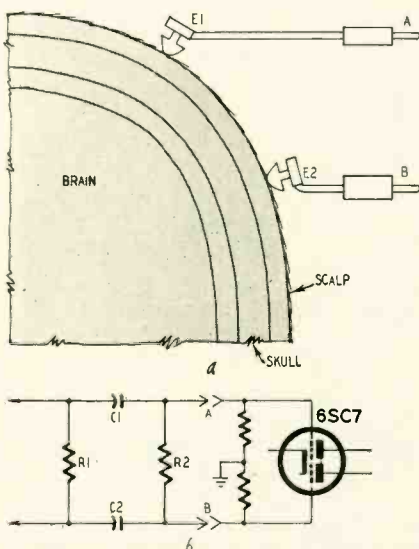

Fig. 2—Actual and equivalent circuits for applying electrodes to the head.

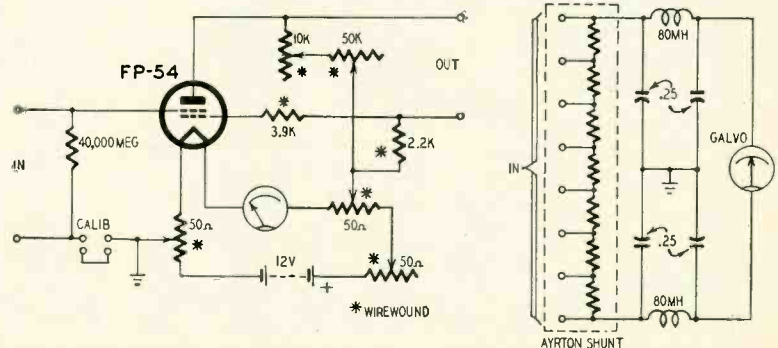

Fig. 3—The Dubridge-Brown circuit with the Ayrton shunt and galvanometer.

AIEE GOES ELECTRONIC

By FRED SHUNAMAN
Managing Editor

THE 1955 Winter General Meeting of the American Institute of Electrical Engineers—held in New York Jan. 31–Feb. 1—witnessed further advances of electronics into the field of electricity. Television was the subject of one of the sessions; others discussed semiconductors. Transistor time-delay circuits and transistor demodulators for magnetic amplifiers were among other subjects covered, as was a paper on calculating the voltage gain of a resonant dielectric amplifier.

One paper dealt with an all-magnetic audio amplifier system. The amplifier is powered with an a.c. supply at 10,800 cycles, permitting amplification of signals from 90 to 3,000 cycles. The supply is obtained from a three-phase, 400-cycle line by three cascaded frequency triplers. Power output is about 2.5 watts. The audio range could have been extended upward if desired by using a higher-frequency supply.

Two of the most important developments presented to the meeting were revealed by General Sarnoff of RCA in an introductory speech. These were an electronic tone synthesizer and an electronic cooler or refrigerator. The tone synthesizer was discussed in greater detail at a later session by Dr. Harry F. Olson, who developed it. General Sarnoff also referred to RCA's recent work in recording television programs and developing a light amplifier.

The tone synthesizer works on the

principle that a tone can be analyzed into its various characteristics: frequency or pitch, amplitude, attack or growth, duration, decay, waveform or timbre, frequency and amplitude modulation (vibrato and tremolo) and abruptness or gradualness of transition from one note to another. It is then possible to construct a device consisting of oscillators, filters, amplifiers and trees of relays which can reproduce any tone exactly, or produce tones like those of no presently known instrument.

The work of breaking a piece of music into its various components is slow and laborious. Once accomplished, however, the results can be placed on a perforated paper roll vaguely resembling that of an old-time player piano and reproduced as often as desired. One of the main uses of the instrument, according to Dr. Olsen, is to make phonograph records.

The electronic refrigerator is the work of Nils E. Lindenblad of the RCA Laboratories. Its principle is an old one—discovered by Peltier more than 120 years ago. When current is passed through the junction of certain dissimilar metals (such as copper and bismuth), the junction absorbs heat. For years attempts have been made to put the effect to practical use, but with little success. The RCA scientists point out that—unlike earlier workers—they had the advantage of new knowledge provided by recent studies in solid-state

physics. With new alloys they have been able to achieve usable temperature drops and feel that "our continuing quest for improved materials so far has discovered no indication that a limit has been reached."

Bell Laboratories presented a computer type device called the "outguesser." It utilizes a person's (or machine's) past performance to predict future actions. Limited at present to playing a game much like coin-matching, it may find practical applications in the development of future phone systems.

Another possibly more interesting, though less serious, device exhibited by Bell, was "Little Audrey," a machine that plays a version of the "take a number" game. The machine is intended to demonstrate what the telephone company can do with relays. Little Audrey understands three words, "yes," "no" and "O.K." spoken into a microphone, and communicates with the world by flashing words on a screen. The operator mentally selects a number from 1 to 8, then answers a number of questions asked by the machine, which always guesses the correct number. According to the scientists who developed it, Little Audrey can play the game with more finesse than any human player because she can hold a number of computations in her "memory" (composed of relays) that no human being could carry in his head. END

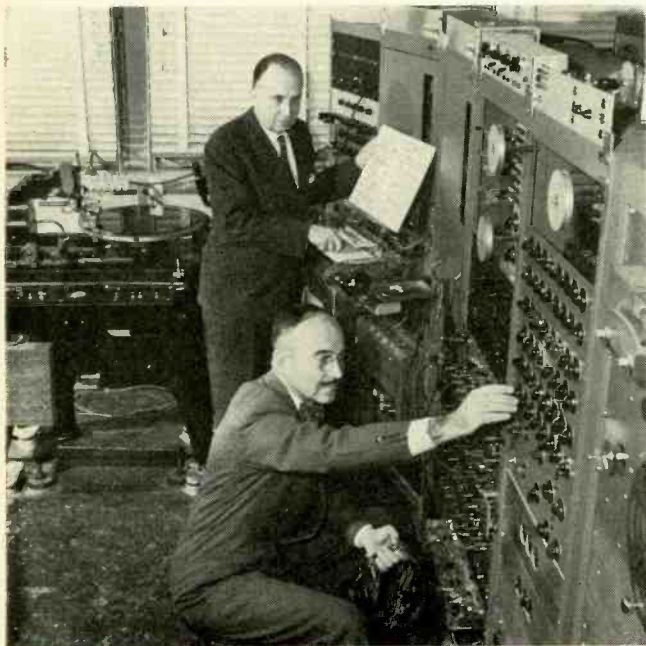

Tone synthesizer—Dr. Olson at keyboard, H. Belar at controls.

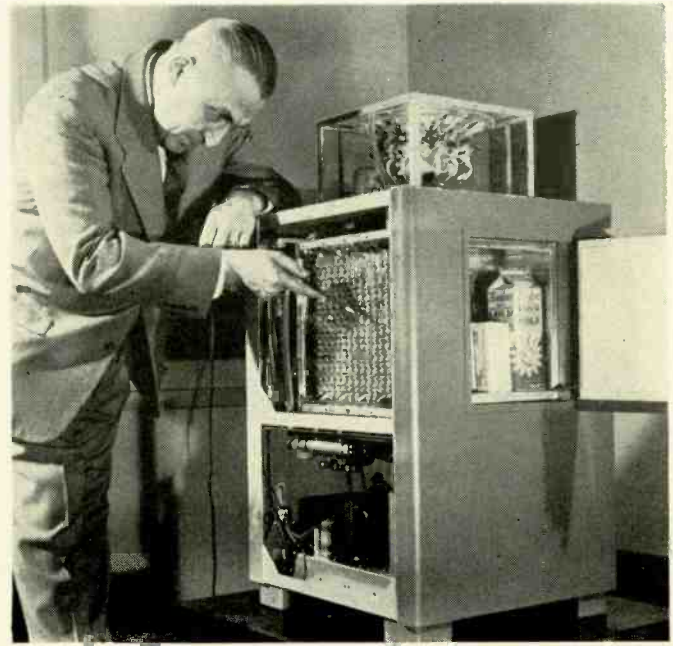

Nils Lindenblad shows Peltier elements in electronic cooler.

ABSTRACT OSCILLOGRAPHY

MORE than one technician has been fascinated by the patterns that can be obtained on his oscilloscope and has juggled the controls to bring in more interesting and intricate Lissajous figures. Some scope patterns have occasionally been printed for their beauty alone. It has remained for an Iowa experimenter to create a whole group of *Electronic Abstractions*, composed of sine, square and sawtooth waves, combined in various ways and with the help of phase splitters, amplifiers and distorting devices.

Mr. Ben Laposky of Cherokee, Iowa, is the electronic artist who produced the designs on this page as well as a multitude of others. Those shown here are among the simpler ones in his collection, which includes many remarkably delicate figures, numbers of striking three-dimensional effects, and some patterns very reminiscent of natural figures such as butterflies and ballet dancers.

More than 30 electronic instruments of various types, especially constructed or modified for the work, were used by Mr. Laposky to produce his collection of nearly 6,000 photographed designs. These *oscilloins*, or electronic art forms, have been exhibited in more than a dozen art galleries and museums throughout the United States. END

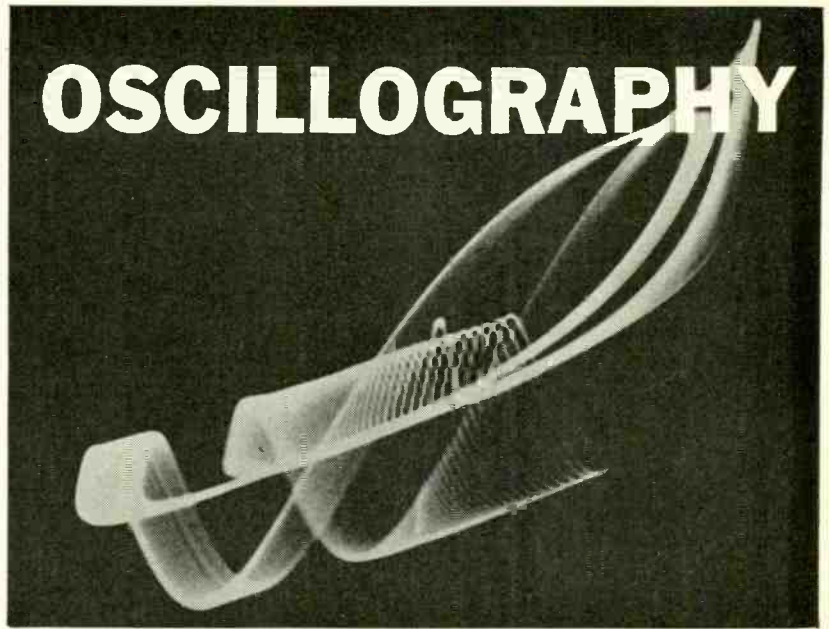

The above pattern was made by sine-wave generators connected to the H and V terminals through a phase-splitting network and another one connected directly across the H and V terminals.

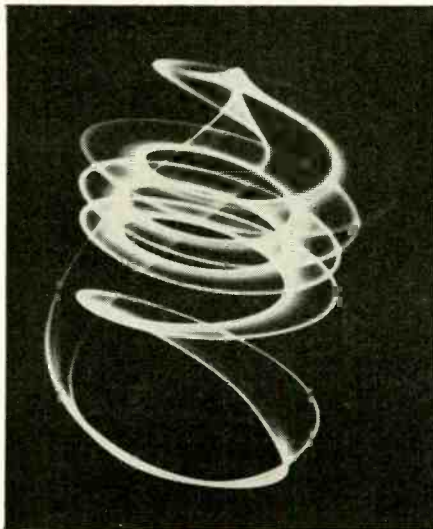

Sine-wave generator to scope through a phase-splitting network modulated by another across part of the phasing net.

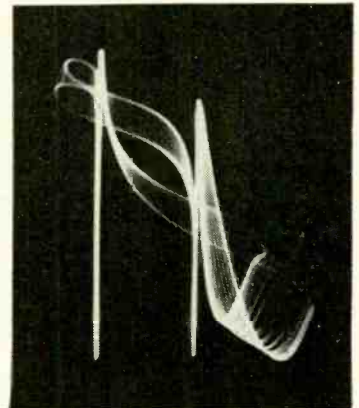

Two sine-wave generators, an electronic switch and a phasing network produced this pattern.

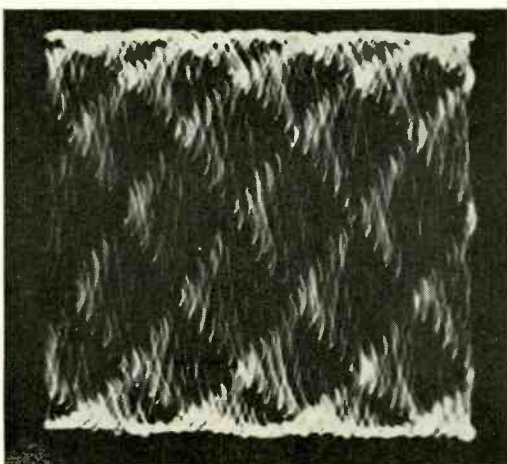

This is made by a sine wave to scope, with modulation by a sawtooth wave.

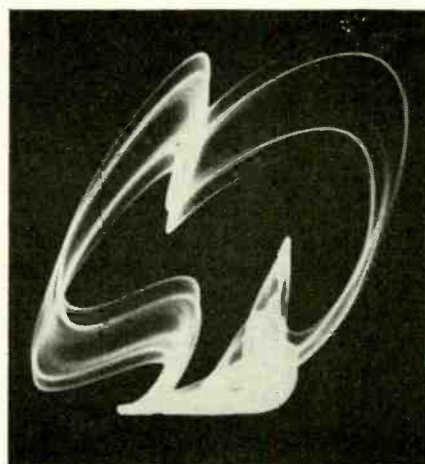

This is a sine wave through a circular amplifier, modulated by another sine wave.

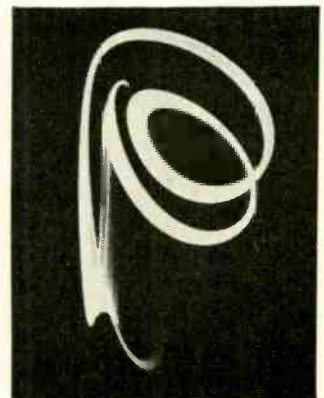

Two sawtooth generators in series through phase-splitting network.

Intercarrier

BUZ-Z-Z-Z-Z-Z-Z

*Various causes and cures
for this common trouble*

By ROBERT G. MIDDLETON*

THE intensity of 60-cycle sync buzz from the sound channel of an intercarrier receiver usually increases to a maximum when the picture and sound carriers are placed at equal heights on the response curve (Fig. 1). Incorrect placement of the carriers is usually caused by incorrect adjustment of the local oscillator, but may also be caused by incorrect alignment of the signal circuits at excessive bandwidth or mistuning of sound traps.

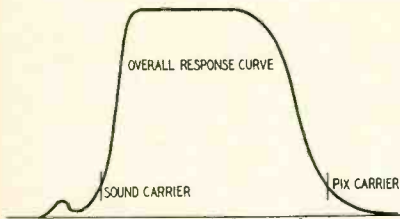

Fig. 1—Picture and sound carriers are incorrectly set at equal heights.

Even when the carriers are properly placed on the response curve, with the picture carrier at a point 6 db down from the top of the curve and the sound carrier 20 db down, nonlinear amplification of the TV signal causes cross-modulation of the picture and sound signals. This generates unwanted voltages, some of which are recognized as sync buzz in the sound.

A d.c. scope should be used to determine whether the residual picture carrier is being limited or clipped. It must be connected at the output of the picture detector if the video amplifier is a.c. coupled. If the video amplifier is d.c. coupled, the d.c. scope may be connected at the output of the video amplifier.

As shown in Fig. 2, the video signal rises above the zero-volt line on the d.c. scope screen, showing the amount of residual picture carrier present.

Except during test-pattern time, when the transmitter is being adjusted or during switching operations at the

transmitter, the maximum picture modulation is 85%, leaving a margin of 15% of unmodulated picture carrier present at all times to produce proper heterodyning of the sound and picture signals in the i.f. amplifier and picture detector, for developing a buzz-free 4.5-mc sound signal.

Nonlinearity in single-ended r.f. amplifiers almost invariably produces sync-pulse compression (Fig. 3) without affecting the residual picture carrier. However, double-ended r.f. amplifiers in distribution systems and similar arrangements will occasionally develop residual carrier compression. The presence of this distortion can be checked easily with a d.c. scope.

The appearance of sync buzz in the sound (Fig. 4) when the video signal is completely unaffected and only the sync tips are clipped or compressed may seem strange. But, when a sync tip is clipped, the video carrier is being clipped. During the clipping interval cross-modulation of the sound signal and picture carrier takes place, generating harmonics and sum-and-difference frequencies. The difference frequencies are heard as 60-cycle sync buzz in the sound channel.

Nonlinearity in the r.f. and i.f. am-

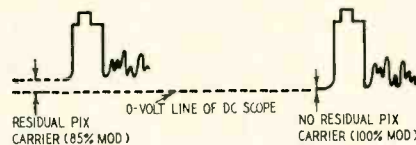

Fig. 2—Video pattern on d.c. scope.

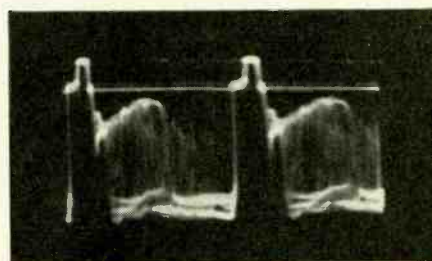

Fig. 3—Sync-tip compression pattern.

plifiers is usually caused by low a.g.c. voltage, permitting grids to be overdriven. However, other incorrect operating voltages, such as low plate and screen voltages, can cause nonlinear operation even when the grid bias is correct. Likewise, a weak tube can cause this type of sync buzz.

When the signal levels on various active channels differ widely, buzz may be heard when receiving a strong signal but disappear when receiving a weak one. Likewise, picture distortion may

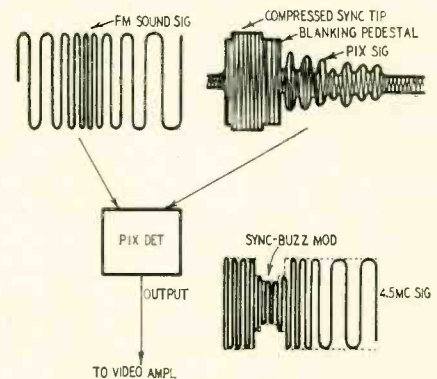

Fig. 4—Producing sync-buzz modulation.

accompany the sync buzz when a strong signal is being received but disappear on a weak signal, because the nonlinearity of a stage is usually reduced when the grid drive is reduced. In some cases the buzz level becomes annoying only when a weak signal is being received. One of the reasons for this is that many intercarrier receivers have a partial limiter ahead of the ratio detector, and limiting action falls off as the signal level is reduced. There is always some buzz modulation in the 4.5-mc sound signal, often sufficient to be audible unless good limiting action is provided ahead of the ratio detector.

Another reason for buzz increase on weak-signal reception is unbalance in ratio-detector operation—the center frequency of the ratio detector shifts with changing signal level. This un-

* Field Engineer, Simpson Electric Co.

balance can be seen easily with the aid of a sweep generator and marker. As the output from the sweep generator is reduced, the S curve should decrease symmetrically in height and the 4.5-mc marker should remain exactly at the center point of the S curve. Unbalance in ratio detectors is a major problem. Some of the more common causes are: unbalance in the duo-diode tube, defective stabilizing capacitor (single-ended circuits), out-of-tolerance bleeder resistors and ratio capacitors.

In still other cases the signal circuits regenerate at low bias values, causing serious deterioration of both i.f. and ratio-detector response curves during weak-signal reception. Regeneration is an involved problem. However, systematic tests are available for regenerative signal tracing and provide localization of the feedback loop. A feedback loop is always present when regenerative distortion exists. Once the loop is traced out, the search for the fault is narrowed down considerably.

Probes for troubleshooting

Suitable probes must be used with a d.c. scope when checking the 4.5-mc sound signal and when checking amplifiers for shift of the operating point. Two arrangements are shown in Fig. 5.

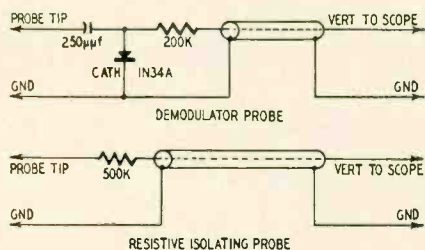

Fig. 5—Probes for checking sync buzz.

The crystal demodulator probe is especially interesting. The output of the demodulator probe has an a.c. and a d.c. component, as shown in Fig. 6. When a demodulator probe is applied in the 4.5-mc signal circuits, the display rises above the zero-volt level by an amount equal to the voltage of the FM sound signal.

The top of the FM sound signal, as seen in Fig. 6, is not uniform, but contains AM components generated by cross-modulation and by slope detection. Chief of these, from the standpoint of buzz troubleshooting, are the 60-cycle buzz pulses, usually appearing as a downward notch in the 4.5-mc signal, as shown. This notch is the stripped vertical sync pulse. Stripping results from passage through narrow-band circuits—in particular, from passage through the demodulator probe output network. When the buzz voltage is higher, the notching is deeper, as shown in Fig. 7. Using the zero-volt level on the screen of the d.c. scope as reference, the percentage of modulation of the 4.5-mc sound signal by the 60-cycle buzz pulse can be found.

A conventional ratio detector can

reject about 40% of downward modulation, but higher percentages ride through the ratio-detector circuits and appear in the sound output. Hence, the modulation must be kept below 40% or a limiter must be used ahead of the ratio detector.

The resistive isolating probe (Fig. 5) is useful for checking for shift in

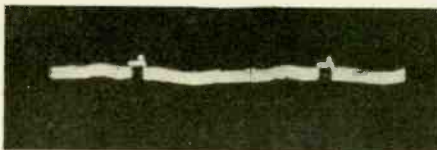

Fig. 6—The demodulator probe output.

operating point. It is used with a d.c. scope and can be applied at the plate of any tube in the signal circuits. The test is made by observing the level of the trace on the scope screen with the antenna connected, and then disconnected, from the receiver. Any shift in the level of the trace indicates a shift of operating point in the amplifier tube; hence nonlinear operation which increases the amount of buzz modulation in the 4.5-mc sound signal.

Lead-in mismatch buzz

Buzz is sometimes the result of an impedance mismatch between the lead-in and the front end of the receiver. This occurs because the impedance mismatch generates standing waves on the lead-in. These offer a different impedance to the front end at different frequencies, which distorts the response of the receiving system. As a result of this distortion, the sound-carrier voltage may be boosted, while the pic-



Fig. 7—Deeply notched sound signal.

ture-carrier voltage is attenuated. The heterodyning process through the picture detector then takes place at improper voltage levels and the 4.5-mc beat contains an abnormal amount of vertical-sync modulation.

Discontinuities of the lead-in cause similar trouble. Discontinuities are caused by taping the lead-in to metal pipes, draping the line over metal gutters and running the line under metal window sashes. Mismatch buzz varies in intensity from channel to channel and usually can be heard on only one or two channels; alignment buzz, in most cases, is apparent on all channels.

When the front end is mismatched to the lead-in, various corrective measures are possible. The input impedance of the front end is controlled primarily by the closeness or looseness of coupling of the r.f. grid coil to the antenna coil on the tuner strip. Although such adjustments require knowledge of how to use the scope to determine impedance matches and mismatches, the operation is no more difficult than that of tuned-circuit alignment. It is only the unfamiliarity of impedance adjustment which makes it look hard.

Detailed discussion of these matters will appear in an early issue. END

TELEVISION MASTS OVER RUSSIA



Marquerite Higgins

TV antennas on an apartment house in Zagorsk, 40 miles from Moscow. TV reception in Russia is concentrated in areas within 100 miles of a few large cities.

HORN ANTENNA *construction*

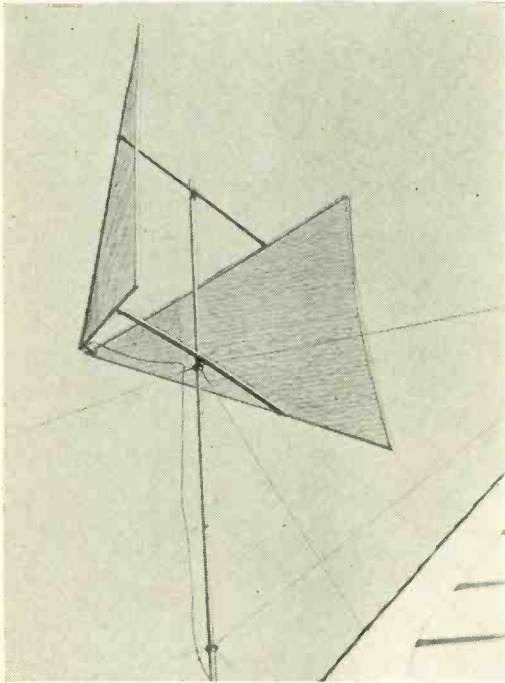

By M. G. O'LEARY

*Unit provides
excellent
u.h.f.—v.h.f.
fringe-area
reception*

AM radio had its advantages. Ordinary wire 20 to 30 feet long would bring in more than enough stations from any direction. In fringe areas TV reception is much more complicated. Aside from boosters, u.h.f. converters, local-fringe switches, etc., the choice of a proper antenna installation is often complex. For example, in Kingston, Ont., one might like to receive:

Channel	Location	Direction	Distance (miles)
9	Toronto	W	150
4	Buffalo	WSW	150
6	Rochester	SW	85
10	Rochester	SW	85
3	Syracuse	S	75
8	Syracuse	S	75

The average family up here beams a couple of Yagis or a broad-band antenna at Syracuse and settles for channels 3 (100 kw) and 8 (200 kw). With this arrangement channel 3 comes in well, channel 8 not as well, despite its extra power. This indicates that it is more difficult to pull in the high-band than the low-band v.h.f. stations in fringe areas. The problem was still more complicated due to our home being in a valley.

What we needed was an antenna reasonably sensitive on the low band, very sensitive on the high band and extremely sensitive for u.h.f. stations. Because of children in the family, we wanted one lead-in. Channel 48 (soon to go on the air) would be tuned by a u.h.f. strip in the turret tuner. At the present stage of the art antenna sensitivity is directly related to directivity—sensitive antennas must be rotated

for optimum reception from different directions. I tried to get around this by designing a long-wire type of antenna that, in one position, would be correctly oriented for most or all of the stations listed above. It wouldn't work. I turned to studying the various types of broad-band v.h.f.—u.h.f. antennas.

I couldn't find any antennas that met the sensitivity requirements for u.h.f. as well as v.h.f. However, I did find a technical article describing a type that seemed to do what was needed—an article on horn antennas by Dean O. Morgan in the October, 1951, issue of *Electronics*. This antenna was based on that article. It must be rotated for stations in different directions, but it meets my rather exacting demands in all other respects. We have not had any u.h.f. yet, but are confident that the antenna will pull in channel 48 when it comes.

Antenna design

The "horn" is the shape of a pyramid laid on its side with the top and bottom sides left open (see photo). The two other sides are electrically isolated and feed the transmission line at the apex. All angles are 60°—the sides are equilateral triangles and are flared at 60° from each other. These sides could be built in a number of ways, but it seems most practical to use chicken wire for lightness and low wind resistance.

The sensitivity of the antenna is a function of its mouth size with respect to the wavelength to be received—greater sensitivity for larger size.

Gain is directly proportional to direction, and this holds true in practice. On the high band the antenna must be beamed very accurately; on the low band the beaming can be fairly sloppy. Syracuse and Buffalo are some 60–70° apart, yet channel 4 in Buffalo will come in relatively well when the horn is beamed at Syracuse. As a matter of fact, there is a suspicion in my mind that, for channel 3, the antenna just approaches being a huge dipole, as airplane flutter occurs when planes fly to the rear of it. Nevertheless, the picture-pulling power for channels 3 and 4 seems to compare well with other types of fringe antennas.

With a rising-gain-rising-frequency characteristic, one would expect tremendous sensitivity at channel 48. Such would not be desirable in practice, for the tremendous gain would be accompanied by pinpoint directivity. Even if the antenna could be pointed accurately, it could not be held on the beam constantly for such a large structure is sensitive to even the very lightest breeze. Fortunately, there is a simple means of holding down u.h.f. sensitivity to a practical value.

If the mesh spacing of the chicken wire exceeds .05 wavelength, there is loss of sensitivity. At 200 mc, .05 wavelength is approximately 3 inches. At 600 mc, it is 1 inch. The use of 2-inch mesh wire for the antenna with a 36-inch wide strip of 1-inch mesh at the apex should have the effect of an electrical mouth size of 3½–4 feet at 600 mc. This should allow the directivity at channel 48 to be less critical.

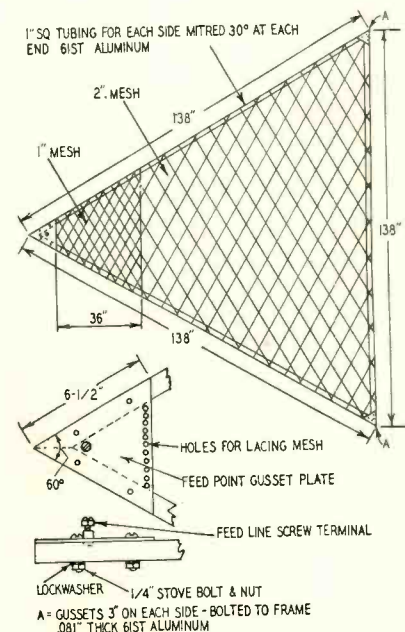

Fig. 1—The sides of the horn antenna.

Some months after his article was published Mr. Morgan wrote in *Electronics* in reply to letters written him by experimenters who had built the horn. Most of these reported excellent results electrically. Mechanically, results were poorer—it was hard to keep the antenna in the air.

You can't appreciate the size of an 11½-foot horn antenna until it is erected. Mine has become almost a landmark. When first put up 6 months ago, it was not only a curiosity, but also the butt of many nasty predictions of what would happen come the first blow. I freely admit that despite the thought given to this weakness—the large wind resistance—and the steps taken to offset it, many nervous hours were spent when the weather acted up. Apprehension has now ended; a local newspaper reported the sad ending of a great many TV antennas as a result of "one of the worst sleet-and-wind storms in years." Our horn weathered it unscathed.

Success in keeping this antenna up is probably due to sturdy construction of the antenna, reinforcing the mast above the topmost guy support, and heavy guy wires at not too great an angle from the horizontal (see construction diagrams).

Antenna construction

Construction details on the horn antenna are given in Figs. 1, 2 and 3 and the method of mounting is shown in Fig. 4. Each side of the antenna (Fig. 1) is first covered by butting and lacing together pieces of 72 inch wide 2-inch chicken wire and then lacing it to the frame. Next, the 1-inch mesh is cut to size from a 36-inch width and then woven or laced to the frame and apex (feed-point) gusset.

The sides of the horn are 1 inch apart at the apex. This distance is maintained by a hardwood spacer bolted to the apex gussets as shown in Fig. 2. The 60° angle between the sides is maintained by two hardwood cross-arms cut as in Fig. 4.

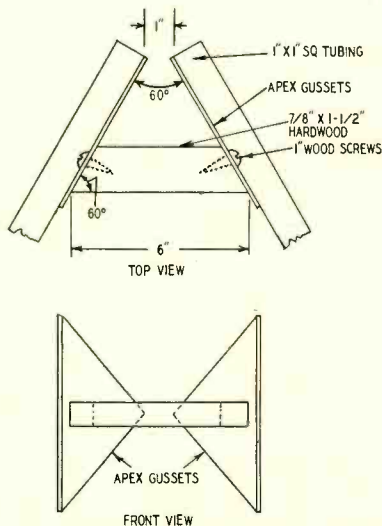

Fig. 2—The hardwood apex support.

The mast is 42 feet high and made of three tubes: the bottom section is a 25-foot length of slightly oversize 1½-inch pipe into which is telescoped a 20-foot length of 1¼-inch pipe for a distance of 3 feet. The third tube, a 12-foot length of 1-inch pipe, is telescoped almost completely into the top of the 1¼-inch pipe, to reinforce the 1¼-inch pipe at and above the top guy support. This third tube paid dividends. A survey of the damage caused by the recent storm revealed that many steel masts snapped off like matchsticks just above the topmost guy support. Most of the other damage involved failure of one of the top guy wires, permitting the wind to bend and twist the mast, steel or aluminum alloy like licorice. My mast was 61ST aluminum alloy.

The mast was supported at the 12-, 25- and 34-foot levels. The two top supports are each guyed with three wires—galvanized clothes line was used, stranded double for each of the top guys. I became very fussy about anchoring the guy wires after a tensile test revealed that the usual casual type of twisting would slip loose easily. The two guy-wire rings are ¼ inch thick, and the edges of the holes for the wires are rounded and smoothed to prevent the wires from being cut through.

Raising the mast is difficult, somewhat like fastening a brick to the business end of a buggy whip and standing it straight up with the brick topmost. Four or five assistants, plenty of extra length on the guy wires, lots of patience and an absence of wind simplify the operation.

Some comments on the material specifications may be appropriate. Square tubing is used because it makes it much easier to "square up" the structure. Fairly thin-walled tubing is not only satisfactory but desirable for lightness. As a substitute, 24ST alloy may be used. Alloy angles of 14ST or 24ST may be used, and any hard-rolled temper of 3S, 4S, 52S or 24ST should serve as a satisfactory substitute for the 61ST used for the gusset plates. Corrosion engineers will deplore the use of steel bolts in direct contact with the aluminum alloys. If aluminum-alloy,

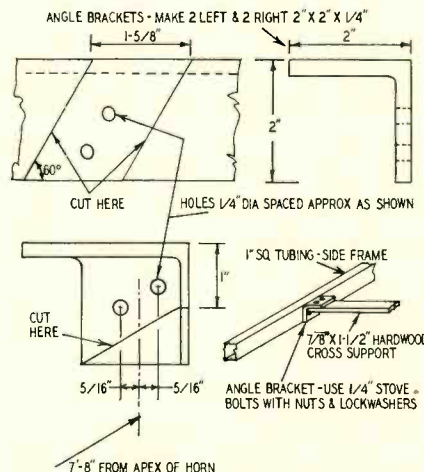

Fig. 3—Mounting the angle brackets.

cadmium-plated or galvanized fasteners can be obtained, they should be used. If not, the use of steel should not shorten the life of the structure too much—it will probably last for years.

I did not specify the type of hardwood because I forget what it is. I told the lumber dealer what it was wanted for, and he supplied a straight-grained, knotfree variety.

Antenna performance

Comparisons must be qualitative rather than quantitative as I do not have a field-strength meter. Before moving, we lived in one of the higher-altitude districts of Kingston, Ontario. Using a 10-element Yagi cut for the high v.h.f. band, we pulled in channel 8 as well as or better than our immediate neighbors who had assorted types of antennas. We then moved to a low-lying area. From Syracuse, we were immediately behind a 50-foot hill covered with high trees and houses. Here, channel 8 was rather poorly received on the Yagi. When the horn antenna was erected there was a noticeable improvement.

During January and February reception here is at its worst. In these months we generally had a snowy, but intelligible, picture on channel 8, and an almost snowfree picture on channel 3. Besides Syracuse stations, channel 4 in Buffalo is frequently received, sometimes with excellent quality. Also, many programs have been enjoyed from Toronto and Rochester stations.

For those who have not seen Mr. Morgan's article, the feed-point impedance of the horn antenna is 375 to 400 ohms from the low v.h.f. band to the u.h.f. range. This is not too much of a mismatch for 300-ohm line—and possibly as good a match as many other broad-band types of antennas.

Some may point out that no means of rotating the antenna can be seen in the photo. There is a mechanical lever at the base of the mast. But there is no reason why a standard type of rotator cannot be used, provided that it is arranged so that the mast is given support above the rotator. END

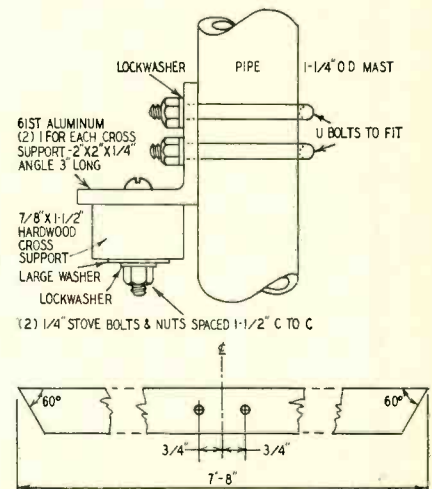

Fig. 4—The hardwood cross-supports.



CONSIDERING the fact that the picture tube is the most expensive component of a TV receiver, surprisingly little attention is given to the selection and adjustment of the ion-trap magnet, a unit that can so materially affect the life of the tube. An improperly installed magnet robs the viewer of optimum performance and can severely damage the picture tube. The adjustment of the ion-trap magnet should not be haphazard—there is a technique.

The picture tube having an imperfect "vacuum" contains small amounts of gas molecules. Some of these "capture" free electrons and become negatively charged ions, taking their place in the tube's beam current along with other ions emitted from the surface of the cathode.

Because of their enormous weight as compared to that of the electron, the ions are only very slightly deflected by the vertical and horizontal magnetic fields. Thus, unless precautions are taken, the inertia of the gargantuan ions would send them crashing into the center of the picture tube, contaminating the screen phosphor and eventually producing a darkened center area called an ion spot. (See "Ion Burns" in the February, 1952, issue.) This deactivated area of the screen surface cannot be repaired. Picture tubes using low-voltage electrostatic focusing are especially prone to ion-spot damage.

Two methods are commonly used to prevent ion spots, both based on preventing ions from reaching the screen.

Bent-gun ion trap

In this system (Fig. 1) the cathode, control grid and accelerating anode are bent at an angle with respect to the rest of the gun so that the beam current (containing both ions and elec-

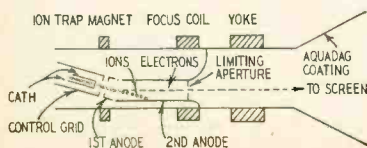
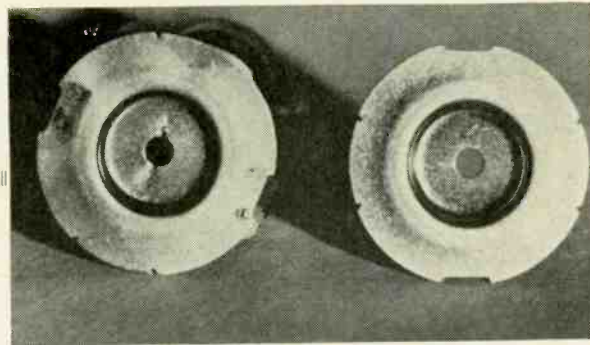

Fig. 1—Bent- or tilted-gun ion trap.



Allen B. Du Mont Labs.

Anode-limiting aperture at left damaged by misalignment of electron beam. Disc at right is undamaged.

trons), if allowed to flow in a straight line, would strike the side of the second anode and never reach the screen. By placing a magnetic field across the path of the beam current it is possible to direct the electrons toward the screen. However, the heavier ions are not affected by the magnetic field and are attracted to the second anode.

The bend in the gun structure is called the ion trap, and the external magnet that separates the electrons from the ions is called the ion-trap magnet or beam bender. Most TV receivers use a single permanent magnet. A few use a coil or electromagnetic type, supplied from a d.c. source in the set.

Slashed-field ion trap

A second type of ion trap (Fig. 2) uses an electrostatic field to deflect the beam current from the axis of the pic-

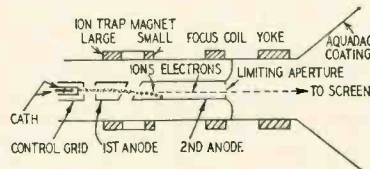

Fig. 2—Slashed-gun type of ion trap.

ture tube. The first and second anodes have a diagonal gap between them, with the first anode at a low voltage (approximately B plus) and the second at a high voltage. This produces a warped electrostatic field between the anodes. This field deflects beam current toward the second anode. (Ions are easily deflected by electrostatic fields. Thus, C-R tubes using electrostatic deflection need no ion-trap magnets. The ions are not concentrated, but swept over the face of the tube.)

In this gun structure a double ion-trap magnet is used to set up the magnetic field in the path of the beam current. This field deflects the electrons toward the screen, leaving the undeflected ions trapped on the inner surface of the second anode.

The diagonal-cut (slashed) gun has a pair of internal pole pieces, called flags, attached to the gun structure.

They direct and concentrate the magnet field and are an important guide in adjusting the ion-trap magnet.

Ion-trap magnet

The beam bender supplies a steady magnetic field with lines of force at right angles to the beam axis. When properly positioned, the magnet deflects the electron stream through the center of the limiting aperture at the front end of the second anode. Most picture tubes, having second anode voltages of from 10 to 16 kv, require magnets having a field strength of from 30 to 50 gauss.

Ion-trap magnets are usually of the permanent-magnet type and almost always made of Alnico. When a double-magnet type is used, the stronger of the two should be toward the base of the picture tube. Most tube manuals indicate whether a single or double magnet should be used.

Adjusting the ion-trap magnet

For maximum picture-tube life the ion-trap magnet should be adjusted at the time of installation in the home, after any movement of the picture tube and after any adjustment of the focus coil. Before making any adjustments be sure the deflection yoke is centered on the neck of the picture tube and pressed firmly against the flare of the tube.

With the set in operation, turn the contrast control completely counterclockwise and the brightness control to a low level until after the initial adjustment of the ion-trap magnet. This should be made immediately after the receiver is turned on. Keeping the brightness low is very important—picture tubes have been completely ruined in less than 30 seconds because of an ion-trap magnet being misadjusted while the beam current was high.

If the ion-trap magnet is incorrectly positioned, the electron stream strikes the edge of the hole in the accelerating anode instead of moving smoothly through it. The heat created by this contact can vaporize the disc metal, making proper focusing impossible and

NEW 1955

Heathkit

Engineering Features

New PRINTED CIRCUITS

One of the many tremendous improvements in the new 1955 Heathkits is the use of an etched metal process printed circuit board. Printed circuits will be used in Heathkits whenever they will affect construction simplification, performance stabilization, and lend themselves to instrument design. Now for the first time a kit instrument company offers the advantages of modern printed circuit instrument construction technique. For the first time consideration has been given toward reducing kit assembly time. Also this is the first time that printed circuit boards have been hand soldered on a volume basis. Offered only by Heathkit, the pioneer and leader in kit instrument design.

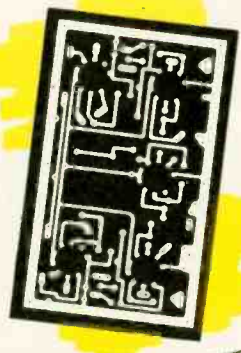

New PEAK-TO-PEAK VTVM CIRCUIT

New 6AL5 full wave rectifier in AC input circuit permits full scale peak-to-peak measurements. Seven ranges — upper limits 4000 volts peak-to-peak. Just the thing you TV servicemen have needed in making TV circuit voltage checks. Precision resistor voltage divider limits AC RMS level to 150 volts. Prevents overloading the rectifier — extends upper limit AC RMS ranges to 1500 volts RMS ranges to 1500 volts RMS further protects meter and circuitry against AC flash-over or arcing. Another definite example of continuing Heathkit design leadership in the kit instrument field.

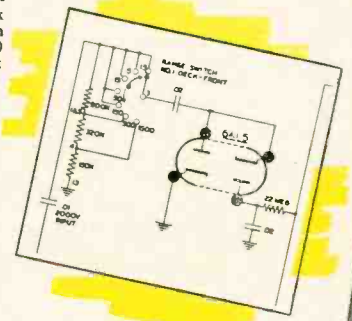

New HIGH READABILITY PANELS

New 1955 Heathkits feature complete panel redesign. Sharp white lettering applied to the beautiful charcoal gray panels, provide a new high in readability. Lettering is easy-to-read open style and panel calibrations are vividly clear against the pleasing soft gray background. New knobs of exclusive Heathkit design.



New 3" UTILITY SCOPE

The new 3" Scope is a "natural" for the well rounded line of Heathkit instruments. Small in size, 11 1/4" deep, 6 1/2" wide, 9 1/2" high, yet big in performance. Just think of the value, an Oscilloscope for \$29.50. Brilliant intensity, sharp focusing, wide positioning range. An ideal portable Scope for the TV serviceman — a second shop scope — modulation monitor for you hams (deflection plate terminals in rear of cabinet). Performance to spare for all general scope applications. See specifications on following page.



New STYLING New COLOR

New styling and coloring is responsible for tremendous improvement in Heathkit appearance. The new instrument panel color combination is high definition white lettering in a soft charcoal gray panel. Cabinet color is a lighter leather gray. The satin gold baked enamel cabinet for the WA-P2 Preamplifier is further indicative of the modern pacesetter trend in Heathkit styling.



New SCOPE SWEEP CIRCUIT 10 CYCLES — 500 KC

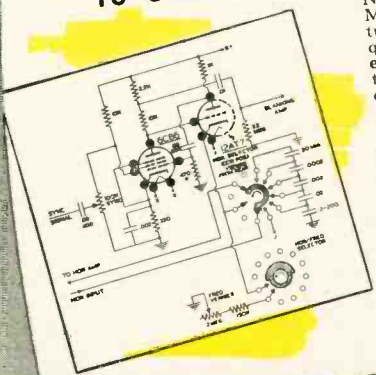

New 1955 Heathkit Model 0-10 Scope features a new wide frequency range sweep generator covering 10 cycles to 500,000 cycles. This coverage is available in five virtually decade frequency ranges and is five times greater than the sweep frequency range usually available. Excellent retrace time characteristics, actually less than 20% at 500 KC. Use of the free running Heath circuit provides a larger margin of stability and a new high in Heathkit Scope performance.

Continuing PROGRESS FUTURE LINE EXPANSION



The outstanding improvements featured in the 1955 Heathkit line are representative of the progress characterized by the Heath Company operation. Long range planning will provide a continuing succession of new kit releases to further expand the Heathkit line which already represents the world's greatest selection of electronic kits. The innovations in the 1955 line, are representative of additional new models scheduled for release for the coming years.

SEE THE INSTRUMENTS ON THE FOLLOWING PAGES

HEATH COMPANY • • Benton Harbor 20, Mich.

Heathkit ELECTRONIC SWITCH KIT

The basic function of the Heathkit Electronic Switch Kit is to permit simultaneous oscilloscope observation of two separate traces which can be either separated or superimposed for individual study. This is accomplished through the use of two individually controlled inputs working through amplifier, multi-vibrator, and blocking stages. The output of the Electronic Switch is connected directly to the vertical input of the Oscilloscope. A typical example of usefulness would be simultaneous observation of a signal or waveform as it appears at both the input and output stages of an amplifier.

APPLICATIONS

An Electronic Switch has many applications to increase the over-all operating versatility of your oscilloscope. It can be used to check amplifier distortion—audio crossover networks—phase inverter circuits—to measure phase shift—special waveform study, etc. The instrument can also be conveniently used as a square wave generator over the range of switching frequencies, often providing the necessary wave form response information without incurring the expense of an additional instrument. Ownership of this instrument will reveal many entirely new fields of oscilloscope application and will quickly justify the modest cost of the Electronic Switch Kit.

Individual input gain controls, position control, coarse frequency control, and fine frequency control.

Transformer operated for safety when used in conjunction with other equipment.

Tube complement: 2-6X4, 2-6SN7, 1-6X5.

Continuously variable switching rates in three ranges from less than 10 CPS to over 2000 CPS.



MODEL S-2

\$23.50

Shpg. Wt.
8 lbs.

Heathkit VOLTAGE CALIBRATOR KIT



MODEL VC-2

\$11.50

Shpg. Wt. 4 lbs.

Another useful oscilloscope accessory particularly in circuit development work and in TV and radio service work. The Voltage Calibrator provides a convenient method for making peak-to-peak voltage measurements with an oscilloscope, by establishing a relationship on a comparison basis between the amplitude of an unknown wave shape and a known output of the voltage calibrator. Peak-to-peak voltage values are read directly from a calibrated panel scale without recourse to involved calculations.

FEATURES:

To off-set line voltage supply irregularities, the instrument features a voltage regulator tube. A convenient "signal" position on the panel switch by-passes the calibrator completely and the signal is applied through the oscilloscope vertical input, thereby eliminating the necessity for constantly transferring test leads.

RANGES:

With the Heathkit Voltage Calibrator it is possible to measure all types of complex waveforms within a voltage range of .01 to 100 volts peak-to-peak. Build this instrument in a few hours and enjoy the added benefits offered only through combination use of test equipment.

Heathkit LOW CAPACITY PROBE KIT



No. 342

\$3.50

Shpg. Wt. 1 lb.

An oscilloscope accessory, the 342 Low Capacity Probe permits observation of complex TV waveforms without distortion. An adjustable trimmer provides proper matching to any conventional scope input circuit. Excellent for high frequency, high impedance, or broad bandwidth circuits. The attenuation ratio can be varied to meet individual requirements.

Heathkit SCOPE DEMODULATOR PROBE KIT



No. 337-C

\$3.50

Shpg. Wt. 1 lb.

Extend the usefulness of your oscilloscope by observing modulation envelopes of RF or IF carriers found in TV and radio receivers. The Heathkit Demodulator Probe will be helpful in alignment work, as a gain analyzer and a signal tracer. Easy construction with the new modern printed circuit board. Voltage limits are 30 volts RMS and 500 volts D.C.

TELEVISION

releasing gas that is extremely harmful to the tube. The vaporized material is usually carried along and deposited on the screen of the tube, appearing as a dark spot. Thus, the lower the beam current during adjustment, the less the possibility of damage. In large-screen tubes the problem is more serious because of the higher voltages which hasten the damage.

Place the ion-trap magnet on the neck of the tube, directly over the slash or bend in the gun structure. If the flags can be seen, use them as a guide. Move the magnet forward and backward, at the same time rotating it slightly in both directions until maximum screen brightness is obtained.

The ion-trap magnet is basically a beam-centering device. However, it is not the only unit that affects beam centering. Thus, best centering is indicated by maximum brightness. There are often two positions of maximum brightness—use the one nearest the base of the picture tube. The second maximum is caused by the ion-trap magnet being too close to the focus coil or magnet. The interaction of the two fields causes a maximum brightness in the wrong position, one that can damage the electron gun. If in making the adjustment the magnet has to be moved more than ½ inch from the starting point, the magnet is probably weak and should be replaced.

Bring the screen brightness up to normal and again adjust the ion-trap magnet for maximum brightness. At this point adjust the focus control to obtain a clear line structure on the raster. Then make a final adjustment of the ion-trap magnet for maximum brightness, with the brightness control set to the maximum position with which good line focus can be maintained.

If corner shadows appear after the ion-trap magnet has been adjusted for maximum brightness, adjust the deflection yoke, focusing device or centering magnet to eliminate them. Tilting the focusing device sometimes aids in beam centering. *The ion-trap magnet should never be used to center the raster or eliminate corner shadow if, in so doing, the screen brightness is reduced.*

With the magnet at its optimum position, make it tight. If the magnet is coded with a dot or arrow, the coding should be toward the picture-tube face. Should a magnetic shunt be clipped on the magnet, do not disturb it.

Some manufacturers consider the ion-trap adjustment of such importance that they coat the edge of the accelerating anode opening with a luminescent material. This gives a warning fluorescent glow, usually blue or green, when the electron beam is off center. The ion-trap magnet should be set for minimum glow in the neck of this type tube.

Keep in mind that the ion-trap adjustment and the focusing and center-

HEATH company

A SUBSIDIARY OF DAYSTROM, INC.

BENTON HARBOR 20,
MICHIGAN

NEW Heathkit 5" PUSH-PULL OSCILLOSCOPE KIT FOR COLOR TV

BRAND NEW DESIGN: The new Heathkit Model O-10 Oscilloscope would be something special at any price, but is almost unbelievable at \$69.50. Completely re-designed scope has broadband amplifiers for color TV work and offers brilliant overall performance. Vertical frequency response within 5 db from 5 cps to 5 mc. Even more astounding, the response is down less than 1½ db at 3.58 mc. the color TV sync burst frequency. It is essential that scopes for color work have these broadband characteristics.

PRINTED CIRCUITS: Two printed circuit boards used in this fine instrument to insure stable, consistent performance. Problems solved by pre-engineering of boards, and their use guarantees completed unit that will have same characteristics as lab development model. Printed circuits simplify construction and save labor.

NEW SWEEP CIRCUIT: Sweep circuit operates with exceptionally good linearity from 20 cps to over 500,000 cps. 5 times the usual range for scopes in this price range. An entirely new circuit introduced for the first time in any Heathkit.

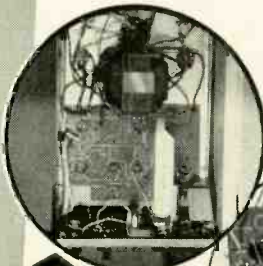

Clean, open, under chassis construction and wiring. Possible only through use of pre-cabled wiring harness, and simplified printed circuit boards.

Simplified, standardized construction technique of vertical and horizontal amplifier construction made possible through the use of a single printed circuit board.

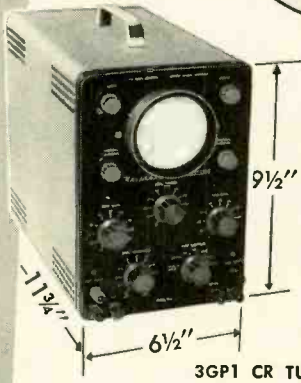
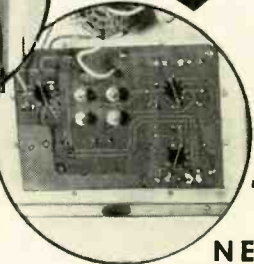

3GP1 CR TUBE

New compact utility Scope—light weight—portable for service work.

Deflection plate terminals—ideal for ham transmitter modulation monitoring.

EXCEPTIONAL VALUE: The brand new Model OL-1 Utility Oscilloscope is designed especially for portable applications so that outside servicemen or persons performing field tests can have the advantages of a scope available. Then too, it is ideal for home workshop, the ham-shack, or as an "extra" scope for the service shop. It is compact, light in weight, and surprisingly versatile in operation. An outstanding instrument for the price.

Front panel controls are "bench-tested" for ease of operation and convenience. Printed circuit board used for constant circuit performance. Assembly time cut in half!

SPECIFICATIONS: Vertical amplifiers feature frequency response within 1 db from 10 cps to 100 kc, and within 5 db from 5 cps to 500 kc. Vertical sensitivity .2 volts per inch at 1 kc, with input impedance of 12 mmfd shunting 10 megohms.

Horizontal response within 1 db from 10 cps to 200 kc, and within 5 db from 5 cps to 500 kc. Hor. sensitivity .25 volts per inch at 1 kc, input impedance of 15 mmfd shunting 10 megohms. Sweep generator covers 10 cps to 100,000 cps with stable positive lock-in circuit. Cathode follower input in both vert. and hor. amplifiers; push-pull vertical and horizontal deflection amplifiers; 3" CRT; electronic positioning controls for wide range of vertical and horizontal spot deflection; provision for internal and external sync; 60 cycle line sweep. New modern color styling and unusual performance make this instrument an outstanding value.

First color television service Oscilloscope with necessary high sensitivity and full 5 megacycle bandwidth.

New printed circuit construction. All components mounted on high insulation in unit resulting in uniformly low circuit capacities.

New type wide frequency range Heath sweep generator, 10 cycles to 500,000.



New 5UP1 CR tube

New cabinet styling and color harmony—charcoal gray panel with high readability white lettering.

New electronic positioning controls for instantaneous, definite positioning without bounce or overshoot.

MODEL O-10

\$69.50

Shpg. Wt. 27 lbs.

FEATURES: Other outstanding characteristics of this professional oscilloscope are: Built-in 1V peak-to-peak reference for calibration of plastic CRT face-plate; 5" 5UP1 CRT; push-pull hor. and vert. deflection amplifiers; hor. trace width expandable to 3 times diameter of CR tube to allow inspection of any small portion of the signal; deflection sensitivity, .025 volts per inch; wiring harness pre-formed and cabled to save construction time and insure professional appearance and operation. Incorporates efficient retrace blanking. Frequency compensated step attenuator at the vertical input. Entire tube face useable. No foldover on vertical over-load. Performance obtainable only in much more expensive laboratory models.

Uses 5UP1, 6AB4, 6BO7, 12BH7, 6CB6, 12AT7, 2-12AU7, 6X4, 1V2, and 6C4. Quality components used throughout so that outstanding performance characteristics may be maintained for years to come. Plastic molded condensers are used in all coupling and by-pass applications. The "new-look" in Heathkit styling produces professional appearance in keeping with the professional performance of this instrument.

NEW Heathkit 3" PRINTED CIRCUIT

OSCILLOSCOPE KIT

MODEL OL-1

\$29.50 Shpg. Wt. 15 lbs.

New easy-to-build printed circuit board with high insulation factor.

New Heathkit instrument styling—charcoal gray panel with high readability white lettering.

New Heath twin triode sweep generator 15-100,000 cycle sweep.

NEW Heathkit 5" PRINTED CIRCUIT

OSCILLOSCOPE KIT

MODEL OM-1

\$49.50 Shpg. Wt. 24 lbs.

VERSATILE INSTRUMENT: The new Model OM-1 general purpose Oscilloscope represents an outstanding dollar value in reliable test equipment. Full 5 inch CRT. Printed circuit boards for ease of assembly, constant circuit characteristics, and rugged component mounting. Includes all the design features necessary for servicemen, students, experimenters, radio amateurs, etc. Frequency response of amplifiers flat within 1 db from 10 cps to 100 kc, and down only 7 db from 10 cps to 500 kc. Sweep generator range from 20 cps to 100,000 cps. Also features new Heathkit color styling with charcoal gray panel and high definition white lettering for readability even under subdued lighting conditions.

DESIGN FEATURES: A full-size, versatile oscilloscope at a price you can afford. Other features are: adjustable spot shape control; RF connections to deflection plates; direct coupled centering controls; external and internal sweep and sync; 60 cycle line sync; built in 1 volt peak-to-peak panel terminal reference voltage; professional appearance of cabinet, panel, and knob styling.

5BP1 CR TUBE



HEATH company

A SUBSIDIARY OF DAYSTROM, INC.
BENTON HARBOR 20,
MICHIGAN

Heathkit MULTIMETER KIT

The new Heathkit Multimeter is a "must" to complete the instrument lineup of any well equipped service shop. Here is an instrument packed with every desirable service feature, many of which are not found in other Multimeters. All of the measurement ranges you need or want. High sensitivity 20,000 ohms per volt DC; 5,000 ohms per volt AC.

★ ADVANTAGES

Complete portability through freedom from AC line power operation—provides service ranges of direct current measurements from 150 microamps up to 15 amperes—can be safely operated in RF fields without impairing accuracy of measurement.

★ RANGES

Full scale AC and DC voltage ranges are 0-1.5, 5, 50, 150, 500, 1500 and 5,000 volts. Direct current ranges are 150 microamps, 15, 150 and 500 milliamperes and 15 amperes. Resistances are measured from .2 ohms to 20 megohms in 3 ranges and db range from -10 to +65 db.

★ CONSTRUCTION

The Heathkit MM-1 features a unique resistor ring switch mounting assembly procedure. With this method of assembly the precision resistors are wired to the rings and range switch before actual mounting of the switch to the instrument panel. This procedure affords the advantage of simpler construction yet complete accessibility of precision resistors in event replacement is ever required. Ohmmeter batteries were selected for convenience of replacement and only standard commercially available types are used. Batteries consist of 1 type C flashlight cell and 4 Penlite cells. All batteries and necessary test leads are furnished with the kit.

20,000 ohms per volt sensitivity DC; 5,000 ohms per volt AC.

Polarity reversal switch eliminates transferring of test leads.

All 1% precision multipliers—resistors—sensitive 50 microamp $\frac{1}{2}$ " Simpson meter.

Total of 35 meter ranges on two color scale.

New modern cabinet styling—Attractive appearance.



MODEL MM-1

\$29.50

Shpg. Wt. 6 lbs.

Heathkit HANDITESTER KIT



MODEL M-1

\$14.50

Shpg. Wt. 3 lbs.

The Heathkit Model M-1 Handitester readily fulfills major requirements for a compact, portable volt-ohm milliammeter. The small size of the smooth gleaming molded bakelite case permits the instrument to be tucked into your coat pocket, toolbox or glove compartment of your car. Always the "Handitester" for those simple repair jobs.

RANGES:

Despite its compact size, the Handitester is packed with every desirable feature required in an instrument of this type. AC or DC voltage ranges, full scale, 10, 30, 300, 1,000 and 5,000 volts. 2 convenient ohmmeter ranges 0-3,000 ohms and 0-300,000 ohms. 2 DC milliammeter ranges 0-100 milliamperes and 0-100 milliamperes.

CONSTRUCTION

The instrument uses a 400 microampere meter movement which is shunted with resistors to provide a uniform 1 milliamperes load in both AC and DC ranges. This design allows the use of but 1 set of 1% precision divider resistors on both AC and DC and provides a simplicity of switching. A small hearing aid type ohms adjust control provides the necessary zero adjust function on the ohmmeter range. The AC rectifier circuit uses a high quality Bradley rectifier and a dual half wave hookup. Necessary test leads and battery are included in the price of this popular kit.

Heathkit RESISTANCE SUBSTITUTION BOX KIT

MODEL RS-1

\$5.50



Shpg. Wt. 2 lbs.

36 standard RTMA 1 watt resistor values between 15 ohms and 10 megohms with an accuracy of 10% are at your fingertips in the Model RS-1 Resistance Substitution Box kit. This sturdy and attractive accessory will easily prove its worth many times over as a time saving device. Order several today.

Heathkit CONDENSER SUBSTITUTION BOX KIT

MODEL CS-1



\$5.50

Shpg. Wt. 2 lbs.

18 standard RTMA values are available from .0001 mfd to .22 mfd. An 18 position switch set in the panel of an attractive bakelite case allows quick changes without touching the test leads. Invest a few minutes of your time now and save hours of work later on.

HEATH company

A SUBSIDIARY OF DAYSTROM, INC.

BENTON HARBOR 20,
MICHIGAN

TELEVISION

ing controls are usually interdependent. Any adjustment of one will usually necessitate an adjustment of the others. However, make the final adjustment that of the ion-trap magnet, and do it carefully—picture tubes are expensive.

Defective crystal

The picture became very faint in an RCA model 17T150. The raster was bright, and what could be seen of the picture was clear. After checking the video amplifier I discovered the video detector crystal, marked CR101, was defective. I replaced it with a 1N64 which I have used in similar circuits. The picture returned with normal brightness but seemed to lack detail. There even seemed to be slight smearing.

I have replaced all tubes in the video amplifier and have aligned — to the best of my ability — the i.f. amplifier. Other components checked in the video amplifier match with my schematic. I would appreciate any suggestions you may have.—H. M., Groton, Conn.

RCA uses various types and makes of crystals for CR101, the most common being the 1N60, 1N64 and CK706. Their characteristics vary slightly and the crystals are often not directly interchangeable. On the production line RCA compensates for these variations by changing the value of the resistor across the primary of the fifth i.f. transformer which is normally 10,000 ohms. By varying this resistance from 5,600 to 10,000 ohms a value that gives optimum video response will be reached. In many cases the most practical approach is to replace the fifth i.f. video transformer containing the diode, shunt resistor and other video detector components. This assures a good match. If the smear cannot be eliminated, check the value of the load resistor in the plate circuit of the video amplifier.

Oscillation in output stage

I have a very peculiar condition in a G-E model 12K1. When the set is turned on, it operates perfectly until I change channels. At this time horizontal sync is lost and I cannot obtain stable sync despite turning the horizontal hold on the front panel and in the rear through their full range. However, when the set is turned off for a few minutes and then turned on, it will play perfectly again until I change channels. I have changed every tube in the horizontal sweep circuit without success. I don't see why a change in signal should affect a circuit that is supposed to operate continuously.—A. H., Fort Wayne, Ind.

The symptoms you describe could very well be caused by a defect in the horizontal a.f.c. circuit. However, this effect is fairly common in receivers using a horizontal output circuit where a voltage is fed back to the grid of the horizontal output tube from the secondary of the flyback transformer.

NEW *Heathkit* VACUUM TUBE VOLTMETER KIT PRINTED CIRCUIT DESIGN

Another outstanding example of continuing Heath Company pioneering and leadership in the kit instrument field. A new **printed circuit** VTVM. New peak-to-peak circuit—new styling and new panel design. A prewired, prefabricated printed circuit board eliminates chassis wiring, cuts assembly time in half, assures duplication of Engineering pilot model specifications, and virtually eliminates possibility of construction error.

CIRCUIT:

A 6AL5 tube operated as a full wave AC input rectifier permits seven peak-to-peak voltage ranges with upper limits of 4000 volts P—P. Just the ticket for you TV servicemen. Voltage divider in the 6AL5 input circuit limits applied AC input to a safe level. This circuitry and the isolation of the meter in the cathode of the 12AU7 bridge circuit affords a high degree of protection to the sensitive 200 microampere meter.

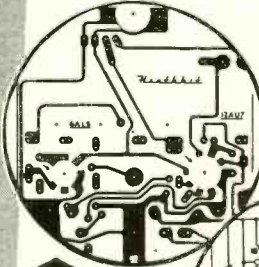

The first kit instrument to offer a labor-saving, error-free printed circuit board. Your instrument an exact wiring replica of Engineering development model.

Full wave rectifier in AC input circuit. Read peak-to-peak and RMS volts with upper limit of 4000 P—P and 1500 volts RMS. Voltage divider input circuit.

RANGES:

Seven voltage ranges. 1.5, 5, 15, 50, 150, 500 and 1,500 volts DC and AC RMS. Peak-to-peak ranges 4, 14, 40, 140, 400, 1400, 4000. Ohmmeter ranges X1, X10, X100, X1000, X10K, X100K, X1 meg. Additional features are a db scale, a center scale zero position, and a polarity reversal switch.

IMPORTANT FEATURES:

High impedance 11 megohm input—transformer operated—1% precision resistors, 6AL5 and 12AU7 tube—selenium power rectifier—individual AC and DC calibrations—smoother improved zero adjust control action—new panel styling and color—new placement of pilot light—new positive contact battery mounting—new knobs—test leads included.

The new V-7 also sets the pace as a kit instrument style leader. Smart, good-looking charcoal gray panel and soft leather gray cabinet. High readability panel with sharply contrasting white calibrations. The pleasing, eye catching, modern styling is in harmonious balance with the outstanding circuit design improvements. Easily the best buy in kit instruments.

New charcoal gray baked enamel panel with high readability white lettering. New soft leather gray cabinet, subdued pilot light indicator.

New printed circuit board for faster, easier construction—exact duplication of Lab development model.



New easy-to-read open panel layout. Off-on switch out. Now incorporated in the selector switch.

MODEL V-7

\$24⁵⁰

Shpg. Wt. 7 lbs.

New peak-to-peak meter scale—new color harmony—new knobs.

Heathkit AC VACUUM TUBE VOLTMETER KIT

MODEL AV-2

\$29⁵⁰

Shpg. Wt.
5 lbs.

Extreme sensitivity has been emphasized in the design of the Heathkit AC VTVM. Ten full scale RMS ranges are .01, .03, .1, .3, 1, 3, 10, 30, 100, and 300 volts. Frequency response is substantially flat from 10 cycles per second to 50 KC with input impedance of 1 megohm at 1 KC. Will accurately measure as low as 1 millivolt at high impedance. Total db range is -52 db to +52 db. An excellent kit for measuring

the output of phono cartridges and the gain of amplifier stages. Use it also to check power supply ripple, as a sensitive null detector, and for compiling frequency response data. Features one knob operation, 200 microampere Simpson meter and precision resistors.

Heathkit AUDIO WATTMETER KIT

Read audio power output directly without using external load resistors with the new Heathkit Audio Wattmeter. Built-in non-inductive load resistors provide impedances of 4, 8, 16, and 600 ohms. Flat response from 10 CPS to 250 KC. Full scale power ranges are 0-5 MW, 0-50 MW, 0-500 MW, 0-5 W and 0-50 W. Model AW-1 will operate continuously at 25 watts and has a duty cycle of 3 minutes at 50 watts. Total db range in five positions is -50 db to +48 db, using the standard 1 milliwatt 600 ohms.

MODEL AW-1

\$29⁵⁰

Shpg. Wt. 6 lbs.



Heathkit 30,000 VOLTS DC PROBE KIT

Measure up to 30,000 volts DC with the Heathkit VTVM and the 336 high voltage Probe. Precision resistor provides multiplication factor of 100. Can be used with any 11 megohm input VTVM. Housed in a Polystyrene two color sleek plastic probe body for safety of operation.

No. 336

\$4⁵⁰

Shpg. Wt.
1 lb.



Heathkit PEAK-TO-PEAK PROBE KIT



No. 338-C

\$5⁵⁰

Shpg. Wt. 2 lbs.

Peak-to-peak values not exceeding 80 volts at a DC level of not more than 600 volts, can now be read directly by using 338-C Probe with previous model Heathkit VTVM's or any VTVM with 11 megohm input resistance. Probe construction features a modern printed circuit board for easy assembly. Frequency range 5 KC to 5 MC.

Heathkit RF PROBE KIT

The Heathkit RF Probe will permit the measurement of RF voltages up to 250 MC with an accuracy of ±10%. The limits are 30 volts AC and a DC level of 500 volts. Designed for any 11 megohm input VTVM. Modern styling, Polystyrene aluminum housing, Polystyrene insulation, and printed circuit board for easy assembly.



No. 309-C

\$3⁵⁰ Shpg. Wt.
1 lb.

HEATH company

A SUBSIDIARY OF DAYSTROM, INC.

BENTON HARBOR 20,
MICHIGAN

Heathkit 6-12 VOLT BATTERY ELIMINATOR KIT

Here is the new 12 volt Heathkit Battery Eliminator so necessary for modern up-to-date operation of your Service Shop. Furnishes either 6 or 12 volt output which can be selected at the flick of a panel switch. Use the BE-4 to service all of the new 12 volt car radios in addition to the conventional 6 volt models.

RANGES:

This new Battery Eliminator provides two continuously variable output voltage ranges. 0-6 volts D.C. at 10 amperes continuously or 15 amperes maximum intermittent and 0-12 volts D.C. at 5 amperes continuously or 7.5 amperes maximum intermittent. The output voltage is clean and well filtered, as the circuit uses two 10,000 mfd condensers.

The continuously variable voltage output feature is of definite aid in determining the starting point of vibrators, the voltage operating range of oscillator circuits, etc.

OTHER USES:

The controllable low voltage DC supply has many other applications besides primary use in car radio service work. Can be nicely used as a battery charger, or low voltage DC supply for electric trains. Has applications in high gain audio work requiring clean DC filament supply. Can be used for low power electro-plating or as a power supply for battery powered intercommunication systems.

Automatic overload relay—self resetting—fuse protected.

New 18 plate split tifer unit.



Continuously variable output voltage, either 6 or 12 volt operation.

Constant ammeter and voltmeter monitoring.

MODEL BE-4

\$31⁵⁰

Shpg. Wt. 17 lbs.

Heathkit VIBRATOR TESTER KIT

MODEL VT-1

\$14⁵⁰

Shpg. Wt. 6 lbs.



This time-saving device will quickly pay for itself in your auto radio service shop. 6 volt vibrators can be checked instantly on the Good—Bad type meter scale. Operation requires only a variable DC voltage from 4 to 6 volts at 4 amperes. Model BE-4 Battery Eliminator is recommended for this application.

Five test sockets provide for the testing of hundreds of interrupter and self-rectifier types. Proper starting voltage is determined easily and accurately. Over-all quality is then unmistakably indicated on the panel mounted meter.

Heathkit IMPEDANCE BRIDGE KIT

MODEL IB-2

\$59⁵⁰ Shpg. Wt. 12 lbs.



The new Heathkit Impedance Bridge features built-in adjustable phase shift oscillator and amplifier. This instrument actually represents four instruments in one compact unit. The Wheatstone bridge for resistance measurements, the Capacity Comparison bridge for capacity measurements, Maxwell bridge for low Q, and Hay bridge for high Q measurements.

DESIGN:

Panel provisions for external generator use. A new two section CRL dial, provides ten separate "units." Ten separate units switch settings and fractions of units are read on a continuously variable calibrated control. A special minimum capacity shielded and balanced impedance matching transformer between the generator and bridge circuit is automatically switched to provide correct load operation of the generator circuit. The instrument uses 1/2% precision resistors and condensers in all measurements circuits.

Heathkit VARIABLE VOLTAGE ISOLATION TRANSFORMER KIT

Variable output voltage between 90 and 130 volts AC. Rated at 100 volt—amperes continuously and 200 volt—amperes intermittently. The principle function of the Heathkit Isolation Transformer is to isolate the circuit being tested from line interference being caused by motors, appliances, etc. It works backward too by isolating such devices from the line. Many other uses, especially with AC—DC type circuits. Do not confuse the Heathkit Isolation Transformer with the hazardous auto transformer type line voltage boosters.



MODEL IT-1

\$16⁵⁰

Shpg. Wt. 10 lbs.

HEATH company

A SUBSIDIARY OF DAYSTROM, INC.

BENTON HARBOR 20,
MICHIGAN

TELEVISION

The trouble is probably oscillation in the output stage due to excessive feedback. You can check this by removing the horizontal oscillator tube once the trouble starts. If you continue to have sweep and high voltage, this unwanted oscillation is taking place. When the 6- μf feedback capacitor (C330 on G-E diagrams) breaks down, it changes in capacitance to as much as 300 μf . This gives sufficient feedback for oscillation. Thus when the control voltage from the a.f.c. circuit is altered during channel changes, self-oscillation takes over. Replace this unit with a 1,500-volt mica capacitor.

Picture and sound loss

I am servicing a Meck receiver which apparently has a bad tuner. I get no picture and no sound, but a raster is present. I would like some information on replacing the existing tuner with the new Standard cascode tuner. There is no model number on this receiver, but the circuit checks with the Meck model XQA. H. S., Cleveland, Ohio.

You mentioned that the tuner is bad, but did not explain how you arrived at this conclusion. If this receiver is similar to the XQA model, it is an intercarrier receiver and the sound take-off is at the video amplifier. In such an instance the lack of picture and sound (with a raster present) could be caused by a defective tube or circuit in the tuner, the video i.f. amplifiers, the video detector or the video amplifier. Thus, your idea of replacing the tuner to correct this trouble may not be the solution. If a defective tube or part exists in the video i.f. stages or the detector or video amplifier, the new tuner would be of no help.

The Standard cascode tuner is supplied with complete schematic and installation instructions. You can find additional information on cascode tuners in previous issues of RADIO-ELECTRONICS as follows: January, 1953, page 49; September, 1953, page 58; January, 1954, page 43.

Poor focus

I recently replaced a 19AP4A picture tube in a Sentinel model 425 receiver. This seriously disturbed the focusing, especially around the center of the picture. Adjusting the focus magnet was of some help, but still left the picture badly focused. What could have caused the trouble?—C. D., Scranton, Pa.

This very common trouble in the case of replaced 19AP4A metal tubes is caused by changes in electrical design of the tube. A remedy which in most instances is highly effective is to lower the d.c. plate voltage to the horizontal output tube. This can be done by inserting a 1,000-ohm, 5- to 10-watt resistor between the horizontal output transformer and the boost voltage source (linearity coil). Adjust the horizontal drive to -25 volts. If width is lacking, shunt a .05- μf capacitor across the width coil. END

NEW *Heathkit* TV ALIGNMENT GENERATOR KIT

Here is the most radically improved Sweep Generator in the history of the TV service industry. The basic design follows latest high frequency techniques which result in a combination of performance features not found in any other sweep generator.

SWEEP:

Sweep action is obtained electronically through the use of a newly developed controllable inductor, thereby eliminating all moving parts with their resultant hum, vibration, fatigue, etc. Frequency coverage entirely on fundamentals, is continuous from 4 MC to 220 MC at an output level well over a measurable .1 volt.

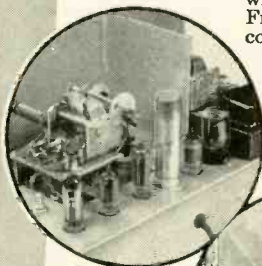

Triple marker system. 4.5 MC crystal controlled marker—continuously variable marker—provisions for external marker.

Automatic amplitude control circuit—constant output voltage regulated power supply.

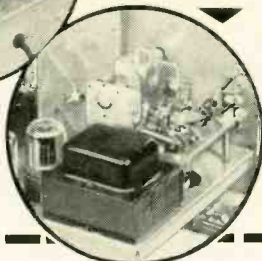

MARKER:

The same instrument incorporates a triple marker system with a crystal controlled reference. A variable marker provides accurate coverage from 19 to 60 MC on fundamentals, and 57 to 180 MC on calibrated harmonics. A separate fixed crystal controlled 4.5 MC marker can be used for checking IF, band-pass, calibration, reference, etc. Provisions are also made for external marker use. A 4.5 MC crystal is supplied with the kit.

POWER SUPPLY:

The transformer operated Power Supply features voltage regulation for stable oscillator operation. Three sets of shielded cables are furnished with the kit. Sweep range is completely and smoothly controllable from zero up to a maximum of 42 MC, depending upon base frequency.

Here is a TV Sweep Generator that truly no serviceman can afford to be without for rapid, accurate, TV alignment work.

Controllable inductor sweep oscillator with output entirely on fundamentals.

Triple marker system 4.5 MC crystal controlled—3 sets of cables included.

Electronically operated, smoothly continuously variable sweep circuit. No vibration, hum or noise.

Frequency coverage: 4 MC—220 MC continuous including FM spectrum. RF output well over .1 volt.



MODEL TS-4

\$49.50

SHPG. WT.
16 LBS.

NEW *Heathkit* SIGNAL GENERATOR KIT



MODEL SG-8

\$19.50 Shpg. Wt.
8 lbs.

The new Heathkit service type Signal Generator, Model SG-8 incorporates many design features not usually found in this instrument price range. Frequency coverage is from 160 KC to 110 MC in five ranges, all on fundamentals, with useful calibrated harmonics up to 220 MC. The RF output level is well in excess of 100,000 microvolts throughout the frequency range. The oscillator circuit consists of a twin triode tube, one-half used as a Colpitts oscillator, and the other half as a cathode follower output which acts as a buffer between the oscillator and external load, thereby eliminating oscillator frequency shift usually caused by external loading.

All coils are factory wound and adjusted, thereby completely eliminating the need for individual calibration and the use of additional calibrating equipment. The stable, low impedance output, features step and variable attenuation for complete control of RF level. A separate 6C4 triode acts as a 400 cycle sine wave oscillator, and a panel mounted switching system permits choice of either external or internal modulation.

The new Heathkit Laboratory type Signal Generator definitely establishes a new performance standard for a kit instrument. An outstanding feature involves the use of a panel mounted 200 microampere meter calibrated both in microvolts and percent modulation, thereby providing a definite reference level for using the Signal Generator in design work, gain measurements, selectivity, frequency response checks.

Heathkit LABORATORY GENERATOR KIT



MODEL LG-1

\$39.50

Shpg. Wt. 16 lbs.

DESIGN:

Additional design features are copper plated shield enclosure for oscillator and buffer stages resulting in effective double shielding. Fibre panel control shaft extensions in RF carrying circuits, thorough AC line filtering, careful shielding of the attenuator network, voltage regulated B plus supply, selenium rectifier, etc.

RANGES:

Frequency coverage from 150 KC to 30 MC all on fundamentals in five separate ranges. Output voltage .1 volt with provisions for metered external or internal modulation. Output impedance termination 50 ohms. Transformer operated power supply.

Investigate the many dollar stretching features offered by the LG-1 before investing in any generator for Laboratory or Service work.

NEW *Heathkit* BAR GENERATOR KIT



MODEL
BG-1

\$14.50 Shpg. Wt.
4 lbs.

The Heathkit BG-1 produces a series of horizontal or vertical bars on a TV screen. Since these bars are equally spaced, they will quickly indicate picture linearity of the receiver under test without waiting for transmitted test patterns. Panel switch provides "standby"—horizontal and vertical position. The oscillator unit uses a 12AT7 twin triode for the RF oscillator and video carrier frequencies. A neon relaxation oscillator provides low frequency for vertical linearity tests. The instrument will also provide an indication of horizontal and vertical sync circuit stability as well as overall picture size. Operation is simple and merely requires connection to the TV receiver antenna terminal. Transformer operated for safety.

HEATH company

A SUBSIDIARY OF DAYSTROM, INC.
BENTON HARBOR 20,
MICHIGAN



Heathkit VISUAL-AURAL SIGNAL-TRACER KIT

The new Heathkit Visual-Aural Signal Tracer features a special high gain RF input channel used in conjunction with a newly designed wide frequency range demodulator probe. High RF sensitivity permits signal tracing from the receiver antenna input. Separate low gain channel and probe available for audio circuit exploration. Both input channels are constantly monitored by an electron ray beam indicator so that visual as well as aural indications may be obtained.

NOISE LOCATOR:

A decidedly unusual feature is a noise locator circuit used in conjunction with the audio probe. With this system, a DC potential is applied to a suspected circuit component and the action of the voltage in the component can be seen as well as heard. Invaluable for ferreting out noisy or intermittent condensers, noisy resistors, controls, IF and power transformers, etc.

WATTMETER:

Built-in calibrated wattmeter circuit will prove useful for quick preliminary check of total wattage consumption of equipment under test. Separate panel terminals provide external use of the speaker or output transformer for substitution purposes. Saves valuable service time by eliminating the necessity for speaker removal on every service job. The same panel terminals also provide easy access to a well filtered B plus supply for external use. Don't overlook the many interesting service possibilities provided through the use of this instrument, and let the Signal Tracer work for you by saving time and money.



Substitution test speaker—utility amplifier.

Noise locator circuit—calibrated wattmeter.

RF and audio probes supplied along with necessary test leads.

Visual and aural signal tracing.

MODEL T-3
\$23⁵⁰

Shpg. Wt. 9 lbs.

Heathkit CONDENSER CHECKER KIT



MODEL C-3

\$19⁵⁰ Shpg. Wt. 7 lbs.

Here is a handy test instrument for any Service Shop. Unknown values of capacity and resistance are quickly determined on the direct reading condenser checker dial. Capacity is measured in four ranges from .001 mfd to 1000 mfd. Resistance in the range from 100 ohms to 5 megohms.

DC polarizing voltages of 25, 150, 250, 350, and 450 volts are available for leakage tests on all types of condensers. For electrolytics, a power factor control is provided to balance out inherent leakage and to indicate directly the power factor of a condenser under test. Proper balancing of the AC bridge is reflected in the degree of closure of an electron beam indicator tube.

Model C-3 uses a transformer operated power supply, spring return leakage test switch, and a convenient combination of panel scales for all readings. Test leads are furnished in addition to precision components for calibrating purposes. Quick and easy to operate, the Heathkit Condenser Checker will save valuable time and increase your Shop efficiency.

Heathkit "Q" METER KIT



MODEL QM-1

\$44⁵⁰

Shpg. Wt. 14 lbs.

The Heathkit QM-1 represents the first practical popular priced Q meter available within the price range of schools, laboratories, TV service men, and experimenters. This instrument will enable the operator to simulate conditions encountered in practical circuits and to measure the performance of coils or condensers at the operating frequencies actually encountered. All indications of value are read directly on the $4\frac{1}{2}$ " 50 microampere Simpson calibrated meter scale. Measures Q of condensers, RF resistance, and the distributed capacity of coils. Oscillator section supplies RF frequencies 150 KC to 18 MC in four ranges. Calibrate capacity with range of 40 MMF to 450 MMF with vernier of ± 3 MMF. Investigate the many services this instrument can perform for you.

Heathkit AUDIO OSCILLATOR KIT



MODEL AO-1

\$24⁵⁰

Shpg. Wt. 10 lbs.

The Heathkit Audio Oscillator will produce both sine and square waves within the frequency range from 20 CPS to 20 KC in three ranges. Thermistor controlled linearity results in a variation of no more than ± 1 db in a 10 volt (no load) variable output level. There will be less than .5% distortion from 100 CPS throughout the audible range. Low impedance 600 ohm output. Precision 1% resistors, used in the range multiplier circuits to provide accurate calibration.

HEATH company

A SUBSIDIARY OF DAYSTROM, INC.

BENTON HARBOR 20,
MICHIGAN

ARISING sunspot curve, the first January aurora of major proportions in several years, the most active winter skip season in the history of TV dx—these are the signs that make for optimism among the TV dx enthusiasts. The next three months, April through June, will tell the story, for in this period comes the rush of sporadic-E dx that everyone waits for through the early spring.

Dx-ers in the Gulf States may get their first licks in sometime in the latter part of March or early April. More northerly observers will more than likely have to wait until May before catching many good ones, if 1955 follows previous years. Indications are, however, that this spring's activity will get under way earlier than any since chasing TV dx became a major hobby.

Observer Bedford Brown, Jr., Hot Springs, Ark., logged 37 stations during January, 23 of them sporadic-E dx. Mexico and Texas stations were logged between 11:20 am and 8:05 pm, Jan. 1, channels 2, 4 and 5. Jan. 3, 4:30 to 6:10 pm, Bedford caught WCBS, N. Y.; XEW, Mexico City, and CBFT, Montreal, all channel 2. Jan. 4, 4:30 to 9:00 pm: WUSN-2, Charleston, S. C.; WSB-2, Atlanta, Ga. (523 miles, short skip for winter); WFMY-2, Greensboro, N. C.; WBTV-3, Charlotte, N. C.; WMBR-4, Jacksonville, Fla.; WCSC-5, Charleston, S. C., and WMFD-6, Wilmington, N. C. Jan. 5: several unidentified, northeast. Jan. 18, 7 am: WMBR. Jan. 25, 9-9:30 pm; CMQ-TV, Havana, Cuba. Jan. 28: unidentified, northeast. Jan. 31, 4:30 to 7 pm: XEW-2, XHTV-4 and XHGG-5, all Mexico City; KRGV-5, Weslaco, and KGBT, Harlingen, Tex.; KUTV-2, Salt Lake City, Utah; KFEL-2 and KOA-4, Denver, Colo.; KTVT-4 and KSL-5, Salt Lake City. Quite a list, for January!

Brown also reports burst reception almost every day, though he has identified only five stations in 3½ years by this medium—presumably reflections from meteor trails. His catches via bursts include WBEN-4, Buffalo, N. Y.; WBZ-4, Boston, Mass.; WRGB-4 (now 6), Schenectady, N. Y.; WEWS-5, Cleveland, Ohio, and WSPD-13, Toledo, Ohio.

Tommy Blalock, Tallahassee, Fla., reports that his January skip reception was in longer, with steadier signals, than he has ever experienced before in the winter months. His best days were Jan. 23, 27, 28 and 31, with reception from Denver, Mexico City, Midland and El Paso, Tex., channels 2-5.

(Continued on page 77)

Heathkit TUBE CHECKER KIT

The Heathkit TC-2 Tube Checker was primarily designed for the convenience of radio and TV servicemen and will check the operating quality of tubes commonly encountered in this type of work. Test set-up procedure is simplified, rapid, and flexible. Panel sockets accommodate 4, 5, 6, and 7 pin tubes, octal and loctal, 7 and 9 pin miniatures, 5 pin Hytron, and a blank socket for new tubes. Built-in neon short indicator, individual 3-position lever switch for each tube element, spring return test switch, 14 filament voltage ranges, and line-set control to compensate for supply voltage variations, all represent features of the TC-2.

Illuminated for easy reading and quick identification of chart

Simplified construction—new harness type wiring—closer tolerance resistors.

Smart, professional appearance—available in counter or portable models.

Improved smooth running roll chart mechanical action.

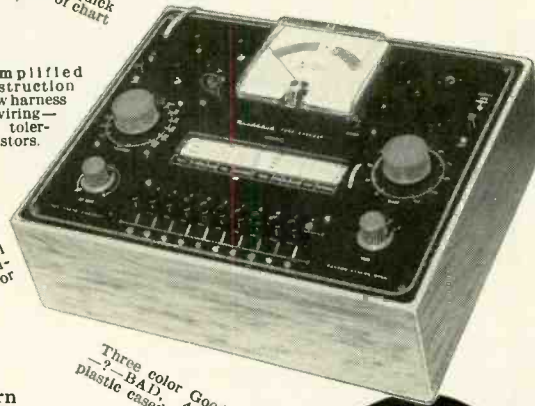

Three color Good—9-BAL, 4 1/2" plastic cased meter.

MODEL TC-2

\$29.50

Shpg. Wt. 12 lbs.

Heathkit PORTABLE

TUBE CHECKER KIT

The portable model is supplied with a strikingly attractive two-tone cabinet finished in rich maroon proxilin impregnated fabric covering with a contrasting gray on the inside of the detachable cover.

MODEL TC-2P

\$34.50

Shpg. Wt. 15 lbs.



Results of tube tests are read directly from the large 4 1/2" Simpson 3-color meter. Checks emission, shorted elements, open elements, and continuity. Wiring procedure has been simplified through the use of multi-wired color coded cable providing a harness type installation between tube sockets and lever switches. This procedure insures standard assembly and imparts a "factory built" appearance to the instrument. New Construction Manual furnishes detailed information regarding tube set-up procedure for testing of new or unlisted tube types. No delay necessary for release of factory data.

Heathkit

REGULATED POWER SUPPLY KIT



MODEL PS-2

\$33.50

Shpg. Wt. 15 lbs.

Here is a source of regulated D.C. voltage for circuit development work. Power supply voltage and current drain to the circuit under test are constantly monitored by the 4 1/2" panel mounted meter. Separate 6.3 volt at 4 ampere A.C. filament source available. The regulated and variable output voltage will be constant over wide load variations, and hum ripple will not exceed .012% at 250 volts under a 50 MA load. Completely isolated circuit, standby switch, and other desirable features, make the Model PS-2 extremely useful in a wide variety of applications.

Heathkit TV PICTURE TUBE TEST ADAPTER

The Heathkit TV Picture Tube Test Adapter used with the Heathkit Tube Checker Kit, will quickly check picture tubes for emission, shorts, etc. and determine tube quality. Consists of standard 12-pin TV tube socket, four feet of cable, octal socket connector, and data sheet.



No. 355

\$4.50 Shpg. Wt. 1 lb.

Heathkit

DECADE RESISTANCE KIT



MODEL DR-1

\$19.50

Shpg. Wt. 4 lbs.

Twenty 1% resistors are decade in 1 ohm steps to provide any value between 1 ohm and 99,999 ohms. Sturdy ceramic switches with silver plated contacts insure reliable service. Use the Decade Resistance in bridge circuits, meter multipliers, calibrations, or any application requiring a wide range of precision resistance values.

Heathkit AUDIO GENERATOR KIT

Here is an Audio Generator with features generally found only in the most expensive instruments. Sine wave coverage from 20 cycles to 1 Megacycle—response flat ± 1 db from 20 cycles to 400 Kc—continuously variable and step attenuated output. Because the output voltage is relatively constant over wide frequency ranges, the AG-3 is ideal for running frequency response curves in audio circuits. Once set by means of the attenuator, this voltage may be relied upon for accuracy within ± 1 db. Instrument features low impedance 600 ohm output circuit and distortion less than .4 of 1% from 100 CPS through audible range.



MODEL AG-8

\$29.50

Shpg. Wt. 11 lbs.

Heathkit DECADE CONDENSER KIT

The Heathkit Decade Condenser provides a ready source of capacity values from 100 mmf to .111 mfd inclusive in capacity steps of 100 mmf. Silver plated contacts on husky ceramic switches, assure positive contact for each switch position. Precision silver mica condensers $\pm 1\%$ accuracy for close tolerance accurate work.

MODEL DC-1

\$16.50

Shpg. Wt. 3 lbs.



HEATH company

A SUBSIDIARY OF DAYSTROM, INC.
BENTON HARBOR 20,
MICHIGAN

NEW *Heathkit* HIGH FIDELITY PREAMPLIFIER KIT

Here is the exciting new Heathkit Preamplifier with all of the features you Audiophiles have asked for and at a down-to-earth price level. Beautiful satin gold baked enamel finish, striking control knobs and arrangement, attractive custom appearance and entirely functional design.

DESIGN:

Uses three twin triode tubes in a shock mounted chassis, 2-12AX7 and 1-12AU7. Features tube shielding, plastic sealed color coded capacitors, smooth acting controls, good filtering, excellent decoupling, low hum and noise level, and all aluminum cabinet. Special balancing control for absolute minimum hum level. Cathode follower, low impedance output circuit for complete installation flexibility.

SPECIFICATIONS:

Provides five switch selected inputs, 3 high level, and two low level, each with individual level controls—4 position LP, RIAA, AES, and early 78 equalization switch—4 position roll-off switch, 8, 12, 16 with one flat position. Separate tone controls, bass 18 db boost and 12 db cut at 50 CPS, treble 15 db boost, and 20 db cut at 15,000 CPS. Power re-

Equalization for LP, RIAA, AES, and early 78.

Separate bass and treble tone controls—special hum control.



Cathode follower low impedance output circuit.

Beautiful, modern appearance, blends with any interior or color scheme.

Five switch selected inputs with individual level controls.

requirements from Heathkit Williamson Type Amplifier power supply 6.3 volts AC at 1 ampere, and 300 volts DC at 10 MA. Over-all dimensions 12 3/4" wide x 5 1/4" deep x 3 3/4" high.

APPLICATION:

The new Heathkit WA-P2 Preamplifier has been designed to operate with any of the Heathkit Williamson Type Amplifiers and is directly interchangeable with the previous Model WA-P1 Preamplifier unit. Order your kit today and enjoy completely smooth control over the operation of your Hi-Fi system. Obtain the exact tonal balance of bass and treble with the precise degree of equalization you want. Note that the design of the WA-P2 accommodates the newly established RIAA curve.

MODEL WA-P2

\$19.75

Shpg. Wt. 7 lbs.

HAM EQUIPMENT

Single knob band switching—prewound coils.

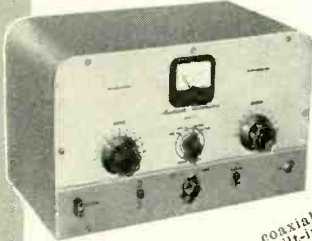

Crystal or VFO excitation—metered operation. 52 Ohm coaxial output—built-in power supply.

MODEL AT-1

\$29.50

Shpg. Wt. 16 lbs.

filter, good shielding and a 52 ohm coaxial output. The 425 volt, 100 milliampere power supply and 5U4 rectifier are more than adequate for the 6AG7 oscillator multiplier and 6L6 amplifier doubler.

Heathkit

AMATEUR

TRANSMITTER KIT

The Heathkit AT-1 Transmitter has established a high reputation and has been enthusiastically accepted by hundreds of experienced operators as well as beginners. Power input up to 35 watts for the novice and suitable as a standby exciter for your higher powered rig later on.

Model AT-1 can be crystal or VFO excited and operates on 80, 40, 20, 15, 11 and 10 meters. The prewound coils with the oscillator and amplifier are switched simultaneously

by the rugged band switch. Meter switch allows a reading of the final grid and plate current on the panel mounted meter. Modulator input and VFO power sockets are provided as well as a key jack for CW operation. Other features include a crystal socket, standby switch, key click filter, AC line filter, good shielding and a 52 ohm coaxial output. The 425 volt, 100 milliampere power supply and 5U4 rectifier are more than adequate for the 6AG7 oscillator multiplier and 6L6 amplifier doubler.

Brand NEW

Smooth acting illuminated and precalibrated dial.

HEATHKIT VFO KIT

The new Heathkit VFO is the perfect companion to the Heathkit Model AT-1 Transmitter and it has sufficient output to drive any multi-stage transmitter of modern design. Good mechanical and electrical design insures operating stability. Coils are wound on stable, heavy duty, ceramic forms using Litz or double cellulose wire coated with Polystyrene cement and baked for humidity protection. Variable capacitor of differential type construction, especially designed for maximum bandwidth. Kit is furnished with a carefully precalibrated scale which provides well over two feet of scale length. Smooth acting vernier reduction drive and illuminated dial provides easy tuning and zero beating.

Power requirements 6.3 volts AC at .45 amperes, and 250 volts DC at 15 mls. Just plug it into the power receptacle provided on the rear of the AT-1 Transmitter. Seven band coverage 160 through 10 meters with 10 volt average RF output. Uses 6AU6 electron coupled Clapp oscillator and OA2 voltage regulator.

Copper plated chassis—aluminum cabinet—easy to build.



Seven band coverage 160 through 10 meters at 10 volt RF output.

6AU6 electron coupled Clapp oscillator and OA2 voltage regulator.

MODEL VF-1

\$19.50

Shpg. Wt. 7 lbs.

Heathkit

GRID DIP METER KIT

The invaluable instrument for Hams, servicemen and experimenters. Useful in TV service work, for alignment of traps, filters, IF stages, peaking compensation networks, etc. Locates spurious oscillation, provides a relative indication of power in transmitter stages. Use it for neutralization, locating parasites, correcting TVI, measuring CL and Q of components, and determining RF circuit resonant frequencies. The variable meter sensitivity control, headphone jack, 500 microampere Simpson meter, continuous frequency coverage from 2 MC to 250 MC. Prewound coil kit and rack included.

LOW FREQUENCY COILS:

Low frequency range extended to 355 KC by the use of two additional coils. Complete with dial correlation curves. Set 341-A for GD-1B and set 341 for GD-1A. Shpg. wt. 1 lb. Price \$3.00



MODEL GD-1B

\$19.50

Shpg. Wt. 4 lbs.

Heathkit ANTENNA

IMPEDANCE METER KIT

MODEL AM-1

\$14.50

Shpg. Wt. 2 lbs.

Determine antenna resonance and resistance, transmission line surge impedance, and receiver input impedance. Works with one-half and one-quarter wave lines, half wave and folded dipoles, harmonic mobile and beam antennas. Resistance type SWR bridge—100 microampere meter—frequency range 0-150 MC—impedance range 0-600 ohms.



MODEL AC-1

\$14.50

Shpg. Wt. 4 lbs.

Heathkit

ANTENNA COUPLER KIT

For the Heathkit AT-1 Transmitter or any comparable Amateur Transmitter. Will handle power up to 75 watts at its 52 ohm coaxial input. Matches a wide range of antenna impedances with its L type tuning network and neon indicator. A tapped inductance provides coarse adjustment and a transmitting type variable condenser sets it "right on the nose." Will operate on the 10 through 80 meter bands.

HEATH company

A SUBSIDIARY OF DAYSTROM, INC.

BENTON HARBOR 20,
MICHIGAN

New LOW PRICED HEATHKIT SINGLE UNIT Williamson Type High Fidelity AMPLIFIER KIT

Here is the newest Heathkit Hi-Fi Amplifier at the lowest price ever quoted for a complete Williamson Type Amplifier circuit. The W-4 Model has been designed for single chassis construction, and only for the new Chicago Transformer Company Model BO-13 "super range" high fidelity output transformer. This transformer, a new development in the Hi-Fi field, is being offered at substantial saving over transformers of comparable quality. It is outstanding in performance and on the basis of our tests, we find it equal in every respect to transformers used in the W-2 and W-3 Heathkit series.

LOW PRICES:

Through utilization of a single chassis with resultant economy obtained through elimination of duplicate sheet metal fabrication, connecting cables, plugs, sockets, and a new Chicago "super range" output transformer, a 20% price reduction has been made possible without sacrificing kit quality.

COMPONENTS:

The new Heathkit W-4 uses the same heavy duty power transformer and choke. It has all of the features of previous models including individual jacks and a wire wound control to balance the output tubes—plastic high quality capacitors and the exact circuitry previously utilized in Williamson Type Amplifiers. Intermodulation distortion and harmonic distortion are both at the same low level as in the W-2 and W-3 models.

CONSTRUCTION:

Here is the opportunity for even the economy minded Hi-Fi enthusiast to enjoy all of the advantages offered through Hi-Fi reproduction of fine recorded music. Simplified step-by-step Construction Manual completely eliminates necessity of electronic knowledge or special equipment. Assemble this Amplifier in a few pleasant hours.

Rugged, heavy duty,
single chassis
construction.

Output Impedances
4, 8, and 16 ohms.



Standard
brand com-
ponents used,
no sacrifice of
quality.

Lowest price high quality
Williamson Type Ampli-
fier ever offered.

Send for
free booklet
"High
Fidelity
Especially
For You."

COMBINATIONS AVAILABLE

W-4M with Chicago "super-range" trans-
former only. Single chassis main amplifier
and power supply. Shipping weight 28 lbs. Express only **\$39.75**

COMBINATION W-4 with Chicago
"super-range" transformer only includes
single chassis main amplifier and power sup-
ply with WA-P2 preamplifier kit. Shpg. wt. 35 lbs. Express only **\$59.50**

NEW Heathkit 20 WATT High Fidelity AMPLIFIER KIT

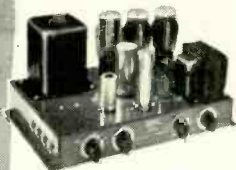

MODEL A-9B

\$35⁵⁰

Shpg. Wt. 24 lbs.

In keeping with the progressive policy of the Heath Company, further improvement has been made in the already famous Heathkit High Fidelity 20 Watt Amplifier. Additional reserve power has been obtained by using a heavier power transformer. A new output transformer designed and manufactured especially for the Heath Company, now provides output impedances of 4, 8, 16 and 500 ohms. The harmonic distortion level will not exceed 1% at the rated output.

FEATURES:

Outstanding features of the Heathkit 20 watt Amplifier include frequency response of ± 1 db from 20 CPS to 20 KC. Separate (boost and cut) bass and treble tone controls. Four switch selected input jacks and a special hum balancing control. Flexibility is emphasized in the in-

put circuits and proper equalization for all input devices is incorporated.

TUBE LINEUP:

12AX7 magnetic preamplifier and first audio amplifier. 12AU7 two stage amplifier with tone controls. 12AU7 voltage amplifier and phase splitter. Two 6L6 push-pull beam power output and 5U4G rectifier.

The Heathkit Model A-9B is excellent for custom installation and is designed for outstanding service at a very reasonable cost.

Heathkit SIX WATT AMPLIFIER KIT



MODEL A-7B

\$15⁵⁰

Shpg. Wt. 10 lbs.

An outstanding value, this econom-
ically priced 5 watt Amplifier is
capable of performance expected
only in much more expensive units.
Only 2 or 3 watts output will ever
be used in normal home applications
and Model A-7B will be more than
adequate for this purpose.

SPECIFICATIONS:

Two switch selected inputs are avail-
able for crystal and ceramic phono
pickups, tuner, TV audio, tape re-
corder, and carbon type microphone.
Model A-7B features separate bass
and treble tone controls, push-pull
balanced output stages, output im-
pedances of 4, 8, and 15 ohms, and extremely wide frequency
range $\pm 1\frac{1}{2}$ db from 20 CPS to 20 KC. Not just a souped up AC-
DC job. Full wave rectification, transformer operated power
supply and good filtering, result in exceptionally low hum level.

MODEL A-7C

Provides a preamplifier stage and proper compensation for the
variable reluctance cartridge and low level microphone. \$17.50

Heathkit WILLIAMSON TYPE AMPLIFIER KIT

Here is the famous kit form Williamson Type high fidelity Amplifier that has de-
servedly earned highest praise from every strata of Hi-Fi music lovers. Virtually
distortionless, clean musical reproduction, full range frequency response, and more
than adequate power reserve.

OUTPUT TRANSFORMERS:

This outstanding Williamson Type Hi-Fidelity Amplifier is supplied with the famous
Acrosound TO-300 output transformer. This quality transformer features the pop-
ular "ultra-linear" output circuit for clean maximum power level. Separate chassis for amplifier
and power supply.

SPECIFICATIONS:

Frequency response within 1 db from 10 cycles to 100,000 cycles. Harmonic distortion at 5 watt
output less than .5% between 20 cycles and 20,000 cycles. IM distortion at 5 watts equivalent
output .5% using 60 and 3,000 cycles. Output impedances of 4, 8, or 16 ohms. Overall dimensions
for each unit 7" high x 5 $\frac{1}{2}$ " wide x 11 $\frac{1}{2}$ " long.

CONSTRUCTION MANUAL:

This fine kit is supplied with a completely detailed step-by-step Construction Manual and the
only effort required is the assembly and wiring of the pre-engineered kit. Even the complete
novice can successfully construct this Amplifier and have fun building it.

COMBINATIONS AVAILABLE:

W-3 Amplifier Kit (Includes Main Ampli-
fier with Acrosound Output Transformer,
Power Supply and WA-P2 Preamplifier.)
Shipping weight 37 lbs. **\$69.50**
Shipped express only.

W-3M Amplifier Kit (Includes Main Am-
plifier with Acrosound Output Transformer
and Power Supply.) Shipping weight 29 lbs. Express only **\$49.75**



HEATH company

A SUBSIDIARY OF DAYSTROM, INC.

BENTON HARBOR 20,
MICHIGAN

Separate BFO oscillator tube and circuit.

Continuous coverage 550 KC-35 MC on 4 Bands.

Heathkit COMMUNICATIONS RECEIVER KIT



MODEL AR-2

\$25⁵⁰

(Less Cabinet)
Shpg. Wt. 12 lbs.

An excellent example of typical Heath Company ability to produce top quality kit merchandise at ridiculously low prices, is the AR-2 Communications Receiver. Here is a transformer operated all-wave receiver with all of the desired features and none of the disadvantages commonly encountered in so-called "economy sets."

Receiver employs high gain miniature tubes and IF transformers, chassis mounted 5½" PM speaker, headphone jack, slide rule dial with Ham Bands plainly identified, and easy tuning with direct planetary drive. Continuous frequency coverage from 550 KC to 35 MC on 4 Bands, with electrical bandspread tuning and logging scales. Other features are RF gain control with AGC on-off switch—phone-standby-CW panel switch—prewound coils in a shielded turret assembly and copper plated chassis and shielding.

Uses 12BE6 mixer-oscillator, 12BA6 IF amplifier, 12AV6 detector-first audio, 12A6 beam power output, 12BA6 BFO oscillator, and 5Y3 rectifier. A lettered control plate is provided for the cabinet of your choice or you can order the optional Heathkit cabinet featuring the full size aluminum panel.

Phone—standby—CW panel switch.

RF gain control with AGC on-off switch.

Electrical bandspread tuning with logging scales.

RECEIVER CABINETS

Proxylon impregnated fabric covered plywood cabinet available for BR-2 and AR-2 receivers. Includes aluminum panel, flocked reinforced speaker grill and protective rubber feet.

For BR-2 Receiver, Cabinet 91-9
Shipping weight 5 lbs. \$4.50

AR-2 Receiver, Cabinet 91-10
Shipping weight 5 lbs. \$4.50

Heathkit FM TUNER KIT

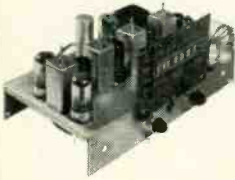

MODEL FM-2

\$22⁵⁰

Shpg. Wt. 8 lbs.

Here is an FM Tuner that can be operated with your Hi-Fi Amplifier or through the "phono" section of the ordinary radio. Completely AC operated to eliminate problems usually encountered in "economy type" AC-DC tuner circuits. Features 8 tube circuit with separate mixer and oscillator, 3 double tuned IF stages followed by a limiter discriminator providing maximum sensitivity and selectivity across the full FM frequency band of 88 MC to 108 MC. The tuning unit is factory assembled and adjusted, thus eliminating tedious critical "front end" alignment problems. The attractive slide rule dial and vernier tuning combine to make the Heathkit FM-2 Tuner simple to operate.

Heathkit BROADCAST BAND RECEIVER KIT



MODEL BR-2

\$17⁵⁰

(Less Cabinet)

Shpg. Wt. 10 lbs.

The Model BR-2 Broadcast Band Receiver is designed especially for the beginner without any sacrifice of quality. This receiver features a transformer operated power supply, high gain miniature tubes, sharply tuned IF transformers, new rod type built-in antenna, and a trouble-free planetary tuning system. Exceptional performance with unusually high sensitivity, good selectivity, and excellent tone quality from the 5½" PM chassis mounted speaker. Can be used either as a receiver, tuner, or phono amplifier. Uses 12BE6 mixer-oscillator, 12BA6 IF amplifier, 12AV6 detector, 12A6 beam power output, and 5Y3 rectifier.

HEATH COMPANY • Benton Harbor 20, Mich.

ORDER BLANK



MAIL YOUR ORDER TODAY TO THE
HEATH COMPANY
A SUBSIDIARY OF DAYSTROM, INC.
BENTON HARBOR 20, MICHIGAN

WALNUT 5-1175

From

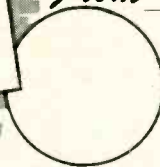

SHIP VIA

- Parcel Post
 Express
 Freight
 Best Way

(PLEASE PRINT)

QUANTITY	ITEM	MODEL NO.	PRICE

Enclosed find () check () money order for
Please ship C.O.D. () postage enclosed for _____ pounds.

On Express orders do not include transportation charges—they will be collected by the express agency at time of delivery.

ON PARCEL POST ORDERS include postage for weight shown. ORDERS FROM CANADA and APO's must include full remittance.

TELEVISION

Tommy also saw bursts on numerous occasions, too short and erratic for identification.

Raymond Sloss, Baton Rouge, La., reports a jumble of stations, 6:30 to 8 pm, Jan. 4, with WBBM-2, Chicago; WBAY-2, Green Bay, and WTMJ-4, Milwaukee, Wis., and KOA-4, identified. Raymond also had good Western reception Jan. 31, 5:30 to 7 pm, logging KOB-4, Albuquerque, N. M.; KPHO-5, Phoenix, Ariz.; KMID-2, Midland, and KROD-4, El Paso, Tex.

On Feb. 1 Art Collins, Buffalo, N. Y., caught WOW-6 and KMTV-3, Omaha, Neb.; WOI-5, Ames, Iowa; KFBC-5, Cheyenne, Wyo.; WKY-4, Oklahoma City, and KCKT-2, Great Bend, Kans., mostly very strong and steady, for three hours, beginning at 4:30 pm.

We report these individual loggings in detail to show the considerable extent of the midwinter dx. There was plenty more in the latter half of December. Viewers who think that early summer is the only time that dx is worth bothering with are missing more than they know!

Over 50 TV dx club

In the summary of TV dx for 1954, printed in the February issue, we started listing the standings of observers who have reported totals to us. Membership in the "Over 50 Club" is bound to grow. If you want to join, send us your total of stations received (positively identified by yourself; verifications not required). If you have a u.h.f. receiver, record the number of u.h.f. calls. Give the call of the most distant station you've logged; and if you photograph identifications, let's have your photo record, too. Here are changes and additions since the 1954 summary was prepared.

NAME	LOCATION	TO-TAL	BEST DX
Bedford Brown, Jr.	Hot Springs, Ark.	176	
Louis Matullo	Washington, Pa.	149	
F. E. DeGroat	Salamanca, N. Y.	94	
Robert Weems, Jr.	State College, Miss.	110	
Tommy Larkins	Clarkville, Tenn.	70	
New Members			
Skipper Easter	Vinton, Iowa	95	
Sam Brooks	Boston, Ga.	90	
Edward Fournier, Jr.	Bradford, R. I.	64	1,500
Tommy Mayo	Boston, Ga.	54	
Larry Whiting	Ilderton, Ont.	53	1,500

In the above summary, 19 of the 149 stations logged by Louis Matullo were in the u.h.f. range. In addition, 113 of the stations were photographed. This is really a comprehensive report and worthy of particular commendation. Let's have more of these. END

Implosion, It Was

by Jeanne DeGood

"A picture tube will not explode," Boastful, Careless Charlie crowed, And then I waved the guy goodbye As he went by me—flying high.

Gives your customers brilliant results ...pays off for you!

NEW SONOTONE 1P CERAMIC CARTRIDGE

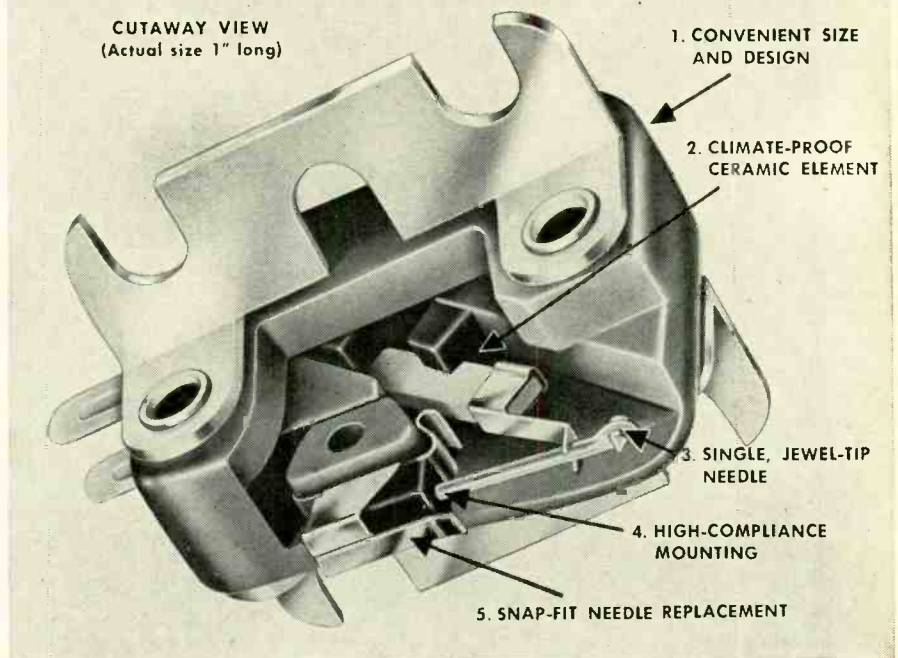

1. Easy to install. Just two models fit most arms now in use. Cartridge is less than 1" long, 8/10" wide with bracket. Time-saving hardware included.
2. Ceramic element gives flat response (see curve) —requires no preamplification or equalization. No deterioration problems as with other

- types...virtually immune to hum pickup.
3. Replaceable needle, diamond or sapphire. Models for 33-45 rpm, or 78 rpm.
4. Extreme lateral compliance and low-mass design give superior tracking, low wear.
5. Needles snap in, snap out easily.

Tap the Huge 33-45 RPM Replacement Market!

Install this new Sonotone 1P, and give your customers exciting, true, wide-range response. At one stroke, you make a good sale, cut installation time, avoid problems found with other types of cartridges...and build your reputation for quality work and professional advice. No other cartridge has all the advantages this 1P gives you! With sapphire, \$8.50; with diamond, \$30.

RESPONSE 30-15,000 ± 3 DB!

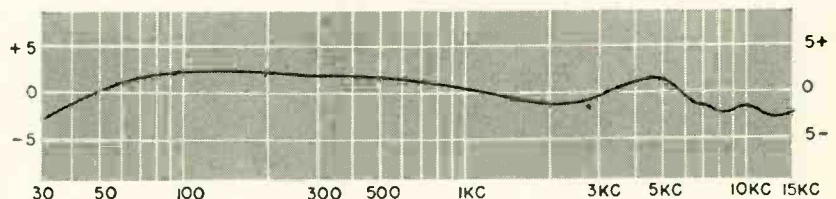

Response to new industrywide RIAA characteristic shows how 1P ceramic cartridge *self-equalizes*, because it works on "amplitude" rather than "velocity" principle. Here's startlingly improved performance for your customers' phonos!

SONOTONE CORPORATION

ELMSFORD, N. Y.

Write Dept. CE-45 for free Phono Modernization Manual

TELEVISION ... it's a cinch!

By E. AISBERG

From the original "La Télévision? ... Mais c'est très simple!" Translated from the French by Fred Shunaman. All North American rights reserved. No extract may be printed without the permission of RADIO-ELECTRONICS and the author.

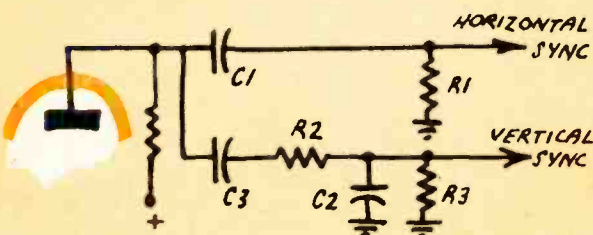
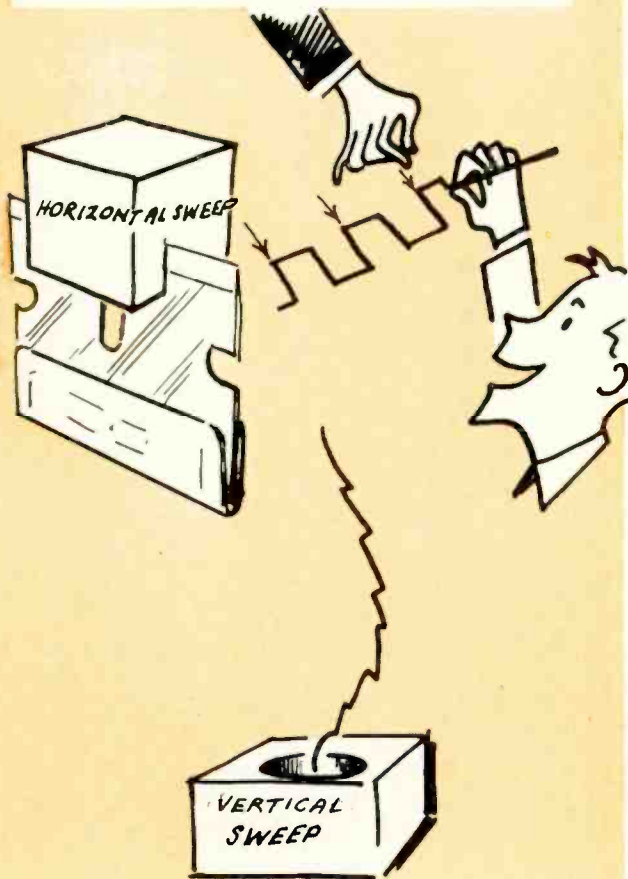
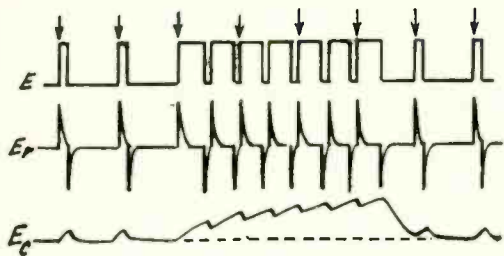

Fifteenth conversation, third part: Differentiation and integration in action, effect of the time constant

KEN—When worse comparisons are pulled, you'll pull 'em! Only remember what we've just said—that the same circuit can be an integrator or differentiator, depending on whether the voltage is taken across the resistor or the capacitor. In a differentiator circuit R and C should be fairly small, so their product—their time constant, in other words—won't be greater than about one-fifth the duration T of the pulse. But R and C should both be much larger in an integrator circuit, so the time constant is several times longer than T.

WILL—So, even if you do use just a resistor and a capacitor for either a differentiator or an integrator circuit, the circuits really are different, since you choose different values. But I still don't see just what you do with them.

KEN—You should by this time. Draw the form of a sync signal as it comes out of the separator.

WILL—Here's a nice row. First we have two horizontal pulses, then the longer vertical ones, then line pulses again.

KEN—Now let's mark the points where the horizontal sweep oscillator is triggered. Remember how we found that the horizontal sync had to be maintained throughout the vertical sync pulse? Now do you think you could show how those signals would look if they were differentiated?

WILL—According to what you've just said, the time constant should be very short—less than one-fifth the duration of the pulses—which pulses?

KEN—The shortest ones—the horizontal pulses.

WILL—Well, we get very sharp, narrow differentiated pulses, positive or negative according to whether they are at the beginning or end of the pulse.

KEN—Those razor-blade signals are perfect for synchronizing the lines. Now try to draw the signals coming out of an integrator.

WILL—H'm, this circuit must have a time constant quite a bit longer than the duration of the pulse. But we won't get much of an output pulse from it! The capacitor just starts to charge when the voltage is removed and it starts to discharge again.

KEN—All the better, Will. If you can't find the horizontal pulses in the output of the integrator, you're doing well. Notice how the circuit reacts when the vertical pulses come along?

WILL—They last a little longer, so the capacitor has a chance to charge up a little more. But it discharges a little between the first and second pulses. Then during the second pulse it charges up some more. Then there is another little discharge, another bigger charge, and so on. Each charge ends up with a little more voltage on the capacitor, and the whole picture looks something like a set of steps.

KEN—With this difference: as the voltage rises, the steps become shorter.

WILL—That exponential law again! But everything has to come to an end. And when the train of vertical pulses stops, the capacitor discharges, giving you another perfect exponential curve.

KEN—Not quite perfect, Will, because it gets little jolts from the horizontal pulses following . . .

WILL . . . so because of our integrator circuit, the whole group of vertical pulses begins to look like a long sawtooth where the line pulses practically disappear, leaving only insignificant jags along its top. Now what are we going to do with this integrated voltage?

KEN—You apply it to the vertical time base and, if you have luck, these pulses will synchronize it perfectly. If you want to refine the circuit further, you can use a biased diode to smooth off the rough edges and pass only the voltage peaks. But that's not necessary. You can have a very simple selector circuit in which the voltage across the

separator load resistor is applied to a differentiator circuit C1-R1 which goes to the horizontal circuits and also to an integrator circuit R2-C2 which is connected to the vertical oscillator.

WILL—And how about C3 and R3?

KEN—C3 is a coupling capacitor that keeps B plus out of the time-base circuits. And R3 is a grid resistor.

WILL—But won't C3 and R3 constitute themselves a sort of differentiator that will disturb the integrator action?

KEN—Don't worry—you can choose their values so they have an insignificant differentiating effect.

Exponential ladder

WILL—Why did you say "if you have luck" when you spoke of synchronizing the vertical sweep circuit?

KEN—Oh, I have no love for those integrator circuits. The vertical signal isn't neat—it has no shape! Give me differentiators, where the signal appears at full amplitude the precise instant you need it!

WILL—Yes, but you can't use a differentiator to build up your vertical pulse!

KEN—Why not? Suppose I just use a capacitor and resistor large enough to give me a time constant a lot longer than that of the horizontal pulses?

WILL—I don't see how that would work. Can you help me out with a drawing again?

KEN—O.K. Let's take negative-going pulses this time. Can you draw the voltage across the resistor?

WILL—Let's see. At the instant the negative line pulse appears, the whole voltage is across the resistor. The charging current that produces it decreases slowly, because the time constant is long, and . . .

KEN—But, my young friend, the charge isn't going to have much time to decrease, because the horizontal pulse itself isn't going to last very long.

WILL—Exactly. After the commencement of the charge, the drop of voltage across the resistor diminishes slightly, then returns to zero at the end of the pulse.

KEN—Are you absolutely sure of that? When the applied signal drops back to zero, it rises E volts. But, since after the beginning of the charge, the voltage on your capacitor has already risen a little toward zero, as you can see from the tips of the first two pulses, it reaches a slight positive value at the end of the pulse. Then the capacitor discharge starts bringing it back toward zero again.

WILL—How complicated can this "most simple" circuit get?

KEN—It's a little simpler than it looks at first glance. You can easily see how the action gets you your vertical field pulse.

WILL—The principle seems to be the same as for line pulses. But the charge lasts a little longer for each individual pulse. And at the end of each, in rising E volts, the voltage across the resistor becomes more and more positive because the capacitor hasn't had time to discharge in the short interval between two successive vertical pulses.

KEN—And the voltages again form a sort of steep stairway . . . ?

WILL—Exponential, I'm sure! And this lasts till the end of the vertical pulses. Then the capacitor can heave a sigh of relief and start discharging.

KEN—You see how our long time constant differentiator has succeeded in making the vertical pulses into a series of impulses that rise till they dominate the countryside, figuratively speaking. Now what do we have to do to use them?

WILL—I guess that if you clipped off everything outside the two dashed lines, you'd get the voltage pulses you've marked E_s . Then you'd use them to synchronize the vertical oscillator.

KEN—Isn't that much neater than the integrator approach? The very first pulse—there, where I've put the arrow—triggers the vertical time-base precisely.

WILL—Ah, well, this timebase I wear on my wrist indicates that it's time for me to go to bed and try to integrate your differential explanations!

TO BE CONTINUED

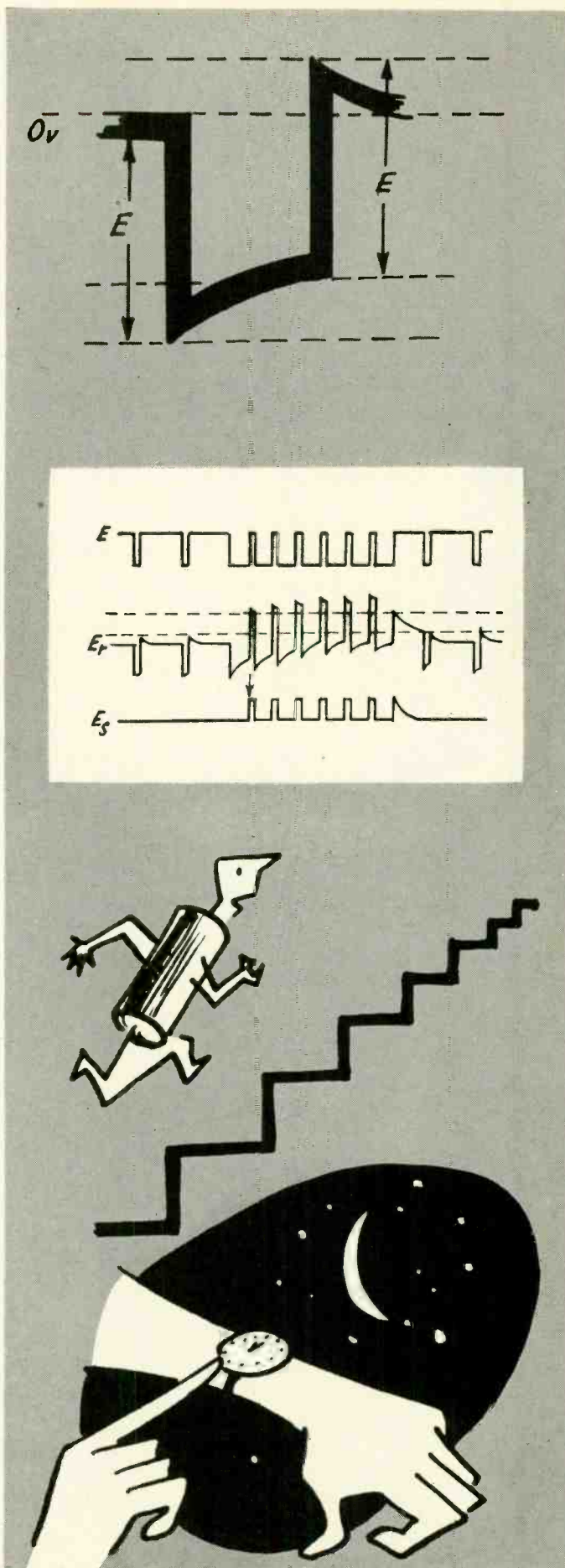

NAME Olson, D.R. TELEPHONE Lex. 4310 SET G.E. Model 910
 ADDRESS 44 Beaver St. CHASSIS 17C110
 Clearance and Remarks

Trouble Report			Visit	Made	Trouble	Diagnosis
Date	Time	Complaint	Promised			
4/28/2	3:10p	Pic too small	10am	10:15a		Replaced vert. outp. tube. Vert. height control near max - <u>check</u>
7/6/2	10:15a	"	3:30p	4:00p	"	Repl. open cathode bypass C. on Vert. Outp.
3/7/3	9:45a	Sound Weak	9:00a	9:00a	Audio	Repl. 6K6

Date	Hours		Charges			Bill Sent	Payments		Statement Sent	Current Balance
	Home	Shop	Service	Labor	Parts		Date	Amount		
4/28/2	3/4	-	3.00	1.00	2.65	Cash	-	-	-	-
7/6/2	1/4	1/2	3.00	9.00	1.30	8/1	8/8	7.00	9/1	6.30
3/7/3	1.	-	3.00	1.00	2.80	Cash	-	-	-	-

an INDIVIDUAL TV SET TROUBLE RECORD

By HENRY A. AHNEMANN

*Improve customer relations
and business efficiency
with simple system*

YOU'VE a lot of faith in the family doctor because he knows every detail of your medical history. If he doesn't actually remember everything, it's all there in his very complete record—complaint, diagnosis, treatment and results—what, when, where and how. Let's see how a similar record can be kept by a service technician and what could be gained from it.

You make a call on a particular customer. We'll assume it is a simple job and that the trouble is cleared by replacing the vertical output tube. The job is handled quickly and efficiently, the charge is nominal, good relations are established and you probably have a new steady client. You notice that the vertical height control is set pretty close to its maximum range. Perhaps another trouble was covered up by the new tube. But, you are busy, the set performs well, and you let it go at that.

A month goes by; you get another call from the same customer and the

complaint is the same. During this time you've handled lots of calls and the details of what you found on your first call are rather hazy. The customer undoubtedly will remind you that you were there for the same trouble just a short time ago, but where you do need help your customer won't be of much assistance. However, if you have a record of what you did and noticed on the previous visit, you are in a position to do the job properly. If you find that a new tube again fixes things, you are justified in suggesting that a more careful bench check of the set be made and your records support you and help to explain the situation to the customer. If the customer does not agree, you are protected when the inevitable follow-up call comes along.

Here, then, is the first big advantage of an individual trouble record for each set you service. Your memory is prompted and you are prepared to make your service efficient by supplementing

your initial call with constructive work rather than repeating the same jobs. A brief glance at your card while you are making your call will tell you how the set has been performing, how frequently calls have come in and whether there is a possibility that you are overlooking something.

The record can be simple. In fact, the simpler it is the easier it is to maintain. As illustrated, it may be prepared on a 5 x 8 library card and the headings chosen to make it as versatile as you desire. Other jobs that a trouble record can make easier for you are suggested in the following:

Mrs. Olson calls in saying her picture is very small; the sound is fine. While getting the report from her, you reach for the record for this set. On your first call you have entered the information shown on the top of the card illustrated. So you promptly reply, "O.K., Mrs. Olson, our man will be there about 10 A.M. Let's see, you're at

150 field tests have proved to
WARD jobbers:

- * Good VHF picture at as far as 200 miles on several channels
- * Excellent results at 100 miles
- * Good results in areas where no other antenna was able to bring in a picture
- * More compact—25%-75% less stacking distance
- * Channel 2-13 response as much as 40% better than any comparable antenna
- * Unique superior snap-lock bracket
- * Original WARD design all aluminum supplemented spring pressure bracket—eliminates possibility of intermittent contact

TRY ONE—you'll find why the Invader is superseding all fringe and super-fringe antennas.

WARD Model TVS 356 2 bay and stacking harness \$39.95 list

WARD Model TVS 357 4 bay stacking kit (feed harness only) \$3.95

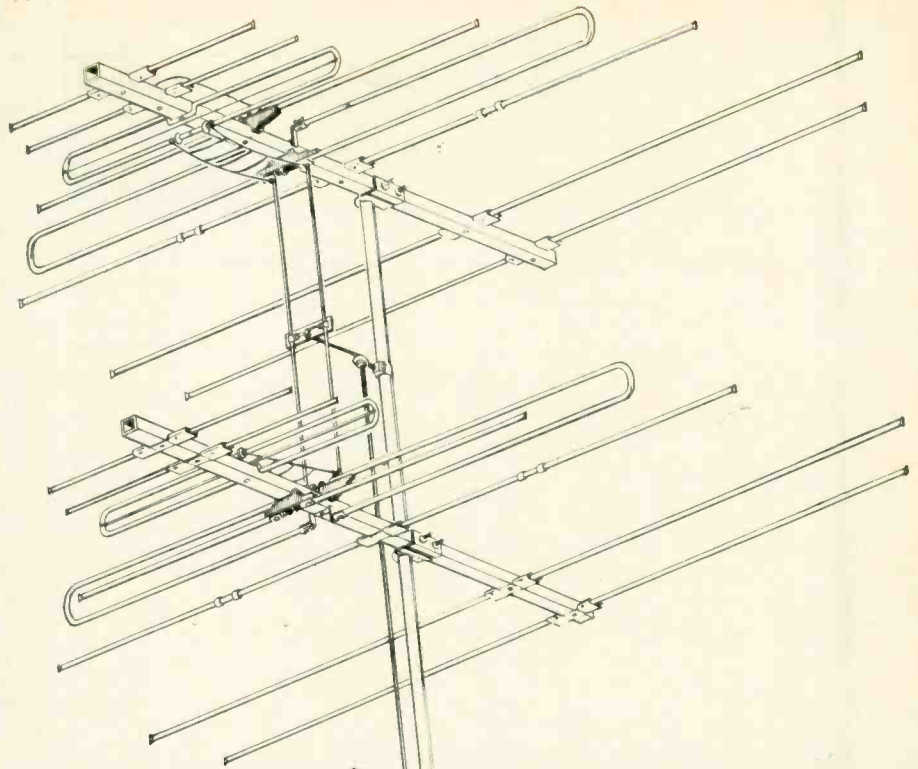

THE INVADER* CONQUERS

sweeps all other fringe and super-fringe antennas before it

*an original WARD design

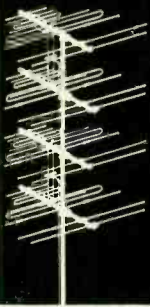

flat type Uni-plane Yagi for fringe area VHF and primary signal area UHF.

*Documental testimonials in our files



WARD

Products Corp., Cleveland 15, Ohio

TESTED AND PROVEN TELEVISION

E-Z WAY TILT OVER TOWERS

E-Z Way TV Towers crank up and down. Can be easily lowered and the antenna tilted over to a height of only six feet above the ground and made absolutely hurricane proof!



- CRANKS UP AND DOWN ● TILTS OVER
- NO GUY WIRES—NO CONCRETE
- NO ROOF DAMAGE
- NO LIGHTNING RISK ● HURRICANE PROOF
- GREATER DISTANCES—CLEARER PICTURES

The only practical free-standing tower is one that can be lowered in case of strong winds. E-Z Way Tower is the sturdiest, most unique and versatile tower in the industry. High-test steel construction. Electric Arc welded. Each section completely immersed in Pliotite S-5 (rubber base) aluminum enamel for long-lasting weather resistance. Most economical. Easiest to install. Easiest to service and add antennas. Twelve tilt-over types from 30' to 85' VHF heights. Fifteen building-attached crank-up types of towers. Each tower specifically designed for a particular use.

DISTRIBUTOR INQUIRIES INVITED

FOR FREE CATALOGUE AND INFORMATION WRITE:

E-Z WAY TOWERS, Inc.
5901 E. BROADWAY • P. O. BOX 5491 • TAMPA, FLORIDA

THE FINEST OUTPUT TRANSFORMERS

Acrosound Ultra-Linear[★]



TO-330 Transformer for high powered high fidelity circuits

- ✓ ± 1 db 10 cps to 100 kc
- ✓ Over 50 watts clean at any frequency 20 cps to 20 kc
- ✓ Makes the finest amplifier obtainable using pp par KT66's or pp 6550's
- ✓ \$39.75 net at leading distributors everywhere

FOR LOWER POWER ULTRA-LINEAR CIRCUITS

- TO-300 for Ultra-Linear Williamson Circuits. **\$24.75**
- TO-310 for Ultra-Linear operation of 6Y6 tubes. **18.75**
- TO-320 for Ultra-Linear operation of 6Y6 tubes. **18.75**

Send for FREE 16 page booklet which tells why ACRO ULTRA-LINEAR is the best. Contains 7 full pages of the finest high fidelity circuits available.

Prices slightly higher in the West

ACRO PRODUCTS CO.

369 SHURS LANE, PHILADELPHIA 28, PA.

44 Beaver Street, are you not?—and you have a G-E console? Good. Now if we can't meet that appointment, we'll call you. Your number is Lexington 4310, isn't it?"

The effect on your customer? It's bound to make her feel that you really are on your toes. And if you take a minute to mention that it's been nearly 8 months since she had trouble, what further evidence does she need of your personal interest in her set? And that minute you spend on good relations isn't an added minute. It's a minute you have saved by not having to again copy down name, address, phone number and the rest.

Another little detail. When you make that first call, record the model number and other details. Check to see if you have that schematic in your file. If you haven't, get it at the first opportunity—it may help get the set into service a day earlier on the next call than if you had to stop to get it. Before you go on a call, take a look at the diagram. It may save you a trip back to the shop for a tube you do not normally carry.

How about measuring your costs, time and net profits? How long is the average service call? How long does it take to clear the average bench job through the shop? Is your service charge adequate to cover this time—can it be reduced to meet competition? How well are you meeting time commitments to customers? What is the average out-of-service time and can it be improved? What's the percentage of call-backs within 10 days? 2 weeks? Does it look as if a little skull session on some techniques or on a particular type of set would pay dividends? These questions and others can be answered if the proper information is entered on the record and a summary prepared. These answers are important for they tell how well you are controlling your business. Once a month is probably often enough to go over the cards and make up a tabulation of the items that interest you. Probably the best time to do this is when you are making your monthly statements.

Speaking of statements—the back of the record card can also be put to good use. As shown in the illustration, a record can be prepared with a few headings that will show hours spent in the field and in the shop, charges for labor and parts and a record of payments. The whole story is on a 5 x 8 card and—if it gets filled up—a couple of strips of cellulose tape applied in the form of hinges, are all that is necessary to attach another card and extend the record.

Finally, don't overlook the advantage of letting your customers see the record. They're sure to be impressed with the detailed information you have about *their* set and they're that much more certain to call you since you are the *one guy* who really knows their set. It may take a little time to organize and set up, but, once its done, the trouble record will pay off. **END**



...from start

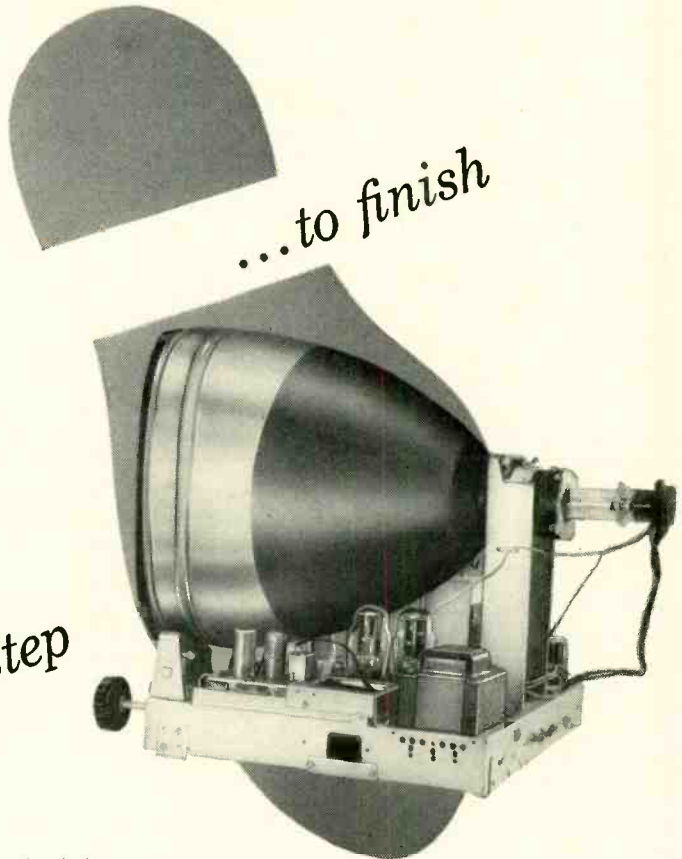

...to finish

...and step by step

Become a top-notch television service technician

Now . . . RCA INSTITUTES offers modern TV KIT with Comprehensive Television Servicing Course

START to build with a TV Kit developed by one of America's foremost radio-tv schools—RCA Institutes. LEARN with simple step-by-step instruction how to build a modern, large-screen receiver. TEST each stage, as you build, and see how it works. Learn how "trouble-shooting" is applied. FINISH your Home Study Course ready and able to service all make and model sets!

Easy-to-follow instructions are planned and prepared for you through the efforts of RCA Institutes' instructors, engineers at RCA Laboratories, and training specialists of the RCA Service Company.

The RCA Institutes' TV Kit utilizes up-to-date circuits including:

- *Synchro-Guide horizontal automatic frequency control circuit.*
- *Horizontal magnetic reaction scanning.*
- *Latest deflection circuits.*
- *FM sound discriminator.*
- *High-gain, low-noise cascode tuner.*

Join the many thousands who have been successfully trained by RCA Institutes for a good job (or business of their own) in television servicing.

BASIC KNOWLEDGE OF RADIO NECESSARY
NO NEED FOR PREVIOUS TV TRAINING

FREE BOOKLET! MAIL COUPON NOW.

RCA INSTITUTES, INC., Home Study Dept. ER-455
350 West Fourth Street, New York 14, N.Y.

With no obligation on my part, please send me a copy of your booklet on the TV Servicing Home Study Course and Kit. I understand no salesman will call.

Name: _____ (Please print)

Address: _____

City: _____ Zone: _____ State: _____



RCA INSTITUTES, INC.
A SERVICE OF RADIO CORPORATION of AMERICA
350 WEST FOURTH STREET, NEW YORK 14, N.Y.

Testing Ion Trap Magnets

By JAMES A. McROBERTS and ELLIOTT A. McCREADY

*Checking field strength with
compass and oscilloscope*

TESTING ion trap magnets in the average shop is limited usually to substituting one magnet for another and observing picture tube performance. This procedure is a very satisfactory method of testing anything—even the kisses of the girl friend.

But perhaps the proper substitute is not available and after purchasing a new magnet, it is found that the original unit is not defective. Time is wasted, and the customer irritated. The simple tests described in this article will indicate the strength of an ion trap magnet (or any magnet).

Wooden magnetometer

A yardstick made of wood (or other nonmagnetic material) and a pocket compass make up the entire bill of materials.

Place the compass on one end of the yardstick (Fig. 1) in a region free of interfering magnetic fields. Move the ion trap magnet being tested from the opposite end of the yardstick, toward the compass (Fig. 2). When there is a measurable deflection on the compass, record the distance from the center of the compass to some point on the ion trap magnet. Use a 10° deflection as a reference.

Any magnetic field acting on the magnetic field of the compass needle will cause it to deflect. The influence of a magnetic field varies inversely as the square of the distance from it. For example, a magnet 5 inches from the compass will produce as much deflection as a magnet 6 inches from the compass, if it is 25/36 as strong.

If you test good magnets as they come into the shop, you will soon collect the needed data on all types of ion trap magnets so that whenever you have a suspected one it will not be difficult to test it immediately and thoroughly.

Be sure to set up the equipment in an area free from magnetic fields. To do so, rotate the compass at the end of the yardstick until the needle points to zero. While keeping the compass fixed with respect to the yardstick, and the yardstick pointing constantly in one direction, move the yardstick in a 6-inch radius circle around its original position. If the needle is deflected more than

Fig. 1—Basic setup for testing magnets.

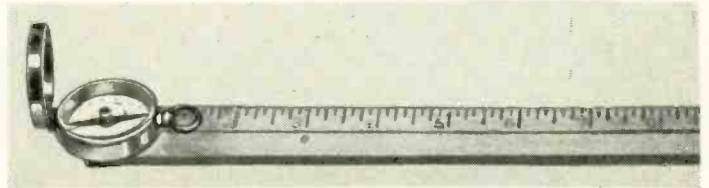

Fig. 2—Magnet is moved toward compass.

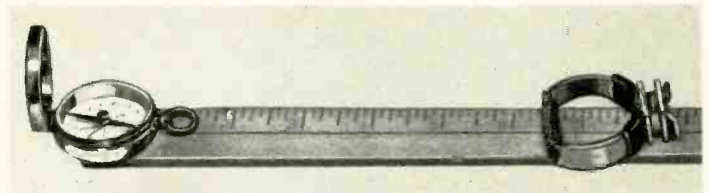

Fig. 3—Scissors forms magnetic shunt.

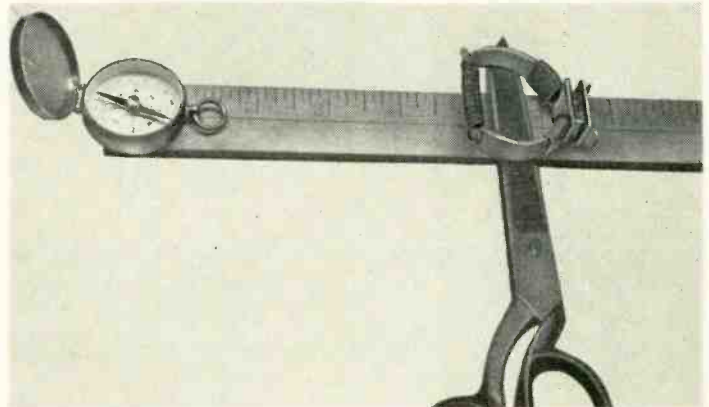
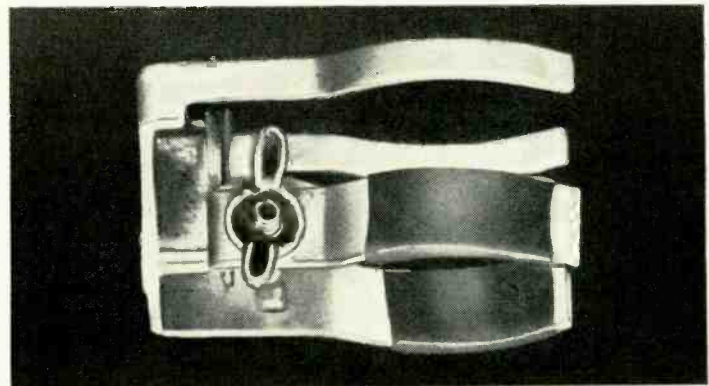

Fig. 4—Single magnet—double poles.



a few degrees, you will have to search elsewhere for a magnetic dead spot. As a precaution, also move the yardstick vertically. In an ideal position, the needle will maintain its alignment with the yardstick.

Take a good ion trap magnet and move it along the yardstick until a deflection is obtained—do not use over

about 20°. The trap in Fig. 2 causes 10° deflection when it is about 8¼ inches from the center of the compass. A small touch of cement holds the compass at exactly zero in this figure. If you wish, use the 1-inch line as the zero point. Note that the pole pieces of the trap point toward the compass; the back of the trap (away from the com-

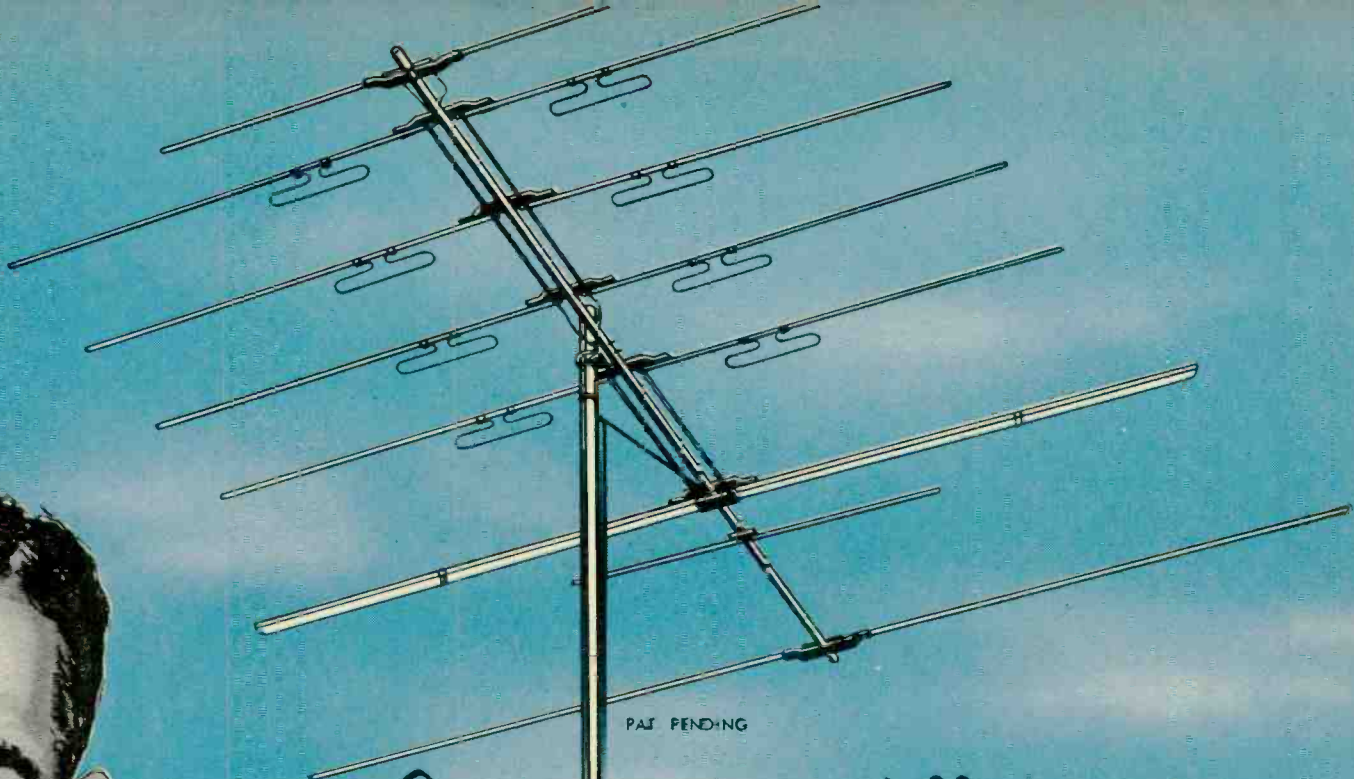
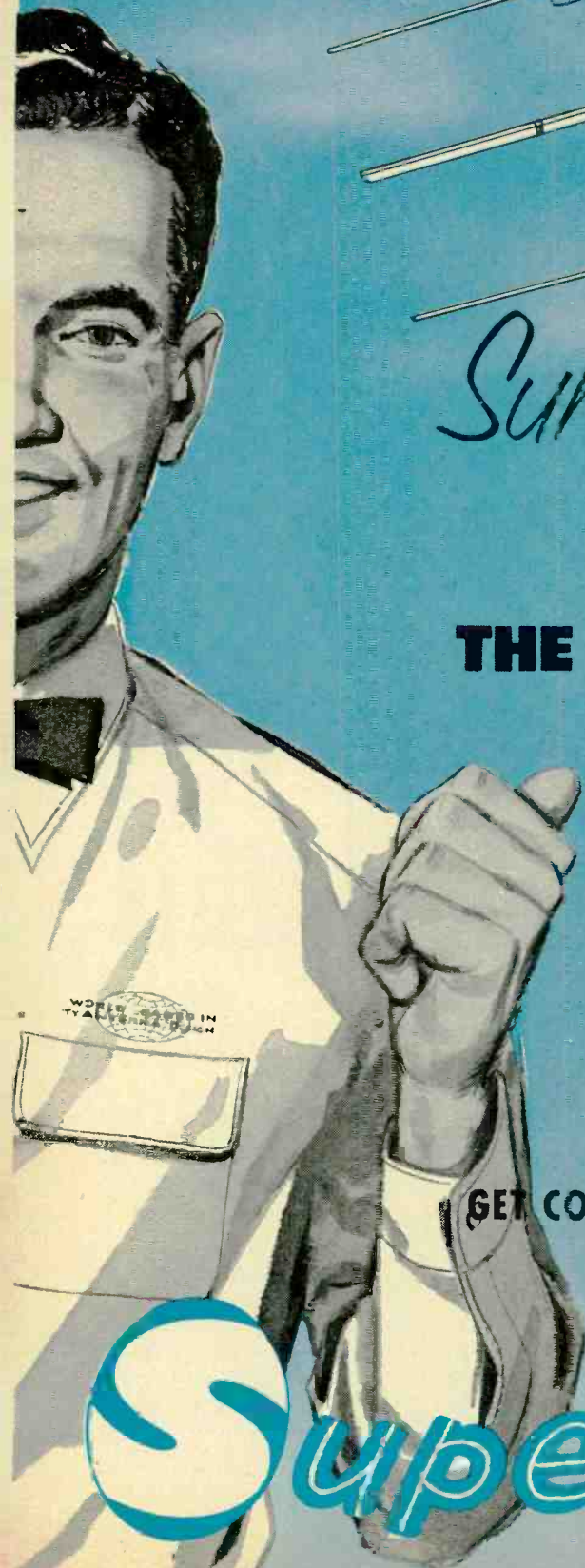

PAT. PENDING

*Sure it's different-
and better too!*

THE TACO SUPER TRAPPER

The fringe area antenna with single bay gain up to 15 db! Employs Penta-Phase principle (5 driven elements). Aluminum throughout, including phasing line channels. Radiating traps in 4 driven directors give 24 working elements on the high band. Unrivalled gain and front-to-back ratio will positively lick the toughest interference problem.

Single or stacked for fringe or sub-fringe problem areas. Completely factory assembled including transmission lines. Incorporates automatic spring lock assembly — characteristic of Taco's easy-up design.

WORLD LEADER IN
TV ANTENNA DESIGN



GET COMPLETE DETAILS FROM YOUR DISTRIBUTOR ON THE

New TACO

Super TRAPPER

TECHNICAL APPLIANCE CORPORATION, SHERBURNE, N. Y.

IN CANADA: HACKBUSH ELECTRONICS, LTD., TORONTO 4, ONT.

COPYRIGHT 1955

LEARN basic electricity basic electronics

THE EASY "PICTURE BOOK" WAY!



The fabulous new
ILLUSTRATED
Training Course
now used by
the U. S. Navy!

You Learn by Pictures

Over 25,000 Navy trainees have already learned Basic Electricity and Basic Electronics this easy, "Picture Book" way! Now, for the first time, YOU can master the basics of Electricity and Electronics with this same "Learn-by-Pictures" training course! Over 1,700 simple, easy-to-understand drawings explain every section—these "teaching" pictures actually make up more than half the entire course! No other Basic Electricity or Basic Electronics course in America uses this revolutionary illustrative technique! You learn faster and easier than you'd ever dream possible!

A Complete Idea on Every Page

Here's how this easy, illustrated course works: every page covers one complete idea! There's at least one big illustration on that same page to explain it! What's more, an imaginary instructor stands figuratively at your elbow, doing "demonstrations" that make it even easier for you to understand. Then, at the end of every section, you'll find review pages that highlight the important topics you've just covered. You build a thorough, step-by-step knowledge at your own pace — as fast or as slow as you yourself want to go!

Everyday English—A Course Anyone Can Understand

Sponsored by the Navy to turn out trained technicians in record time, this modern course presents Basic Electricity and Basic Electronics in a simple way that everyone can grasp—regardless of previous education! Every phase is made instantly clear—explained in plain, down to earth English—with hundreds of easy-to-understand illustrations to help you!

10 Complete Volumes

Vols. 1 and 2 of "Basic Electricity" cover DC components and circuits; Volumes 3 and 4 cover AC components and circuits; Volume 5 covers AC and DC motors and machinery.

Volume 1 of "Basic Electronics" covers Diodes & Power Supplies; Vols. 2 and 3 cover Amplifiers & Oscillators; Vols. 4 and 5 cover Transmitters & Receivers.

Home Study Without Correspondence

This course is so different, so complete—there's no need for the usual letter writing, question and answer correspondence! You learn at home—at your own pace!

10 Day Examination — Money Back Guarantee

Send today for these exciting new training courses—you risk nothing! When you receive the volumes, examine them in your own home for 10 days. If, at the end of that time, you're not completely satisfied, simply return the books to us and we'll gladly refund your full purchase price! Total cost for either 5-volume course is only \$9.00! In Canada, prices approx. 5% more.

ORDER TODAY!

These books are sold by electronics parts jobbers and book stores. If YOUR dealer doesn't have these books, mail this coupon!

JOHN F. RIDER PUBLISHER, INC.
480 Canal Street, N.Y.C.

Please RUSH me sets of "Basic Electricity" @ \$9.00 per set, and sets of "Basic Electronics" @ \$9.00 per set. I understand that I may return the books within 10 days and receive a complete refund of my full purchase price.

Name
Address
City & State..... E

TELEVISION

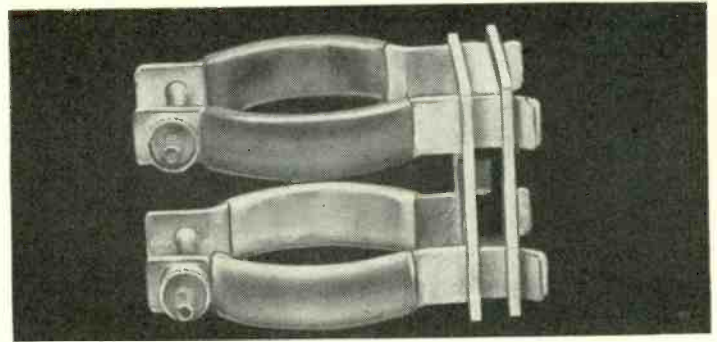

Fig. 5—Double magnet with double poles.

pass) serves as an indicator on the yardstick. The magnetic field of the magnet will produce maximum deflection in this position.

We can simulate a weak ion trap magnet by using the same unit and short circuiting the magnetic gap across the pole pieces with a magnetic material. An old pair of scissors will do (Fig. 3). Now let's try the strength of the magnet on the test rig. You will find that you must move the trap closer ($6\frac{1}{8}$ inches) to the compass to get the same deflection as obtained previously.

Taking the data from this experiment, square $6\frac{1}{8}$ and divide it by the square of $8\frac{1}{4}$. This gives us about 0.64 or 64%. The single shunt of the scissors has reduced the energy of the magnetic

comparison standards. Be sure your standards are O.K.! Even new magnets may not be what they are rated. Before condemning a magnet as being too strong or too weak, check the C-R tube manual for the correct ion trap field strength. When you have found the required strength, you can be doubly sure by using the correct standard as a temporary substitute.

Take care of PM ion trap magnets. They can be permanently damaged by improper handling or storage. A severe jar or striking it with a metal tool can cause the unit to lose its magnetism and its ability to focus the electrons. Always use a brass or nonmetallic screwdriver when adjusting variable magnets. When storing, do not leave

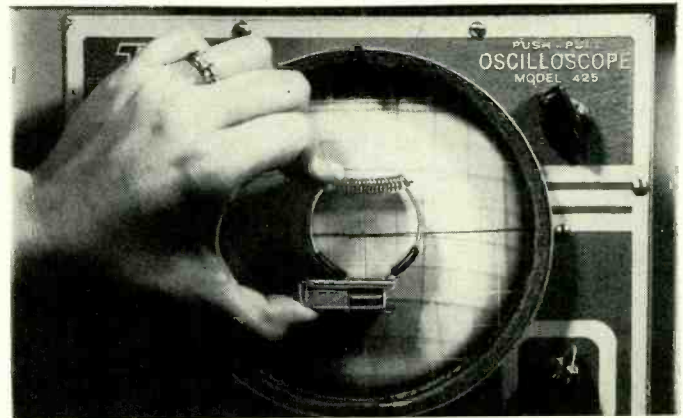

Fig. 6—Positioning the single magnet.

field 36%. Comparative testing of good and bad magnets indicates that a field strength loss of about 30% will result in a very decided loss of brilliance, with a noticeable loss beginning at about 25% of the optimum value. The ratio of the square of the distance from the compass of a suspected trap to that of a good trap should not be less than 0.7. For example, given 5 inches and 6 inches, squaring gives 25 and 36, and dividing 25 by 36 yields 0.695 which is just on the borderline of being bad. Such a trap should be replaced as it will result in a call-back soon, and the picture will be improved by a new trap.

The strength of ion trap magnets required for proper operation of modern picture tubes varies from about 20 to 50 gauss so you should obtain magnets with strengths of 23, 34, 40, 45 and 50 gauss and keep them on hand as

PM ion trap magnets in contact with each other, with metal tools or metal shelving.

Double magnet traps

Now Figs. 2 and 3 show the single pole piece (rather, pair of pole pieces) magnet. The other types are checked similarly. The pole pieces should always point to the compass when placed on the yardstick. Fig. 4 shows a single magnet type with double pole pieces; Fig. 5, a double magnet type with double pole pieces. It requires a different test.

Place either magnet down, the blue one (black or darker in the photo) is on top. Make the same test as for the single magnet type. Now turn the ion trap magnet upside down so that the blue pole piece is on the bottom. The same amount of deflection should be observed, but in the opposite direction

P. R. MALLORY & CO. INC.
MALLORY
APPROVED PRECISION PRODUCTS

P. R. MALLORY & CO. INC.
MALLORY
APPROVED PRECISION PRODUCTS

P. R. MALLORY & CO. INC.
MALLORY
APPROVED PRECISION PRODUCTS

THERE IS NO SUBSTITUTE

P. R. MALLORY & CO. INC.
MALLORY
APPROVED PRECISION PRODUCTS

All FP Capacitors are Mallory. There are imitations, but no substitutes. Only Mallory FP Capacitors have these features . . . developed by Mallory and accepted for years as the industry's standard of performance by manufacturers and service men:

- Genuine fabricated plate anode
- 85° C. temperature rating
- Long life on the shelf and in service
- High ripple current capacity
- Simple, speedy twist-prong mounting

Don't settle for anything less than the best. Always specify Mallory FP Capacitors by *brand*. They outperform all others . . . yet cost no more.



BE SURE TO USE...



Mallory Plascaps® . . . plastic tubular replacements with permanently secured leads . . . won't short out or open prematurely.



Subminiature Silverlytic* Capacitors . . . only $\frac{3}{32}$ " long and $\frac{1}{32}$ " in diameter . . . ideal for transistor and other miniature low-voltage circuits.

*Trademark

P. R. MALLORY & CO. INC.
MALLORY

CAPACITORS • CONTROLS • VIBRATORS • SWITCHES • RESISTORS
RECTIFIERS • POWER SUPPLIES • FILTERS • MERCURY BATTERIES
APPROVED PRECISION PRODUCTS

P. R. MALLORY & CO. Inc., INDIANAPOLIS 6, INDIANA

P. R. MALLORY & CO. INC.
MALLORY
APPROVED PRECISION PRODUCTS

P. R. MALLORY & CO. INC.
MALLORY
APPROVED PRECISION PRODUCTS

P. R. MALLORY & CO. INC.
MALLORY
APPROVED PRECISION PRODUCTS

these are the books that
SAVE TV SERVICE TIME

NEW
VOL. 5

HOWARD W. SAMS'

"Television Tube Location Guide"

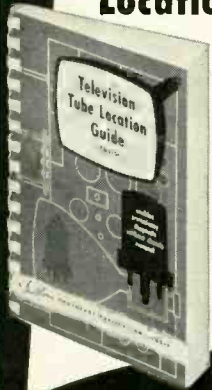

latest volume in this invaluable series of "Tube Location Guides"

FIND THE TROUBLE—REPLACE TUBES WITHOUT REMOVING THE CHASSIS

Latest volume in the series used daily by thousands of TV technicians. It's the only book that shows the *position and function* of all tubes in hundreds of recent TV sets. Helps save your servicing time. Most often, an operational check of the set in the customer's home gives you the clue to the trouble. Generally, a tube failure is the cause. This handy Guide makes trouble diagnosis and tube replacement fast and easy, *without removing the chassis!* Each TV model has its own clear, accurate tube placement diagram. All new diagrams covering 1953 and 1954 TV models. Over 200 pages. Indexed for fast reference; 5½" x 8½"; handy "open-flat" plastic binding. Pays for itself on just one job.

ORDER TGL-5. Only.....\$2.00



OWN THEM ALL—THEY HELP YOU EARN MORE

VOL. 4. Shows location and function of all tubes in hundreds of 1951-1952 TV models. 192 pages. 5½" x 8½". Fully indexed for quick reference.

ORDER TGL-4. Only.....\$2.00

VOL. 3. Gives tube positions in hundreds of 1950-1951 TV sets. Solves tube failure troubles in minutes. 192 pages; 5½" x 8½".

ORDER TGL-3. Only.....\$2.00

VOL. 2. Includes hundreds of tube placement charts for 1949-1950 TV models. Big, legible charts. 208 pages; 5½" x 8½".

ORDER TGL-2. Only.....\$2.00

VOL. 1. Shows location and function of tubes in TV models made in 1948-1949. Not duplicated in other volumes. 208 pages; 5½" x 8½".

ORDER TGL-1. Only.....\$2.00

Carry Them All in Your Tube Caddy

HOWARD W. SAMS & CO., INC.

Order from your Parts Jobber today, or write to HOWARD W. SAMS & CO., INC. 2205 E. 46th St., Indianapolis 5, Ind.

My (check) (money order) for \$..... enclosed. Send the following books:

- TGL-5 (\$2.00) TGL-4 (\$2.00)
- TGL-3 (\$2.00) TGL-2 (\$2.00)
- TGL-1 (\$2.00)

Name.....

Address.....

City.....Zone.....State.....

(priced slightly higher outside U.S.A.)

TELEVISION

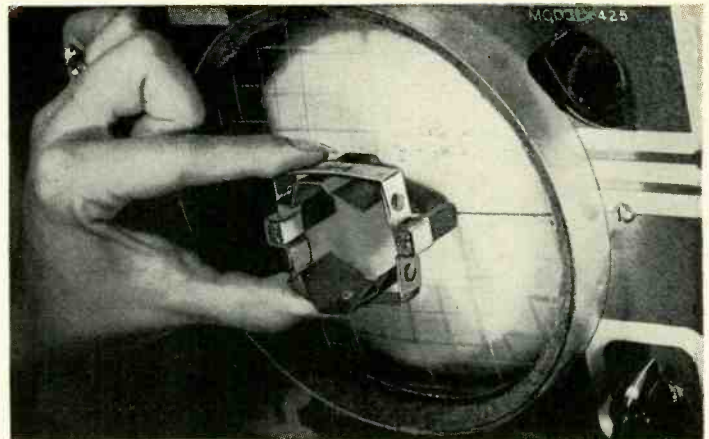

Fig. 7—Positioning the double magnet.

since the magnetic field of the magnet has been reversed. If over ½ inch of movement is required to obtain equal deflections, the magnet should be replaced.

Ring type magnets are tested in the same manner as the open-ended variety with one exception. Bring the magnet near enough to the compass to deflect the needle, and turn it for maximum deflection. The position thus found is maintained during the movement along the yardstick. The position which produces a maximum distance for any type magnet is the one that should be used.

Reject magnets which have to be moved more than 2 inches closer to the compass for standard deflection.

Turn the oscilloscope on, set the vertical gain to zero, and adjust the horizontal gain so the trace covers the width of the screen. Then adjust the vertical positioning control so that the horizontal trace coincides with the center horizontal line on the grid covering the face of the scope tube.

Place the ion trap magnet (Figs. 6, 7) to be tested against the scope tube face so that the field of the magnet is in the same plane as the scope tube face and parallel to the horizontal trace. The result will be a loop in the horizontal trace (Fig. 8). Reversing the ion trap magnet inverts the loop. The height of this loop will depend on the oscilloscope anode voltage, positioning of the ion trap mag-

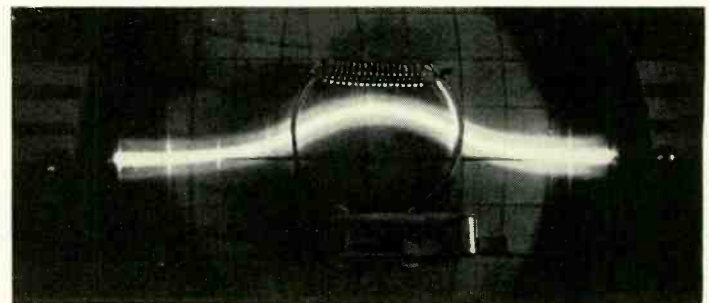

Fig. 8—Deflection produced by magnet.

net with suspicion magnets which require more than 1 inch movement. (Check your compass needle and some good and bad traps for the reject standards, as the magnetic strength of the needle may influence the distance somewhat.) Look down on the needle directly when making readings. A small magnifier may help to read accurately.

Oscilloscope test

One instrument found in almost every service shop can be made to double as a gaussmeter—the oscilloscope. The basic principle of ion trap operation—deflection of an electron beam by a permanent magnet—is the secret of this makeshift gaussmeter. Instead of placing the trap around the neck of the scope tube, the electron beam is deflected at the *face* of the tube. The amount of deflection is a direct indication of ion trap magnet strength. Simple, isn't it?

net on the tube face, and strength of the ion trap magnet. Horizontal sweep frequency plays no part in the measurement. Positioning of the magnet on the tube face is not too critical and, with a little experience, accurate comparisons between magnets can be made. The photos show correct positioning of some types of traps. Other types should be positioned experimentally.

The best method of calibration is with ion trap magnets of known quality and of the same type as will be tested. An adjustable-strength single ion trap magnet will give an idea of loop height variation with magnet strength. The magnet used in Fig. 6 was adjustable from 32 to 55 gaussers. The loop height on my scope varied from ¼ to ½ inch.

A few minutes spent calibrating your oscilloscope, and a check of every ion trap magnet purchased, will insure that your next picture tube replacement won't find you with a dud magnet. END

from
KAY-TOWNES

comes
America's

**LEADING
ANTENNAS**

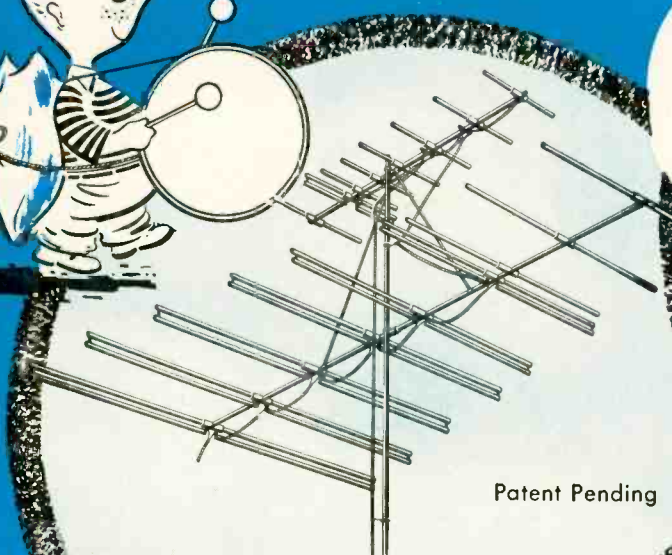

Patent Pending

SUPER GUARD
For Pin Point
Reception

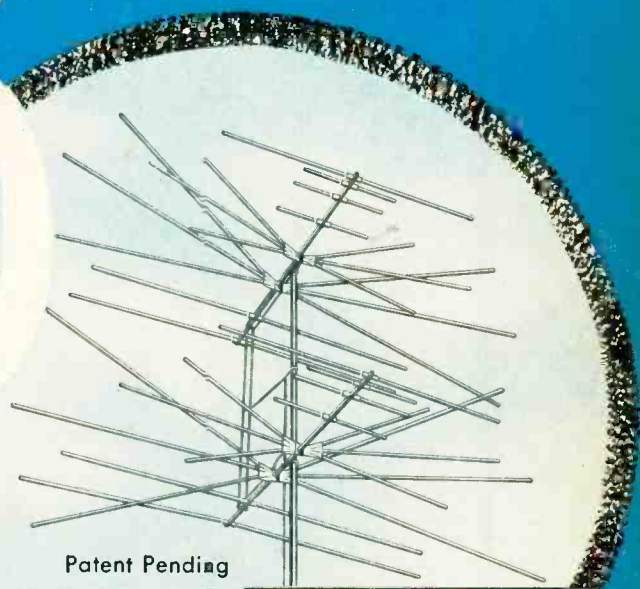

Patent Pending

SUPER KATY
A Proven
Performer

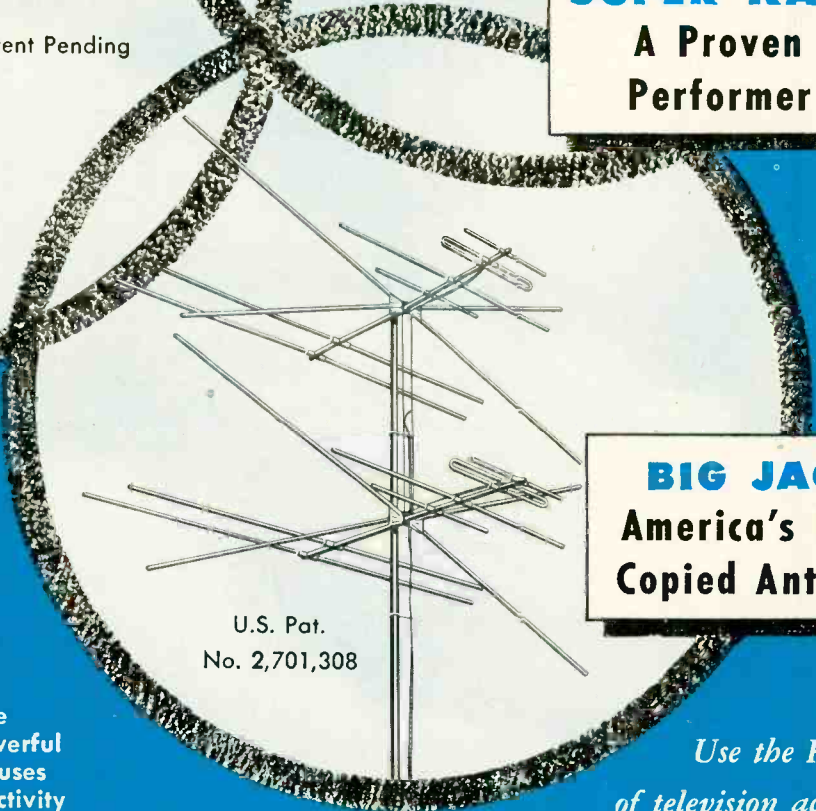

U.S. Pat.
No. 2,701,308

BIG JACK
America's Most
Copied Antenna

For the best in televiewing pleasure America's TV audience looks to Kay-Townes Antennas. The pace-setting **BIG JACK**, originated and patented by Kay-Townes, leads in sales across the nation. In fringe and problem areas the **SUPER KATY** has become a "proven performer" giving top-quality pictures where good reception had been next to impossible without it.

And now Kay-Townes is *first again* with the answer for TV fans living between two powerful stations. The Kay-Townes **REAR GUARD** refuses signals from the rear to give pin-point directivity and photo-clear reception in areas where reception has been practically impossible because of interference from near-by stations.

*Use the K-T line
of television accessories*

**QUICK RIG 'STANDOFF'
INSULATOR** for gutters, masts,
roof edges and window sills;
galvanized; available in
singles and doubles.



Manufactured and
Distributed in CANADA by
DELHI METAL PRODUCTS, LTD.,
DELHI, ONTARIO

THE FIRST NAME IN TV ANTENNAS

KAY-TOWNES
ANTENNA COMPANY
BOX 593A • ROME, GEORGIA

TV PICTURE SMEAR

By CYRUS GLICKSTEIN

TV picture smear can be produced by a large variety of troubles, originating in different sections of the receiver. To reduce troubleshooting time, the service technician should be familiar with its possible causes, methods of localizing, and specific remedies.

In smeared pictures, the outlines of large objects are blurred. Large black objects have a trailing white edge and large white areas a trailing black edge. The picture generally has a fuzzy appearance. However, picture smear should not be confused with poor focus, where both the picture and the raster lines on a blank channel are blurred. In a set with picture smear, the raster lines are well focused.

The most common cause of smear is insufficient or excessive low-frequency video response. Incorrect frequency response may originate in any of the three sections (Fig. 1) a video signal passes through before reaching the picture tube: the front end, video i.f. and video amplifier.

Possible causes of incorrect frequency response are: a faulty component (breakdown or change of value in any of the three sections); incorrect alignment (tuner and i.f. section) and incorrect component values in the original design of a new receiver model (usually in the video amplifier stages).

Other possible reasons for picture smear are signal overload at the antenna input, beat-frequency interference causing incorrect fine tuning and sweep circuit pickup in the video output. Smearing may also result from station transmission having a poor low-frequency response.

Each section the video signal passes through is designed to handle signals covering a specific frequency range. The front end must pass both the video r.f. and sound r.f. signals. The bandpass of the tuned circuits in the front end must have the general shape shown

in Fig. 2-a and be 6 mc wide. A too narrow r.f. response curve may, when optimum sound is tuned in, attenuate the incoming r.f. video signals. The resultant clipping of the vestigial sidebands reduces the low-frequency response of the receiver.

Incoming signals pass from the r.f. to the mixer stage, where they produce the video and sound i.f. The video i.f. signals (and in intercarrier sets, the sound i.f. signals) pass through the video i.f. section, consisting of three or four stages. The i.f. response curve, Fig. 2-b or 2-c, must pass the full range of video signals up to 4 mc from the video i.f. carrier. In addition, the i.f. response curve must compensate for the vestigial sideband transmission of video signals.

By rotating the fine tuning control past the optimum picture and sound point, the video i.f. carrier can be made to ride higher or lower on the slope. (Rotating the fine tuning control changes the oscillator frequency. This, in turn, changes the video and sound i.f. However, the i.f. bandpass remains fixed by the alignment of the i.f. section.) When the carrier is made to come in at a substantially higher point on the slope, the low-frequency response is increased. At the same time, the high-frequency response is reduced considerably, since the very high frequencies will no longer be within the i.f. bandpass. The result is a brighter, but blurred, smeary picture. The same condition can be caused by incorrect i.f. alignment or a defect in one of the i.f. stages.

When the fine tuning control is rotated in the opposite direction, the low-frequency response is attenuated since the carrier is lower on the slope. The high-frequency response may be increased somewhat. However, more sound i.f. signal passes through the video i.f. section, producing a grainy picture due to 4.5-mc beat interference. The low- and high-frequency response of the video i.f. section can thus be varied to some extent by rotating the fine tuning control past the normal tuning position. This point will come up again later in discussing quick checks for localizing trouble.

The video amplifier section, consisting of the detector and one or two video amplifier stages, should have a relatively flat bandpass (Fig. 2-d) from 60 to 4,000,000 cycles. Many faults (discussed later) can cause poor low-frequency response in this section.

Localizing defective section

When a picture is smeared and sound is normal, the following steps will help localize the defective section:

1. If video overload is suspected, remove one of the antenna lead-in wires. This will greatly reduce the signal input. If the defective picture was caused by overload, the picture will be weaker but less smeared. A more accurate check for overload is to connect an attenuator pad between the lead-in and antenna terminals and note the effect on the picture (Fig. 3). Commercial printed-circuit pads are available in 10-, 20-, 30- and 40-db attenuation values.

2. If the trouble is not caused by overload, note if the large areas become less smeared as the fine tuning control is rotated to one side of the best sound point. If so, the fault is most likely in the r.f. or i.f. section rather than the video amplifier. See also if 4.5-mc beat interference (fine diagonal) lines appear at the best sound point in split-sound receivers. If this happens, there is 4.5-mc interference in the video output. In such cases, the normal tendency is to leave the fine tuning control simply to reduce this interference. The fine tuning is left at a point where the video i.f. carrier is too high on the response curve and
(Continued on page 93)

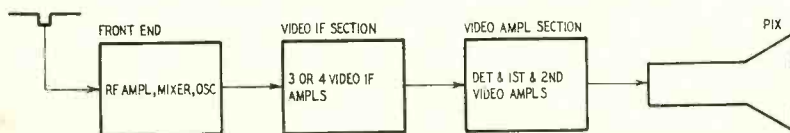

Fig. 1—Video signal path—each section contains a different frequency range.

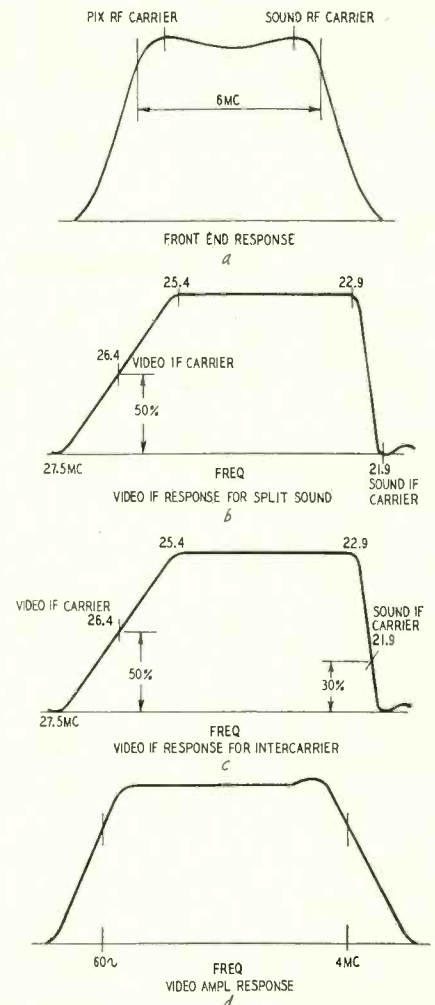

Fig. 2—Ideal TV response curves.

LAFAYETTE'S SPECTACULAR MONEY SAVERS



SALE!
26.50

Webcor
3 SPEED AUTOMATIC
RECORD CHANGER
Buy at Lafayette's
LOW SALE PRICE

- Brand new fully automatic 3 speed record changer
- Dual turn-over cartridge with dual styli
- Automatic shut-off after last record

You'll find this famous Webcor Diskchanger not only in Webcor Fonographs but in radio phonograph combinations of other famous manufacturers. This is truly supreme excellence in record changing. Not only does it play all 3 speeds and all sizes of records, but it plays up to four hours automatically... then shuts itself off after the last record has played. The Webcor Diskchanger was designed for swift, silent record changing; smooth, accurate turntable speeds; and gentle treatment of your precious records. To obtain these qualities, Webcor has included such outstanding features as the: Balanced Tone Arm, Electrostatically Flocked (super-soft) turntable, and a powerful 4 pole motor. Shpg. Wt. 16 lbs.

*PK-49... Singly, ea. **26.50**
WEBCOR WITH G. E. CARTRIDGE
STOCK NO. PK-46 Same as above but with G.E. RPX-050 Triple-play cartridge
List Price, \$51.75... **NET 29.50**

Lafayette
Greatest Tape Buy Ever!



1200 FT. REEL
Genuine Plastic Base
RECORDING TAPE
Shpg. Wt. 14 oz.

\$1.89 per roll plus postage

LAFAYETTE made a terrific deal with one of the leading manufacturers of recording tape to supply us with their regular tape which sells for almost twice our price. WE CANNOT OFFER ABSOLUTE SATISFACTION OR YOUR MONEY BACK. The finest, professional-quality recording tape obtainable. Highest performance for thousands of playings. Red Oxide base in a smooth, uniform coating; greater signal strength; with maximum fidelity; uniform frequency response from 40-15,000 cps.

In lots of 10 rolls - **1.75 ea**

LAFAYETTE EXCLUSIVE!
DYNAMIC EAR PHONE



A new lightweight plastic ear phone especially imported by Lafayette to bring you the high quality of a dynamic ear phone with the ease and comfort of an almost weightless unit—at a price less than half that of any comparable unit. Fits right into ear. Excellent sensitivity of 65 db. Ideal for use in miniature sets, hearing aids, transcribing, etc. DC resistance 2000 ohms, impedance 5000 ohms at 1000 cycles. Complete with 3 ft. plastic covered cord.

MS-72... **Net 1.95**

TV POWER TRANSFORMER

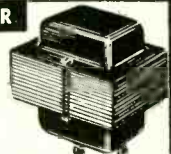

Exact replacement for Admiral 80C25-1. Plate volts 730V C.T. at 200 ma. and 215V at 65 ma. Rectifier 5V. at 3A. Filament—6.3V at 10A. and 6.3V at 2.5A. Useful general replacement.

TR-60—Lots of 3, each... **4.50**
Singly, each... **4.95**

FAMOUS ALARM-TIMER

- BUZZ ALARM SWITCH
- SLEEP SWITCH
- AUTOMATICALLY TURNS ON RADIOS, ETC.



We've done it again. We bought up the overstock of an equipment manufacturer to bring you this automatic 4-button timer at a giveaway price. Turns on radios, TV sets, toasters, etc. at any preset time within 12 hour period. Built-in SPST switch handles up to 15 amp 115 volts. Has sleep switch so you can go to sleep to music—it will automatically shut off radio at preset time up to 90 minutes. And it also tells time. Radium dial. For 110-120V 60 cycle. Shpg. Wt. 1 1/2 lbs.

MS-105... **Net 5.70**

5" Tweeter AND Crossover Network



7.95

A specially designed 5" Tweeter and Crossover Network that will assure high frequency response when used with any speaker you now possess. You can now make your present speaker into a 2-way speaker system increasing the high frequency range up to 15,000 cycles. Diagram included. Shpg. Wt. 5 lbs.

STOCK NO. SY-14... **Net 7.95**

BINOCULARS NEVER BEFORE AT THIS PRICE

IMPORTED DIRECT

- Prism-Coated Lenses
- All-Metal Construction
- Individual Focus
- Leather Case & Straps



F-105, 8 x 30 with case... **NET 18.25** with order.
F-15, 7 x 35 with case... **NET 19.95** Add 10%
F-103, 7 x 50 with case... **NET 21.95** Fed. Tax
F-104, 12 x 50 with case... **NET 32.50**

FREE RADIO CATALOG send for it
GET LAFAYETTE'S NEW CATALOG PACKED WITH THE LARGEST SELECTION OF QUALITY ELECTRONICS EQUIPMENT AT BARGAIN PRICES.

Lafayette Radio
NEW YORK, N.Y. 100 Sixth Ave.
BRONX, N.Y. 542 E. Fordham Rd
NEWARK, N.J. 24 Central Ave.
PLAINFIELD, N.J. 139 West 2nd St.
BOSTON, MASS. 110 Federal St.
include postage with order.

Masco

CASCADIAN TV BOOSTER

Reg. Price **\$42.50**

SALE 9.95



Biggest Booster Buy Ever!
Famous Masco Cascade Booster!!

- Three tuned circuits—cascode!
- Golden Grid 6BZ7 Plus 6J6 Plus rectifier!
- 35 db gain (56 times!) average on all channels!

A sensational new tunable VHF booster utilizing a special low-noise circuit. Employs the new Golden Grid 6BZ7 tube so well known for its use in cascode circuits. Field pioneer and specifically designed for new low noise-high gain front ends. Brings superior reception to older type receivers. Single knob control for utmost simplicity of operation. Signal strength is increased at least 56 times—35 db!—average on all channels. Rack and pinion permeability for precision stability. Automatically switched on and off by TV set. Uses cross-neutralized 6J6 and 6BZ7 tubes for maximum gain and bandwidth. U/L approved. For 110 volts AC. Wt. 5 lbs.

Masco TVB-53 in lots of 3, Net **9.45** Singly, ea. **9.95**

HI-FI PUSH PULL PHONO AMPLIFIER KIT

Hi-quality 4 tube push-pull phono amplifier kit. Plenty of power—low distortion. 2-35C5, 1-12AX7, 1-35W4. Inverse feedback circuit. Separate tone and volume controls. Complete with tubes—output transformer—pictorial and schematic diagrams.



KT-41
Net, each **9.95**

SALE
ASTATIC UHF CONVERTER
channels 14 thru 83
In Lots of 3... **13.95**
Singly, each... **14.45**

Below manufacturer's cost! Continuous vernier tuning—14 thru 83. Operates into TV receiver channels 2-3-4-5 and 6! Two-stage preselector. Fully shielded spiral inductance tuner reduces oscillator radiation. Uses 6AF4 or 6T4 and 1N82 crystal diode. High sensitivity—low noise performance!

ASTATIC UHF—Singly, each... **14.45**
In lots of 3, each... **13.95**

REAR SEAT AUTO SPEAKER KIT



A complete kit for adding another speaker in the rear of your car. You get a 6"x9" PM speaker with a 2.15 oz. Alnico V magnet; a CRL PK300 three position switch so you can select either speaker alone or both together, dial plate with mounting bracket, knob and hardware; a plastic grille (illustration A) (your choice of brown, grey or silver), wire and wiring instructions. Simple to install. Shpg. Wt. 4 lbs.

SK-36... **Net 4.50**

DELUXE 6" x 9" KIT

SK-37, with chrome plated metal grill (Fig. B). Shpg. Wt. 5 lbs. **Net 5.75**

MINIATURE CRYSTAL MICROPHONE

Here's a typical Lafayette special for the experimenter, student or dealer. An extremely sensitive and small crystal microphone used in hearing aids and other small apparatus. Can be used as lapel mike—miniature transmitter mike for concealed locations, etc. Its size and performance gives it joint versatility. Brand new. Size only 1 3/8" Diam x 5/16" deep. Imported to save you money.

MS-108... **Net 1.95**

DUAL STYLUS — TRIPLE PLAY DIAMOND and SAPPHIRE

11.95
Replacement for All G.E. RPX-050 Triple-Play Cartridges
Stock No. PK-29 **Net 11.95**

WESTERN ELECTRIC HEARING AID
Brand new, in original Western Electric's jeweler's case. Supplied with receiver, receiver cord, battery cover and plug (less batteries). Money back guarantee. Act now while they last. Uses Burgess XX30E PI and 8B batteries at \$1.68 per set.
Reg. Price **185.00**
Our Price **\$14.95**

UHF VHF FM
ALLIANCE TRI-CEPTOR ONE ANTENNA for ALL!

Sensational SMASHED
REGULAR PRICE **\$47.50**
A new revolutionary design with monolobe, highly directional pattern that covers all channels 2-83. Features great power, minimizing or eliminating interference and ghosts. High front-to-back ratio: UHF and VHF lobe patterns in line, off front of antenna. Tubular built seamed aluminum elements, seamless boom, fibre glass and low dielectric loss insulation, zero loss impedance matching transformer between antennas. All hardware mounted. TC-2—Double bay—Shpg. Wt. 12 1/2 lbs.
11.95
12.45 singly.
Rotor and Mast not included.
Net—Lots of 3, ea. **11.95** Singly, each... **12.45**

SALE! RADIO RECEPTOR UHF CAVITUNER

Complete with 6 AF4, 6BZ7 and 1N82
Tunes all UHF channels 14-82. Most advanced engineering, three cavities, two used as bandpass pre-selector, one controlling local oscillator. Features frequency stability, uniformly broad bandwidth, high selectivity, low noise, high gain. Completely shielded. Ideal for building converters, etc. Size 3 1/4" H x 4 3/4" W x 4 3/4" D. Shpg. Wt. 4 1/2 lbs.
TL-26... Lots of 3, ea. **4.45**
Singly, ea. **4.95**

craftsmen GOES DIRECT!

Bringing these Savings to You . . .

Effective March 1, Radio Craftsmen will begin a new policy—
"Selling directly to you."

The same fine Craftsmen Components that have previously been sold only through High Fidelity Dealers and Radio Parts Distributors can now be purchased direct from the factory—at tremendous savings. This new sales policy is designed to offer you the finest High Fidelity Equipment at the lowest possible price.



CRAFTSMEN *Solitaire*

Here is the finest, most flexible unit offered by any manufacturer. All you need for a professional home music system is the Solitaire, a fine record player and speaker. This exceptional new unit contains a full 20 watt power amplifier, a preamplifier and an exclusive sharp cut-off filter, housed in an attractive cabinet of leather etched steel. Inputs for magnetic phono cartridge, FM-AM tuner, tape recorder and TV receiver. Six record equalization positions. Contour type loudness control, and separate bass and treble tone controls giving 15 db boost and 13 db attenuation. Sharp cut-off filter system removes both high and low frequency noises. Basic amplifier is based on Williamson Ultra-linear design. Frequency response: ± 0.5 db, 20-20,000 cycles. IM distortion less than 2% at 20 watts. Size: 4 x 14½ x 11½", Weight 25 lbs.
Price was \$113.50 **NOW ONLY \$86.50**

C10 FM-AM Tuner

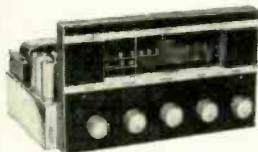

There are more C10 tuners now in use than any other FM-AM tuners ever made. The proof of its exceptional performance and durability is in the thousands of installations in homes, leading radio and TV stations, schools and hospitals. Has independent, continuously variable tone controls, built-in preamplifier, and two cathode follower outputs. Frequency Response: 20 to 20,000 cps. Sensitivity less than 5 microvolts. AFC for simplified, "no-drift" tuning. 12 tubes including rectifier. Weight—17 lbs.
Was \$131.50 **NOW ONLY \$107.50**

C1000 FM-AM Tuner

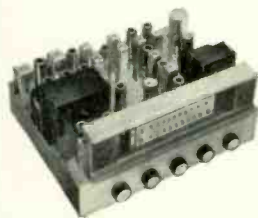

For more than just a tuner, the C1000 is a complete control center for your Hi-Fi system. Here is a superior FM-AM tuner, a complete preamplifier with 4 positions of record equalization and input circuits for TV, tape recorder and phono. Has two AM bandwidths; broad for local Hi-Fi and sharp for distant or noisy stations. FM sensitivity; 2 mv for 30 db quieting. AFC and 2 cathode follower outputs. Wt. 25 lbs.
Was \$179.50 **NOW ONLY \$161.00**

C900 Basic FM Tuner



For use with Solitaire or C350 Preamplifier. Designed for broadcast monitoring where low distortion, ultimate stability, and high sensitivity are needed. Exclusive printed IF coils (20.6 mc); variable amplified AFC and lower over-all distortion than any station. Frequency response $\pm 1/2$ db 20-20,000 cycles. Overall IM distortion for 100% modulation less than .05%. Sensitivity, 2 microvolts for 30 db quieting. Weight 17 lbs.
Was \$119.50 **NOW ONLY \$99.50**

C810 Basic FM-AM Tuner



For use with the Solitaire or C350 preamplifier. Does not have built in preamplifier or tone controls. Exceptional FM sensitivity (4 mv. for 30 db of quieting) and wide band AM for true high fidelity performance. Frequency response ± 1 db 20-20,000 cps. Weight 21 lbs.
Price was \$134.50 **NOW ONLY \$97.50**

C550 30 Watt Amplifier

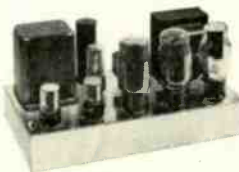

Here is maximum ruggedness, dependability and flawless reproduction at any volume level. Thirty full watts of audio power with only 0.1% harmonic and 0.5% IM distortion. Frequency response is far beyond the audible range (± 1 db 10-100,000 cps.) Special thermal time delay protects circuit. KT66 output tubes used exclusively for maximum efficiency. Wt. 33 lbs.
Was \$109.50 **NOW ONLY \$89.50**

C400 Audio Amplifier



Exceptional performance at low cost. Streamlined narrow chassis for ease of installation. Push-pull 6V6 beam-tetrode tubes plus 13.5 db negative feedback provide 10 watts output with frequency response of 15 to 20,000 cps. (± 1 db). Harmonic distortion less than 1%, hum and noise level 70 db below rated output. Five tubes including rectifier. Weight 13 lbs.
Was \$42.90 **NOW ONLY \$29.50**

C450 Audio Amplifier

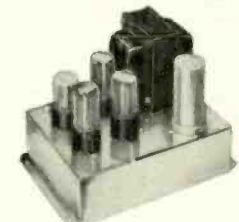

Ideal for budget Hi-Fi systems. Has same high quality craftsmanship as other Craftsmen amplifiers but with lower output of 6 watts. Frequency response: 20 to 20,000 cps. (± 1 db) with only one percent harmonic distortion. Push-pull 6W6GT beam-tetrode output tubes. Only 6 x 8½ x 6 inches. Weight 10 lbs.
Was \$29.50 **NOW ONLY \$19.50**

Order direct from factory and save. Only by selling direct can Craftsmen offer you these exceptional units at so low a price. Don't delay—Order by Mail Today.

The Radio Craftsmen Inc, Dept. G4, 4403 N. Ravenswood Ave. Chicago 40, Illinois

Southern California: Henry Radio, 11240 West Olympic Blvd., Los Angeles, Calif.

World's Largest Exclusive Makers of High Fidelity Equipment

TELEVISION

the sound i.f. carrier (and some of the higher video frequencies) is outside the bandpass. Picture smear, of course, results. Where this occurs, the fault basically is not picture smear but 4.5-mc beat interference. To eliminate the smear, it is necessary to eliminate the interference.

3. If the fine tuning control has to be turned further to bring in a better picture on one or more channels, but reaches the limit of rotation, the r.f. oscillator frequency of that channel must be realigned.

4. Turn the channel selector switch through the range of active channels. If smear is present on only one channel, the fault—if not caused by defective station transmission, overload or incorrect r.f. oscillator frequency in the receiver—is in the r.f. alignment of that channel rather than in the video i.f. or amplifier sections.

5. If smear is noted on all channels and is not improved by a small rotation of the fine tuning control, the fault is most likely in the video amplifier section.

In some cases, the results of these quick checks may be inconclusive. If the receiver is on the bench, an alignment check can be made. The standard method for checking the r.f. or i.f. bandpass is with sweep and marker generators and an oscilloscope, using the same hookup as for alignment. However, a simple check of r.f. or i.f. bandpass can be made with an AM generator and a v.t.v.m.

A frequency response check of the video amplifier section is a more difficult project from the standpoint of equipment needed. The quickest method is to apply a square-wave signal at the video detector load and use a wide-band oscilloscope at the output of the last video amplifier stage. The output waveform is then checked for distortion.

If the r.f. or i.f. bandpass checks indicate a poor response curve, this does not mean realignment is necessary. A defective part may be responsible for the trouble. If there is some doubt about the defective section, change the tubes in all three video sections. If the trouble is not a defective tube, the i.f. and tuner tubes should be replaced in their original position to minimize any change in r.f. and i.f. alignment.

Other possible troubles and cures in each of the three video sections are:

R.f. section

1. Excessive input at the antenna terminals can cause picture jitter as

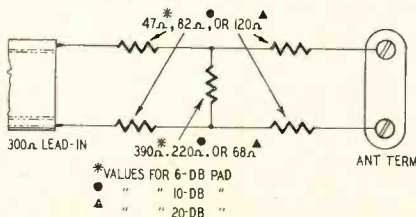

Fig. 3—Signal attenuator network.

BUY DIRECT and SAVE!

Order by mail direct from factory, the finest equipment in high fidelity.

The best known name in high fidelity

craftsmen

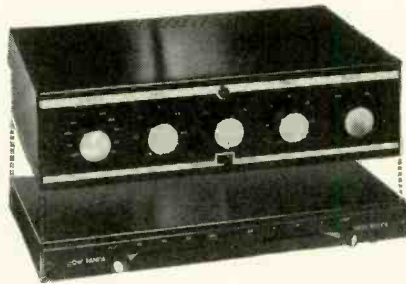

C350 Equalizer Preamplifier

New audio control system designed for exceptional flexibility and low distortion. Has exclusive "Hinged tone control circuit"—eliminates honk and rasp typical of conventional tone controls. Seven accurate record equalization positions. New British Z729 preamplifier tube results in a new low in noise, hum and distortion. New compensated Loudness Control reinforces highs and lows at soft volume settings. Has 4 input circuits for FM-AM tuner, TV, tape recorder and magnetic cartridge. Two cathode follower outputs for amplifier and recording systems. All-triode circuitry reduces distortion to vanishing point. Wt. 11 lbs. Was \$129.50 NOW ONLY \$89.50

C375 Sharp Cut-Off Filter System

Eliminates distortion present at the extremes of frequency range. Invaluable in obtaining maximum enjoyment from records, tape or FM broadcasts. Low frequency cut-off points: Flat, 40, 70, 120 and 200 cycles, reducing hum or turntable rumble. High frequency cut-off points: Flat, 9KC, 6KC, 4KC and 2.8KC. In flat position frequency response is ± 0.5 db, 20-20,000 cycles. Weight 8 lbs. Was \$39.50 NOW ONLY \$33.50

15 Day Trial Guarantee

You must be fully satisfied during 15 day trial period. If not, return equipment for full refund of purchase price.

Save by mail. Order today direct from Craftsmen.

Now you can have the finest High Fidelity equipment made . . . at the lowest prices ever offered.

All equipment fully guaranteed and covered by Craftsmen Factory Warranty.

THE RADIO craftsmen INC.

Dept. G4, 4403 Ravenswood Avenue, Chicago 40, Illinois

Order Blank

UPTown 8-4000

Send me complete Craftsmen Catalog SHIP VIA
 Name _____ Express
 Address _____ Freight
 Best Way

Quantity	Model No.	Item	Price

Check or M.O. enclosed
 Send COD. (25% prepayment enclosed)
 Orders from Canada and APO's must include full remittance.

On Express orders do not include transportation charges—they will be collected by the express agency at time of delivery.
 All Orders F.O.B. Chicago

World's Largest Exclusive Makers of High Fidelity Equipment

Engineering

WRITERS

ENGINEERS, E. E. or PHYSICS GRADUATES, for preparation of technical manuals...

HUGHES RESEARCH AND DEVELOPMENT LABORATORIES' expanding program for production of radar, electronic digital computers, guided missiles and other military advanced electronic systems and devices requires the following:

1 ELECTRICAL ENGINEERING AND PHYSICS GRADUATES to prepare operating, servicing and overhauling instructions for complex electronic equipment. Those with previous maintenance experience on military equipment preferred. Writers will participate in a three-month program in our technical training school to become familiar with the latest Hughes equipment prior to writing assignments.

2 ENGINEERS EXPERIENCED in the writing and preparation of maintenance manuals for electronic equipment or guided missiles. These specialists will work step-by-step with the people designing, developing and manufacturing the products involved. Experience in the writing of engineering reports is of value.

HOW TO APPLY

Write full details of your qualifications to

HUGHES

Research and Development Laboratories

SCIENTIFIC AND ENGINEERING STAFF
Culver City, Los Angeles County
California

Assurance is required that relocation of the applicant will not cause disruption of an urgent military project.

TELEVISION

well as smear. Overload is not controllable by varying the contrast control, since it occurs in the r.f. stage. To remedy overload, first check the adjustment of the a.g.c. control, if the receiver has one. Where this adjustment does not remedy the condition or no control is provided, an attenuation network should be connected at the antenna terminals. The values for several attenuator networks are shown in Fig. 4. The amount of attenuation needed is determined by the amount of overload. Carbon resistors only should be used.

2. Where a channel is affected because the fine tuning control must be turned to the limit of rotation without tuning in a clear picture, turn the fine tuning to the center of rotation and adjust the oscillator slug.

3. A complete r.f. or i.f. realignment should be undertaken only when the need has been definitely established—that is, when there is no defective part and the bandpass curve is completely off. If only a small portion of the bandpass curve is beyond the acceptable tolerance, as determined by an v.t.v.m. or sweep generator check, a complete realignment is usually not necessary. Note which part of the bandpass curve is off the most. Check the schematic and the manufacturer's alignment instructions to determine which adjustment has the most effect at that frequency. Then make the adjustment slowly while watching the picture. In any touchup procedure, it is always a good policy to note the starting position of the slug slot and to count the number of times the slug is turned. In this way, it is always possible to return to the starting position if rotation of the slug in either direction does not remedy the fault.

Where a complete realignment is required, an accurate AM generator can be used to peak adjustments at the correct frequency in stagger-tuned i.f. stages, but overall alignment should be checked by a sweep generator and accurate marker frequencies. The manufacturer's specifications should be carefully followed when a complete realignment is made. These specifications usually include techniques that vary slightly with the various models.

i.f. section

1. Open screen, cathode bypass or decoupling capacitors or defective plate, screen or cathode resistors can reduce the gain of an i.f. stage. This affects the i.f. response curve most at the fre-

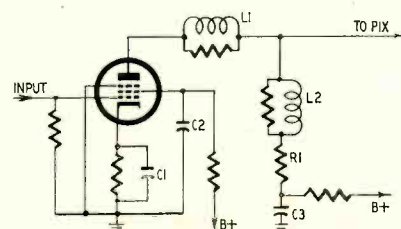

Fig. 4—Typical video amplifier stage.

quency to which the particular stage is tuned. When a check of the i.f. bandpass shows a fault in a given part of the curve, check those stages responsible for that portion of the response curve. Check also for a defective coil in the stage's tuned circuit.

2. Where aging of components results in a need for realignment, check whether a complete realignment is necessary.

Video amplifier section

The following faults in this section can cause picture smear:

1. Incorrect values of coupling capacitors. A direct-coupled video amplifier does not necessarily guarantee good low-frequency response.

2. Incorrect values of cathode bypass (C1) and screen bypass (C2) capacitors in the video amplifier (Fig. 4) stages. An open decoupling capacitor (C3) increases the effective value of the plate load resistor.

3. A defective load resistor (R1) in the video amplifier or video detector stage can cause poor definition, smearing, poor contrast or poor sync stability. When load resistors in this section increase in value, the stray capacitance in the load circuit shunts a larger proportion of the higher video frequencies around the resistors. In effect, the high-frequency response of the circuit is reduced greatly while the low-frequency response is boosted. The picture accordingly loses detail and may become smeared.

4. A 4.5-mc beat in the picture can be minimized by detuning the fine tuning control. If the set has one, retune the 4.5-mc trap for minimum interference. In some cases, it may be necessary to install a 4.5-mc trap between the plate of the output video amplifier and the C-R tube.

5. Open peaking coils (L1 and L2 in Fig. 4).

6. Defective video detector crystal.

7. If the hot horizontal deflection yoke lead is dressed too close to the picture-tube video (cathode or grid) lead, horizontal voltage pulses can be coupled to the picture-tube input. This may cause the picture tube to draw grid current. To avoid this, dress the two leads away from each other but not near the vertical deflection leads.

Where the low-frequency response of a new receiver is below par, it is usually helpful to check the field service bulletins of the manufacturer. Typical suggestions for improvement include:

1. Add a 1,500- to 4,700- μf capacitor across the previously unbypassed cathode resistor of the video amplifier.

2. Change the peaking coil in the grid circuit of the first video amplifier from 120 to 500 μh .

3. Dress coupling capacitor leads in the video amplifier section away from each other.

4. Increase the value of coupling capacitance between stages in the video amplifier section up to a maximum of 0.22 μf to increase the low-frequency response.

END

WIN-TRONIX

LOW COST
TV TEST
INSTRUMENTS

NEW

Buy Now for BL. & WH. Service
—and be ready for COLOR

COMPATIBLE FOR

COLOR

and

BLACK AND WHITE

CHECK THESE FEATURES!

- ✓ COMPATIBLE ADVANCED DESIGN PREVENTS OBSOLESCENCE.
- ✓ LOW COST WITH HIGH QUALITY.
- ✓ PORTABILITY.
- ✓ STANDARD WARRANTY ON ALL INSTRUMENTS.

SEE YOUR PARTS JOBBER! WRITE TODAY FOR LITERATURE!



WHITE-DOT and LINEARITY GENERATOR

- ▶ **COLOR CONVERGENCE** — A must on every color service call — gives large and small white dots.
- ▶ **BLACK & WHITE** — Linearity & picture size adjustments.

Model 160 **\$7995**



RAINBOW GENERATOR

This Color Pattern Generator produces New Linear Phase Sweep for faster color TV servicing.

- ▶ **APPLICATIONS:**
 - All chroma circuit tests.
 - Color demod. phase alignment.
 - Color gain adjustments.
 - Matrix test and alignment.
 - 3.58 mc traps and coils.

Model 150 **\$4995**
PATENT PENDING

SWEEP CIRCUIT ANALYZER

NEW! The complete sweep circuit tester — takes the guesswork out of sweep circuit troubleshooting.

- ▶ **TWO INSTRUMENTS IN ONE**
 1. Horizontal and vertical sawtooth for signal substitution. (15KC and 60 CPS.)
 2. Complete flyback and yoke testers.



Model 820 **\$5995**

FOR COLOR OR BLACK & WHITE

FLYBACK and YOKE TESTER

NEW! Sensitive circuit checks one turn shorts in yokes as well as xfms.

- ▶ Oscillating neon indicator more sensitive than a meter.
- ▶ Advanced design also tests color yokes and xfms.
- ▶ Saves time with fast test of —
 - Flyback transformers
 - Deflection yokes
 - Bypass and electrolytic condensers
 - Continuity of coils, xfms



Model 810 **\$2995**

FOR COLOR OR BLACK & WHITE

COMPATIBLE FIELD STRENGTH METER

VHF and UHF

NEW! Here is the FSM that won't be made obsolete by color TV!

For good antenna installations (color or bl. & wh.) **YOU NEED:**

1. Microvolt testing
2. Bandwidth testing

FEATURES:

- ▶ Tests for color performance on antenna installations.
- ▶ Tests for bandwidth for better bl. & wh. pictures.
- ▶ Reads microvolts directly on 5 scales.
- ▶ Channels 2-13; extra coils available for UHF channels.



Model 330 **\$12995**

FOR COLOR OR BLACK & WHITE

COMPATIBLE CRYSTAL CALIBRATOR

NEW! Crystal controlled generator and crystal tester

FOR:

- ▶ Color and bl. & wh. servicing
- ▶ Labs and factories
- ▶ Amateurs and experimenters

FEATURES:

- ▶ Accurate 3.579545MC color sub-carrier standard, factory calibrated (crystal supplied).
- ▶ Three external crystals* and a crystal switch permit quick selection of precise frequencies.

APPLICATIONS:

- 3.579545MC color oscillator alignment.
- Crystal tester.
- RF and IF marker and calibrator.*
- Color TV 3.58MC generator.
- Microsecond time marker for scopes.*



Model 120 **\$5995**

FOR COLOR OR BLACK & WHITE

*These crystals available extra

WINSTON ELECTRONICS, INC.

RE-455 4312 Main St., Philadelphia 27, Pa.

TRANSISTOR RADIO

uses NO POWER SUPPLY

Here's what many have looked for—something for nothing
By WILLIAM H. GRACE, JR.

RECENT statistics on the sales of crystal receivers plus the sales of radio parts for such sets to hobbyists indicate that there may be approximately a quarter of a million such receivers in use throughout the world. One manufacturer reports sales of 50,000 crystal sets during 1954. The reasons are cheap and dependable reception, good fidelity, low initial cost and next to no upkeep expense. The main disadvantage of crystal receivers is the low sound volume in the headphones or speaker. This deficit could be remedied by a stage of tube or transistor audio amplification but this requires some external source of power.

The circuit described in this article provides a stage of transistor audio amplification of moderate gain without requiring any external power source of a conventional type whatever. I originated the circuit several years ago while experimenting with standard audio circuits and it has proven itself practical and effective.

This circuit comes as close to giving something for nothing as you are apt to see in a long time. Because of this characteristic, it seemed to be just naturally wedded to a crystal receiver.

If you live in a location where a crystal receiver will provide a good signal, this battery-less transistor amplifier will almost double the volume. The crystal tuner (see diagram) is the conventional tuned-primary-tuned-secondary affair used for years by crystal experimenters and before that by ship-to-shore stations in the days of spark transmitters. A 1N34 germanium diode is used as a detector-rectifier. Any suitable type of diode may be substituted in place of the 1N34, and one of the newer gold-bonded silicon types having lower front and

higher back impedances might well prove superior to the germanium ones.

The audio stage requires but two additional parts, a Raytheon CK722 or similar junction transistor, and a fixed capacitor whose actual value appears not too critical. Almost any value be-

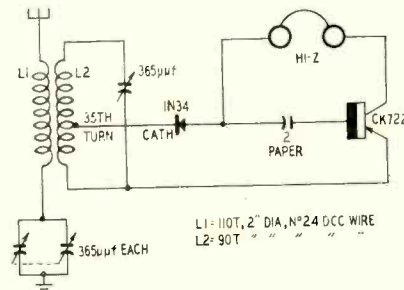

Schematic of the battery-less amplifier.

tween .05 and 5 μf will suffice. I used a miniature 2- μf paper capacitor because it was at hand and functioned satisfactorily. The operation of the amplifier is extremely simple. It depends upon the fact that the output of the diode consists of two separate components—the modulated signal current and the rectified carrier d.c. This d.c., useless in the ordinary crystal receiver, is applied to the collector of the transistor and powers the audio stage. In other words, the rectified carrier current is put to work in the collector circuit to increase the signal current from the diode.

If your crystal set has an output of around 100 microamperes (measured across the phone jacks), worth-while amplification will be obtained from this system. If an output of 500 or more microamperes can be obtained, considerably greater volume will result. The louder the signal to begin with, the

greater will be the usable d.c. from the carrier and the greater the gain.

The polarity of the diode is most important. If it is reversed, there will be no amplification. The polarity shown in the diagram is correct for use with the CK722 or other transistors of the p-n-p type. These transistors require a negative collector. If a transistor of the n-p-n type is used, the diode will have to be reversed because, in this case, the collector will have to be biased positively.

The amount of amplification or gain from an amplifier of this type is not equal to that of one using an external source of d.c. power plus proper emitter bias, but sufficient gain is obtained on strong local signals to produce very high headphone volume. In strong field-strength areas moderate speaker volume can be realized with only the single stage of audio. Various modifications of the circuit, such as using transformer-coupled arrangements, proved successful. I found it practical to take the rectified carrier d.c. from a frequency other than the one that furnishes the signal current. Test various types of transistors in this basic circuit; the resulting gain depends to a considerable extent upon the characteristics of the particular transistor used. However, the CK722 type will function well and is among the least expensive of the models now available to the builder. This "something-for-nothing" circuit is almost foolproof. END

Parts for battery-less amplifier

1—high-impedance headphones; 1—CK722 transistor; 1—1N34 crystal; 1—2- μf capacitor (see text); 1—365- μf tuning capacitor; 1—2-gang tuning capacitor, 365 μf each; 1—primary coil (L1), 110 turns, 2-inch diameter, No. 24 d.c.c. wire; 1—secondary coil (L2), 90 turns, 2-inch diameter, No. 24 d.c.c. wire, tapped at 35th turn from the low end.

Sylvania "600 ma" Tubes

99.7 proof*

FOR SERIES-STRING TV

RADIO ELECTRONICS



* In a 15-tube series string, analysis proved that 99.7% of all probable combinations of Sylvania types operated within 2% of the heater-current design center. Sylvania's tight heater-current limit is one of the most important contributions to tube performance for series string operation.

Best for Service In 4 big ways

WHEN YOU SERVICE TV SETS using series-string-heater tubes, don't take chances on call backs. Here are four big reasons why only Sylvania "600 ma" tubes give you the uniform, dependable performance that insures customer satisfaction.

1. Less heater voltage variations—even distribution of tube voltages

throughout the series string insures better tube life.

2. Less heater burn-outs—heater burn-outs are reduced because the controlled heater warm-up of 11 seconds is uniform from tube to tube throughout the circuit.

3. Less time for normal set operation—controlled heater warm-up brings set to normal operation in less than half the time.

4. More uniformity—because Sylvania makes everything but the bulb, quality is controlled from raw materials straight through to finished product.

Write for this handy reference guide to Sylvania tubes for series string television. It's both a brochure and wall chart! Write Department D35N.

All Sylvania TV PICTURE TUBES now have heaters specially controlled for series string operation!



SYLVANIA

Sylvania Electric Products Inc.
1740 Broadway, New York 19, N. Y.
In Canada: Sylvania Electric (Canada) Ltd.
University Tower Bldg., St. Catherine St.
Montreal, P. Q.

LIGHTING • RADIO • ELECTRONICS • TELEVISION • ATOMIC ENERGY

EMERGENCY RECEIVER By T. W. DRESSER

SOME time ago—September, 1951—in an editorial, Hugo Gernsback called attention to the need for a portable radio, light in weight, capable of being carried in the pocket, yet robust enough for use in emergencies such as heavy bombing raids. Here in Britain we suffered such need in the last war. In the writer's home town 87,000 houses out of a prewar total of 92,000 were damaged or destroyed and the death toll ran into four figures. We know the wisdom of his words. Living under the constant threat of invasion and with our electricity frequently cut off for long periods it was essential that a reliable means be found to insure reception of the news. That could mean only one thing—battery radio. As most nights were spent in air-raid shelters, the radio had to be small and portable.

The primary aim in designing such a radio is to make sure of good signals from at least Home stations. As broadcast stations are no less vulnerable to bombing than homes or factories, it is not considered advisable to rely solely upon the local station or upon one band. Because it was known that no British short-wave station suffered damage from bombing—probably due to their isolated locations—our home-constructed miniature portables were generally designed to cover short waves only, or a section of the broadcast band plus short waves from 12 to 70 meters.

The first receiver we built was a single-tube effort—for short waves only—using a standard arrangement (Fig. 1) of regenerative detector and audio amplifier. A 3A5 fulfilled both purposes, transformer coupling being used between the two sections to increase gain. The output can be taken to a 2-inch speaker, but a single earphone was used in preference, being lighter in weight and eliminating the need for an output transformer. The unit was built into a case made of 16-gauge aluminum, measuring 6 x 4 x 1.5

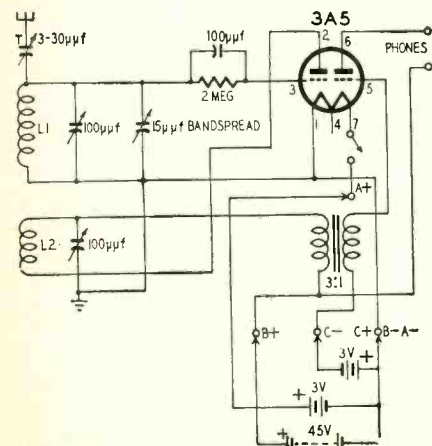
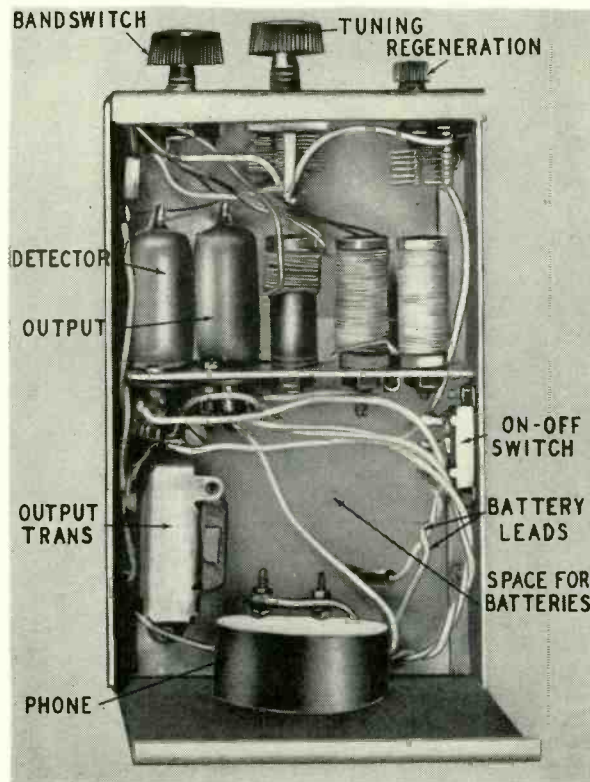

Fig. 1—Emergency portable receiver.



A view of the 6½ x 3½ x 1½-inch chassis with the cover removed to show the insides. A single phone is in the cover. Set is held to the ear when in operation.

inches. It was powered by a 3-volt A battery, 3-volt bias battery, and two 22.5-volt B batteries in series, all being featherweight or hearing-aid types. Miniature type parts were used throughout, including the earphone, and the coils were plug-ins (Table 1).

This receiver tuned from 15 to 42 meters and 38 to 75 meters in two bands. With a 30-foot length of thin, rubber-covered, flexible wire as antenna, it gave excellent results on Home stations and good results on signals from the United States, Canada, Belgian Congo, and as far away as the Dutch East Indies.

Arising from the experience with this receiver, a more ambitious project was started early in 1942. By this time the majority of such radios had resolved themselves into some variation of the Hartley circuit. The reason for this choice was fairly obvious. The arrangement was probably the most efficient there is, for simple t.r.f. circuits of this kind. It provides excellent performance on both short-wave and broadcast bands, whereas the mag-

netic feedback circuit of Fig. 1, while O.K. on broadcast bands, has a tendency to make the tuning rather critical on short-wave. The Colpitts circuit has a big drawback in its use of series tuning capacitors, although in all other respects it is quite good. The only objection to the Hartley is that both sides of the tuning capacitor are hot to r.f., consequently, hand capacitance would affect tuning badly unless precautions are taken. This can be done by using an insulated shaft and a coupler between the control knob and the capacitor shaft proper.

The receiver, built on these lines and still in use today, weighs 17 ounces and can be carried in most coat pockets. The schematic is shown in Fig. 2 and incorporates many of the ideas used in the previous model. Transformer coupling is again used and a single earphone replaces a

TABLE 1—Specifications for Fig. 1 Coils

Band	L1	L2
15-40 Meters	13 T spaced to 1¼ inches.	4 T close-wound, ½ inch from ground end of grid coil.
40-75 Meters	23 T spaced to 1⅝ inches.	6 T close-wound, ⅛ inch from ground end of grid coil.

Both coil forms 1-inch diameter, and all windings with No. 24 wire.

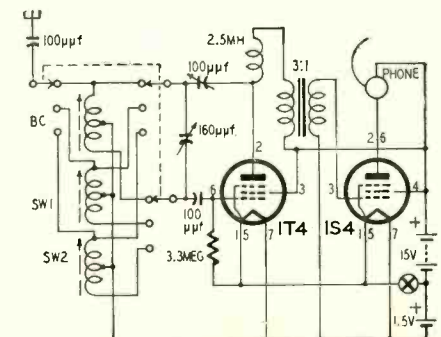

Fig. 2—Improved emergency portable.



G-C LUMINOUS LITE-KOAT KIT
Coat dials, switches, etc., with this long-life, non-poisonous "glow in the dark" coating.
No. 184-0 NET \$1.95



G-C PICTURE TUBE EXTENSION
Extends picture tube leads from chassis to tube when servicing set. Complete, 48 inches.
No. 8856 NET \$1.50



G-C ELEC., RESISTOR CEMENT
Ideal for resistors, appliances, etc. Heat-proof, hardens like porcelain.
No. 27-2 2-oz. bottle NET \$0.39



G-C SILVER PRINT
Pure silver compound used to repair printed circuits. Handy for touch-up, labs, etc.
No. 21-2 Troy oz. NET \$4.65



G-C DE-OX-ID KIT
Handy contact cleaner for switches, controls, relays. Kit contains 2 oz. De-Ox-Id and needle-type injector.
No. 8460 NET \$0.99



G-C TV PORTO MIRROR
Heavy chrome plated mirror for adjusting TV sets. Rubber lined spring clamp.
No. 8198 NET \$2.58



G-C STRIP-X
Removes insulating enamel from wires for easy soldering. Simply dip and wipe!
No. 26-2 2 oz. bottle NET \$0.39



G-C CREME-O-WAX POLISH
White, non-staining polish for furniture, TV and radio cabinets. Dries to hard gloss.
No. 95-16 16-oz. bottle NET \$0.66



G-C CABINET REPAIR KIT
Contains 10 shades of shellac sticks, stains, varnish, brushes, everything for cabinet repairs. Easy to use.
No. 901 NET \$4.50

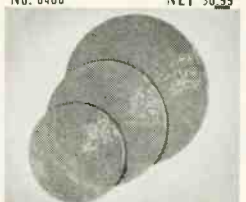

G-C RECORD TURNTABLE FELT
Ready-cut replacements, center hole.
No. 1292 7 7/8" dia. NET \$0.30
No. 1293 9 7/8" dia. .42
No. 1294 11 7/8" dia. .51



G-C PLASTIC STOCK BOX
Handy, covered polystyrene box for stocking screws, nuts, resistors, capacitors, etc. 4x4x2 1/2".
No. 8022 NET \$0.36



G-C 1/2" JEWEL SIGNAL LIGHT
Miniature screw base jewel in red, green, blue, amber, opal, clear (specify). 7/16" mtg. hole.
No. 7910 NET \$0.27

GENERAL



CEMENT

Ask For These
RADIO-TV SERVICE AIDS

... at Your Jobber



G-C FUSE CONNECTOR
Regular type used on car radios, etc. 2 1/2" long x 3/8" dia. For 1/4" fuses.
No. 1749 NET \$0.15

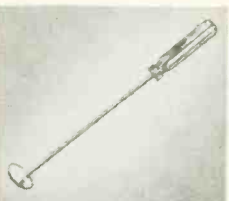

G-C INSPECTION MIRROR
Get into those hard-to-reach corners. inspect coils, connections, etc.
No. 5090 NET \$0.33

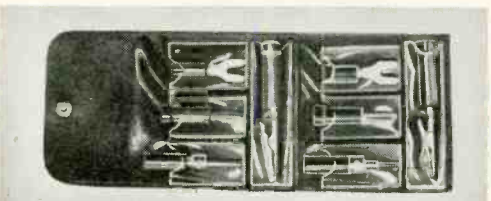

G-C TEST LEAD PLUG INTERCHANGE KIT
Easy to switch alligator clips, banana plugs, spade lugs, phone tips. Fitted plastic case holds one each in red and black.
No. 7743 NET \$1.95



G-C ELECTRONIC HARDWARE LAB
Contains 60 most popular items in G-C 50 Line, each in hinged cover box. Good looking steel rack (9" x 13 1/2" x 2 1/2") for bench or wall mounting included in kit without charge.
No. 3660 NET \$19.50



G-C SWEDISH STEEL SHIMS
Leatherette kit includes 16 high grade shims for speaker repair. Sizes: .004", .006", .008", .010".
No. 701 NET \$0.54

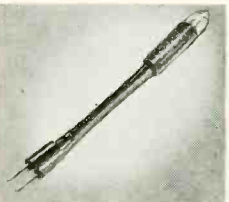

G-C NE-O-LITE TESTER
Neon glow lamp circuit tester for many uses. 60 V. AC to 550 V. AC-DC.
No. 5100 NET \$0.36



G-C ALLEN-BRISTO WRENCH KIT
Complete kit for both hex and spline type screws. Leatherette case, 12 wrenches.
No. 5028 NET \$1.08

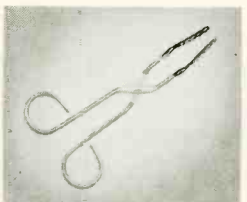

G-C TUBE & PARTS EXTRACTOR
Originally designed for Signal Corps. Spring steel, cadmium plated. Prongs rubber cushioned.
No. 5092 NET \$0.99



G-C MINIATURE TUBE PULLER
Suction, vacuum principle tool prevents tube breakage, burned fingers. Easy to use, saves time.
No. 5093 for 7-pin tubes NET \$1.08
No. 8106 for 9-pin tubes 1.08



G-C UHF HOLLOW LINE CAPS
Seals round and oval hollow line ends. Easy to slip cap over end of line, eliminates heat sealing.
No. H8912 Box of 8 NET \$0.30



G-C BO ELIMINATOR
Eliminates Barkhausen Oscillation in horizontal sweep output tubes. Easy to install and adjust.
No. 8749 NET \$0.75



G-C BEAM-O-CENTER
Beam adjuster fits in back of tube yoke coil to center picture. Bakelite housing. Easy adjusting.
No. 8956 NET \$1.05



G-C TV HIGH VOLTAGE PLIERS
Insulated long nose pliers made of high impact Bakelite. Absolutely shock-proof.
No. 8387 NET \$0.99



G-C ALIGNMENT BENCH KIT
Includes 16 most needed tools in handy stand-up bench rack.
No. 8281 NET \$7.74

GENERAL CEMENT MFG. CO.

910 Taylor Ave. • Rockford, Illinois

FREE! Postcard brings your big G-C Catalog.



G-C ALIGNMENT TOOL KIT
No. 9201 NET \$14.95



Ask Your Jobber
for the **G-C**
SPECIALS OF THE MONTH



G-C ALIGNMENT TOOL KIT
No. 9200 NET \$13.95

You'll want BOTH!

"Quick-Hot" ELECTRONIC SOLDERING GUNS

WEN

**WORKING HOT
IN 2-3 SECONDS**

LIGHT, HANDY
New Model #199
FOR GENERAL SERVICE

New patented design delivers AMPLE heat fast on 110-120 V. A.C. 60 cycle, 1.1 Amp. Max. Cools quickly too. It's light, (1½ lbs.)—handy, beautifully balanced and smaller—to slip readily into tool kit or pocket. Molded red plastic handle and case. Gun made to withstand

**HUNDREDS OF HOURS
CONTINUOUS OPERATION**

Almost indestructible in ordinary use. New type, steel, extra long reach tips easily replaceable and interchangeable with special tip that cuts plastic tile, etc. Gun fully guaranteed. Everyone who handles one wants one. And that PRICE—



Only \$7.95

LIST



**FAMOUS HEAVY DUTY
250 WATT
MODEL #250**

Greater volume of heat enables it to solder relatively heavy materials. Well balanced. Strongly made. (567 hours continuous operation.) Fully guaranteed. With special tip also cuts plastic tile, etc.

Only \$12.95



INDIVIDUALLY
BOXED

120 V. A.C. 60 CYCLE

WEN also makes 3 small powerful ELECTRIC SANDERS you'll want—fine finishing to heavy duty—\$13.95 to \$19.95 Complete Kit.

WEN PRODUCTS, INC.

5808 NORTHWEST HIGHWAY, CHICAGO 31, ILL.

(Export sales, Scheel International, Inc., Chicago)

RADIO

speaker for output. Two tubes are used in this version, a 1T4 regenerative detector and a 1S4 audio amplifier. Power comes from a 1.5-volt A battery and a 22.5-volt B battery (Fig. 2 shows a 15-volt battery, but 22.5-volt unit gave better performance), both feather-weight types. Three bands are covered, 250-480, 25-55 and 12-25 meters, with slug-tuned coils (Table 2). Controls are kept to a minimum, as too many knobs to twist can be a nuisance under blackout conditions. As with the first one, all components are miniature types including the audio transformer which measures 1 inch each way (a hearing-aid type, if available, would be ideal).

The chief claim to unorthodoxy in this little radio and the secret of its excellent performance lies in the use of a high L/C ratio on all bands. For

TABLE 2—Specifications, Fig. 2 coils.

Band	162 turns tapped at 112 from bottom. No.
BC	38 enameled
SW1	30 turns center-tapped. No. 30 enameled.
SW2	12 turns center-tapped. No. 24 enameled.

reasons connected with coverage, this is not usual on the broadcast band. But, as it enables a gain of some 25 db greater than that from a normal input arrangement.

In all other respects the circuit is quite standard, and in many cases, the few parts required will be found in the junk box. No particular instructions are necessary in regard to building beyond saying that with both receivers, the wiring should be kept as short as possible. 25 or 30 feet of

Parts for receiver in Fig. 1

Capacitors: 1—3-30 μ f, ceramic, mica or air dielectric, 1—15, 2-100 μ f, air, variable. 1—100 μ f, fixed, mica or ceramic.

Miscellaneous: 1—2-megohm resistor, 1—3-to-1 single-ended a.f. interstage transformer, 1—3A5 tube. Socket, dials, chassis, phones, phone jack, batteries, terminal strips, hookup wire, 2—1-inch diameter plug-in-coil forms, No. 24 wire for coils.

Parts for receiver in Fig. 2

Capacitors: 1—100, 1—160 μ f, variable, 2—100 μ f, fixed mica or ceramic.

Miscellaneous: 1—2.5-mh r.f. choke, 1—3.3-megohm resistor, 1—3-to-1 single-ended a.f. interstage transformer, 2—7-pin miniature tube sockets, 1—1T4, 1—1S4 tube; 1—2-pole, 3-position rotary switch, 1—s.p.s.t. toggle, slide or rotary switch; batteries, headphones or single earphone, hookup wire, No. 24, 30 and 38 wire for coils, chassis, and hardware.

rubber-covered, flexible wire makes a good antenna when flung over a tree, or wall, or even laid out on the ground, and can be wound round the case when not in use. The ground connection is 3 or 4 feet of the same material with a crocodile clip on the free end, which can be clipped to any ground point, or left trailing.

In conclusion, both these receivers, originally designed for serious purposes and still having that purpose in mind, will prove useful items to take along on vacation or camping trips, and will provide plenty of entertainment, especially for short-wave enthusiasts.

END

new Devices



NEW SECRET RECORDER camouflaged in average-size leather briefcase which may be opened, carried or put down without revealing recorder. Weighs 11 $\frac{3}{4}$ pounds; measures 16 x 4 $\frac{1}{4}$ x 12 $\frac{1}{2}$ inches. After

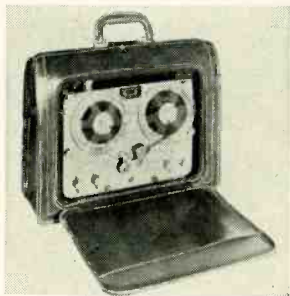

level has been preset, no further adjustments required. Automatic volume control equalizes nearby and distant sounds. Built-in microphone picks up whispers in quiet area at distance of 12 feet, ordinary speech at 100 feet. Combination slide lock and start-stop switch. Continuous recording for 1 $\frac{1}{4}$ hours at tape speed of 1 $\frac{1}{2}$ i.p.s. using long-play $\frac{1}{4}$ -inch magnetic tape; a 5-inch reel holds 3 hours of dual-track recorded material. Built-in pre-amplifier for headphone playback. Output into external amplifier and loudspeaker for greater playback volume.—**Amplifier Corp. of America**, 398 Broadway, New York, N.Y.

LONG-PLAYING TAPE, IRISH LP 600. Frequency response limited only by recording and playback equipment with 50% increase in playing time over standard tapes on same reel. New **Ferro Sheen** process for wider frequency range, less



background noise, greatly reduced dropout, higher fidelity, no needle noise, no deterioration in quality on repeated playing. Available in either 1-mil acetate or 1-mil Mylar.—**ORRadio Industries, Inc.**, Opelika, Ala.

TV CABLE TAPOFFS, Blonder-Tongue Masterline series model MTO-11 for community systems; model MTO-59 for indoor use. Air dielectric insulation

minimizes shunt capacitance. Uniform 17-db r.f. isolation, positive electrical protection through spring-contact resistor-capacitor network. MTO-11 handles RG-11/U



through-line, with clamp for messenger cable and RG-59/U fitting for tapoff line. MTO-59 taps into RG-59-U for TV outlets in hotels, apartments, etc. Wall outlet plate and RG-59/U receptacle included. Each tapoff has less than $\frac{1}{2}$ -db insertion loss.—**Blonder-Tongue Laboratories, Inc.**, 526 North Ave., Westfield, N. J.

TELESCOPING MASTS, Jontz Kwick-Up deluxe 100 series, made from hot-dipped galvanized tubing. Standard 200 series of tubing rolled from galva-

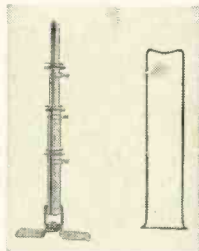

nized strip. Various o.d. sectional combinations. Mast sections will not pull apart; locking device enables speedier erection and locking without tools; guy ring; companion base to assure definite locking and eliminate turning in the wind.—**Jontz Mfg. Co.**, 1101 E. McKinley Ave., Mishawaka, Ind.

YAGI ANTENNA, LaPointe VeeDXer, all-channel v.h.f. type. High gain. High front-to-back ratio eliminates co-channel interference.

Yagi 18-element combines half-wave broadband Yagi on the low band with full-wave broadband Yagi on high. Phased together with VEE-D-X Dyna-phase system. Full-wave

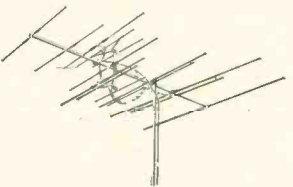

design for the high channels equals, on channels 7-13, gain

directivity and front-to-back ratio of single-channel 10-element Yagi.—**LaPointe Electronics Inc.**, Rockville, Conn.

FRINGE ANTENNA, Ward Invader, has flat type Inline Yagi for operation in fringe areas in v.h.f. range and in primary signal areas in u.h.f. range. Snap-lock bracket eliminates intermittent contact. Requires only 29



inches of stacking. Available in 4-bay stacking kit, model TV-357, and two-bay version plus stacking harness, model TV-356.—**Ward Products Corp.**, Division of Gabriel Co., 1148 Euclid Ave., Cleveland 25, Ohio.

NEW ANTENNA, Winegard Super 'Ceptor SL-4, a more powerful version of Winegard Inter-

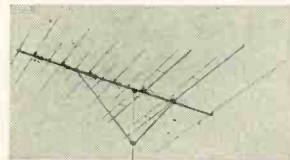

ceptor for difficult and extreme fringe TV areas. Multielement Yagi performance on all 12 v.h.f. channels. Modified Tee-matched driven elements phased to reinforce signals from front and cancel from back and sides. Uniform gain characteristics, absence of resonant peaks and suck-outs and high signal-to-noise ratio qualify antenna for color reception.—**Winegard Co.**, 3000 Scotten Blvd., Burlington, Iowa.

NEW AMPLIFIER, Lafayette LA-54, furnishes 12 watts. Frequency response, 20-20,000 cycles. Includes record equalizer with separate adjustable-base



turnover and treble rolloff; 16 playback characteristics; phono preamplifier; input for crystal, ceramic cartridges; special recording tape takeoff jack; FM (capacitance) input; good power output at very low and very high frequencies.—**Lafayette Radio**, 100 Sixth Ave., New York 13, N. Y.

PAPER TUBULAR CAPACITORS, Cornell-Dubilier STT Midget Budroc. Miniaturized versions of Budroc capacitors. Size range from 7/32 inch diameter and 11/16 inch length to $\frac{3}{8}$ and 1 $\frac{1}{2}$ inches, respectively. Rated up to 400 volts



d.c.: impregnated in HT compound; operating temperature range from -40° to +90° C. Rated at 600 volts d.c.: impregnated in Vikane; operating temperature range from -55° to +100° C.—**Cornell-Dubilier Electric Corp.**, South Plainfield, N. J.

CAPACITORS, Illini Ste-Tite, have very high insulation resistance, low power factor, long-life performance at high temperatures. Noninductively wound foil assemblies oil-impregnated and hermetically sealed in steatite cases. Over-



load tested, standard tolerance $\pm 20\%$. Thermoset end seals will not soften or flow with soldering or at any conceivable operating temperature. Available in capacitance ranges from .0005 to 1.0 μ f and in 200, 400, 600 and 1,600 working volts d.c. ratings.—**Illinois Condenser Co.**, 1616 N. Throop St., Chicago 22, Ill.

PICKUP CARTRIDGE, Astatic crystal phonograph types. Model 66 series: 3-volt output at 1,000 cycles, 1-megohm load; **68 series:** 4-volt output. Both types in single and double-needle turnover models. High compliance of model K needle, illustrated below, results in true tone, smooth response and absence of needle talk. Single-needle models: 1-mil needle tip

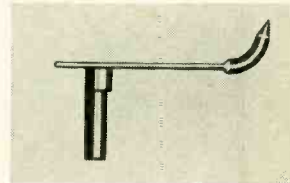

for slow-speed records; 3-mil, 78 r.p.m.; 2-mil, all record grooves. Easily replaceable without tools. Housings are stamped aluminum; terminals quick disconnect type. Crystal elements have moistureproof coating.—**Astatic Corp.**, Conneaut, Ohio.

MICROPHONE CARTRIDGES, Ronette Filtercel. Sensitivity at 1,000 cycles of 2.2-2.6 millivolts per μ bar, eliminating need for high-gain preamplifier. Range: 30-7,500 cycles. Available with almost any variation in frequency response desired.—**Ronette Acoustical Corp.**, 135 Front St., New York 5, N. Y.

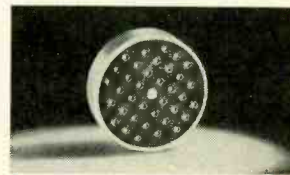

LIGHTNING ARRESTER, Radion LA75, handles all standard types of 300-ohm lead (open, jumbo, flat, tubular). UL approved for outdoor and indoor use. Utilizes sparkgap,

MAIL TODAY. LEARN RADIO AT HOME WITH THE PROGRESSIVE RADIO "EDU-KIT".

BUILD 15 RADIOS

ONLY

AT HOME \$19.95

Complete

With the New Improved 1955 Progressive Radio "EDU-KIT"

NOW INCLUDES
HIGH FIDELITY,
SIGNAL TRACER, and
CODE OSCILLATOR



- ATTRACTIVELY GIFT PACKED
- FREE SOLDERING IRON
- NO ADDITIONAL PARTS NEEDED
- EXCELLENT BACKGROUND FOR TV
- 30 DAY MONEY-BACK GUARANTEE
- SCHOOL INQUIRIES INVITED
- ABSOLUTELY NO KNOWLEDGE OF RADIO NECESSARY

WHAT THE PROGRESSIVE RADIO "EDU-KIT" OFFERS YOU

Our Kit is designed to provide a fundamental background in radio, with the basic facts of Radio Theory and Construction Practice expressed simply and clearly. You will gain a knowledge of basic Radio Principles involved in Radio Reception, Radio Transmission and Audio Amplification. You will learn how to identify Radio Symbols and Diagrams; how to build radios, using regular radio circuit schematics; how to mount various radio parts; how to wire and solder in a professional manner. You will learn how to service and trouble-shoot radios. You will learn code. You will receive training for F.C.C. Novice License. You will learn High Fidelity.

In brief, you will receive a practical basic education in Radio, worth many times the small price you pay.

THE KIT FOR EVERYONE

The Progressive Radio "Edu-Kit" was specifically prepared for any person who has a desire to learn Radio. The Kit has been used successfully by young and old in all parts of the world. It is not necessary that you have even the slightest background in science or radio.

The Progressive Radio "Edu-Kit" is used by many Radio Schools and Clubs in this country and abroad. It is used by Armed Forces Personnel and Veterans throughout the world.

The Progressive Radio "Edu-Kit" requires no instructor. All instructions are included. All parts are individually boxed, and identified by name, illustration and diagram. Every step involved in building these sets is carefully explained.

PROGRESSIVE TEACHING METHOD

The Progressive Radio "Edu-Kit" comes complete with instructions. These instructions are arranged in a clear, simple and progressive manner. The theory of Radio Transmission, Radio Reception, Audio Amplification and servicing by Signal Tracing is clearly explained. Every part is identified by illustration and diagram. You will learn the function and theory of every part used.

The Progressive Radio "Edu-Kit" uses the principle of "Learn by Doing". Therefore you will build radios, perform jobs, and conduct experiments to illustrate the principles which you learn. These radios are designed in a modern manner, according to the best principles of present-day educational practice. You begin by building a simple radio. The next set that you build is slightly more advanced. Gradually, in a progressive manner, you will find yourself constructing still more advanced multi-tube radio sets, and doing work like a professional Radio Technician. Altogether you will build fifteen radio circuits, including Receivers, Transmitter, Code Oscillator and Signal Tracer. These sets operate on 105-125 V. AC/DC. An Adaptor for 210-250 V. AC/DC operation is available.

THE PROGRESSIVE RADIO "EDU-KIT" IS COMPLETE

You will receive every part necessary to build 15 different radio circuits. Our "Edu-Kit" contains tubes, tube sockets, chassis, variable, electrolytic, and paper condensers, resistors, line cord, selenium rectifier, tie strips, coils, hardware, tubing, etc.

Every part that you need is included. These parts are individually packaged, so that you can easily identify every item. A soldering iron is included, as well as an Electrical and Radio Tester. Complete, easy-to-follow instructions are provided. All parts are guaranteed, brand new, carefully selected and matched.

In addition, the "Edu-Kit" now contains lessons for servicing with the Progressive Signal Tracer, F.C.C. instructions, quizzes, high fidelity instructions.

TROUBLE-SHOOTING LESSONS

Trouble-shooting and servicing are included. You will be taught to recognize and repair troubles. You will build and learn to operate a professional Signal Tracer. You receive an Electrical and Radio Tester, and learn to use it for radio repairs. While you are learning in this practical way, you will be able to do many a repair job for your neighbors and friends, and charge fees which will far exceed the cost of the "Edu-Kit". Here is your opportunity to learn radio quickly and easily, and have others pay for it.

FREE EXTRAS

- ELECTRICAL & RADIO TESTER ● ELECTRIC SOLDERING IRON ● TV BOOK ● QUIZZES

Progressive "Edu-Kits" Inc. 497 Union Ave., Brooklyn 11, N.Y.

MAIL TODAY—Order shipped same day received.

30-Day Money-Back Guarantee. Include ALL FREE EXTRAS

- Send "Edu-Kit" Postpaid. I enclose full payment of \$19.95 (U.S.A. only).
- Send "Edu-Kit" Postpaid. I enclose full payment of \$20.95 (Outside U.S.A.).
- 210-250 V. Adapter for "Edu-Kit"—\$2.50.
- Send "Edu-Kit" C.O.D. I will pay \$19.95 plus postage (U.S.A. only).
- I wish additional information describing "Edu-Kit". No Obligation.
- Send me FREE Radio-TV Servicing Literature. No Obligation.

Name.....

Address.....

PROGRESSIVE "EDU-KITS" INC.

497 UNION AVE., RM 103 G, PROGRESSIVE BLDG., BROOKLYN 11, N.Y.
On Shipment to a New York City Address, add 60c sales tax

BUILD 15 RADIOS AT HOME WITH THE PROGRESSIVE RADIO "EDU-KIT". MAIL TODAY

NEW DEVICES

resistor circuit (technically safest). Includes mounting strap and hardware; features

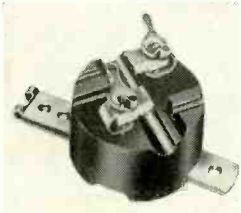

Radion ground wire grip.—The Radion Corp., 1130 W. Wisconsin Ave., Chicago 14, Ill.

LIGHTNING ARRESTER and lead-in tube. Telco 8644, for mobile home television installations. Can be installed in 3/4-

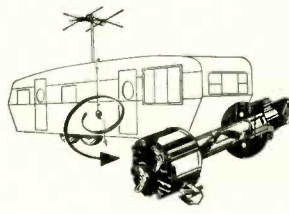

inch hole in trailer wall and lead-in tube pushed through the hole.—Television Hardware Mfg. Co., Division of General Cement Mfg. Co., 919 Taylor Ave., Rockford, Ill.

DUAL-RANGE D.C. POWER SUPPLY, *Electro Products model EF*, has continuously variable source for 0-14 and 0-28 volts for all loads 0-5 amperes, with a.c. ripple of less than 1% at 5 amperes. Intermittent loads to 10 amperes obtainable. Exact current and voltages indicated on D'Arsonval type

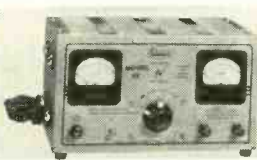

meters. Single control for continuous adjustments for different load conditions over specified range. Has 115-volt 50-60 cycle input, 265 watts at 28 volts, 5 amperes; choke input and pi type filters with 2 chokes and 2 2,000- μ f capacitors; bridge type selenium rectifiers; heavy-duty control transformer for incremental voltage adjustment. *Model E* operates with less than 5% ripple at 5 amperes.—*Electro Products Laboratories, Inc.*, 4503 N. Ravenswood, Chicago 40, Ill.

FM RECEIVER KIT, *Approved V-9*, for an individual binaural or high-fidelity installation. Self-contained a.c. power sup-

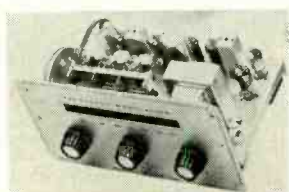

(Continued)

ply; tuning range 88 to 108 mc; bandwidth 200 kc; two limiters and discriminator; sensitivity 10 μ v, 20 db; tuned r.f. stage; 3-section variable capacitor.—*Approved Electronic Instrument Corp.*, 928 Broadway, New York 10, N. Y.

V.T.V.M. KIT, *Heath model V-7*, has printed-circuit board for reduced assembly time and constant circuit performance.

Has 7 a.c. (r.m.s.) and d.c. voltage ranges of 1.5, 5, 15, 50, 150, 500, 1,500; 7 peak-to-peak a.c. voltage ranges of 4, 14, 40, 140, 400, 1,400, 4,000; ohmmeter ranges of $\times 1$, $\times 10$, $\times 100$,

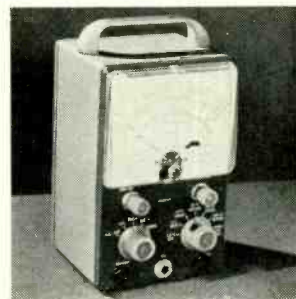

$\times 1,000$, $\times 10,000$, $\times 100,000$, and $\times 1$ megohm. Db scale provided, zero-center operation within range of front panel controls. 4 1/2-inch meter, 1% precision resistors. a.c. power supply. Easily assembled in few hours. Peak-to-peak voltages read directly on meter face without calculation. Has 11-megohm input impedance.—*Heath Co.*, Benton Harbor, Mich.

TUBE TESTER KIT, *Knight*, measures tube performance by cathode-emission method. Checks for shorted elements, open elements, heater continuity. Tests 4-, 5-, 6- and 7-pin large, regular and miniature types; octals, loctals, 9-pin miniatures and pilot lamps. Has 4 1/2-inch meter, line-voltage compensator, roll chart. Universal socket pin selectors permit testing, without wiring

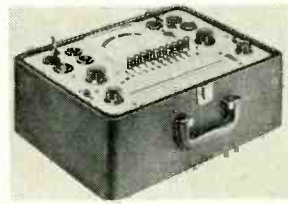

changes, tubes with new base arrangements. Roll chart removable for addition of new-tube testing data. Blank socket provided for future use. Single-unit 10-lever function switch simplifies assembly.—*Allied Radio Corp.*, 100 N. Western Ave., Chicago 80, Ill.

TV OSCILLOSCOPE, *National Radio Institute model 56*, for industrial applications where square-wave and pulse type signals must be observed.

Vertical amplifier response flat from 10 cycles to 45 mc (± 3 db). Four-step frequency-compensated vertical attenuator calibrated for direct peak-to-peak voltage measurement. Sensitivity .014 volt (r.m.s.) per inch of deflection. Linear sweep

NEW DEVICES

range 10 cycles to 100 kc. Average vertical amplifier input impedance 2 megohms, and 25 μ mf. Positive and negative sync,



voltage-regulated power supply.—National Radio Institute, 16 & U Sts., Washington 9, D. C.

POCKET TUBE CHECKER, Senco FC-3, weighs less than 6 ounces. Checks filaments (or heaters) of all octal, loctal, 7- and 9-pin tubes, including all

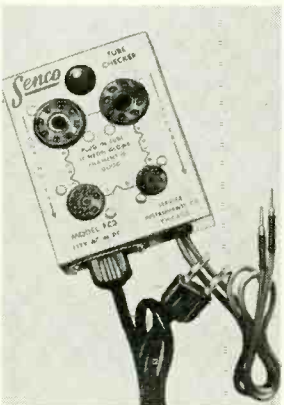

new 600-ma tubes used in series-filament TV sets.—Service Instruments Co., 422 S. Dearborn St., Chicago 5, Ill.

GARAGE DOOR OPENERS, Alliance Lift-A-Dor, electrical and radio control. *Genie models KST-1*, key lock, straight track; *HST-1*, hydraulic straight track;



CT-1, curved track; *RCST-1*, radio-controlled straight track, and *A*, completely automatic radio-controlled, which opens and closes door, turns light on and off, locks and unlocks door, operates from car dash, and is set with individual transmitter.—Alliance Mfg. Co., Alliance, Ohio.

SOLDERING IRON, Esico Luger, has lightweight Luger

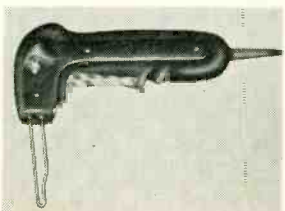

(Continued)

grip and fast-heating tip. Dual or single heat. Loop tip heats quickly, reaches hard-to-get-at places easily. Twin lights illuminate work, eliminate shadows. Rests on its side when not in use, needs no stand.—Electric Soldering Iron Co., Deep River, Conn.

INSULATING LACQUER, Insl-X A-11, acts as binder for pie-wound coils; as sealant for plastic-molded units, oil-filled capacitors, and decals on phenolic surfaces, and as general-purpose high-quality adhesive. Supplied in colors and clear. Used for color-coding such units as ceramic capacitors subject to high operating temperatures. High dielectric strength and adhesion. Applied by brushing or dipping.—Insl-X Sales Co., 26 Rittenhouse Place, Armore, Pa.

TVI FILTER, Federal 3-Pi, features new precision-engineered printed circuit designed to suppress interference from ignition systems, medical diathermy and X-ray equipment, neon



signs, amateur radio transmitters, electrical appliances. Transparent polystyrene plastic case 0-54-mc attenuation above 46 db.—Federal Electronics, Federal Electronics Bldg., Rockville Centre, N. Y.

FUSE RESISTOR, Ohmite FR-75, replaces any fuse resistor in TV receivers. 7½ ohms. Fur-

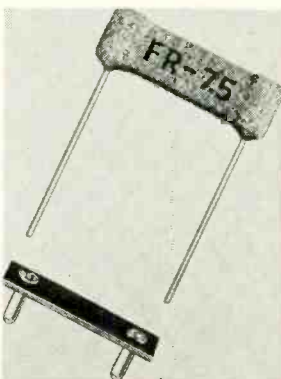

nished with 1½-inch tinned wire leads plus separate plug-in mounting strip. Can be soldered to strip for plug-in mounting or directly into circuit under chassis.—Ohmite Mfg. Co., 3675 Howard St., Skokie, Ill.

HI-FI CABINETS, REGENCY TM, table model with pre-cut, pre-drilled panels, can be used for Regency HF 80 or HF 150 amplifiers. Companion piece available for Regency tuners. *Model TMC* designed for HF 80 or HF 150 amplifier or AF 220 tuner, with any standard record

METERS with an EXTRA MEASURE OF VALUE

EMC VOMS AND VTVMS feature ...

- LOWEST PRICES
- PRECISION CONSTRUCTION
- VERSATILE, ADVANCE DESIGNS
- WIDEST INSTRUMENT CHOICE

EMC MODEL 102 VOLOMETER*



• Sturdy, pocket-size case • Large, clear 3"—1000 ohms per volt D'Arsonval-type volt meter—2% accurate • 5 AC&DC voltage ranges, 0-3000V. • 4 DC current ranges, 0-1.2 amps. • 3 AC current ranges, 0-600 ma. • Two resistance ranges with same zero adjustment

Model 102\$14.90

EMC MODEL 104 VOLOMETER*



• 5 DC voltage ranges (20,000 ohms per V.), 0-3000 V. • 3 AC & DC current ranges • Extra large, easy-to-read 4½", 50 micro-amp. meter with alnico magnet • 3 resistance ranges • 5 DB ranges —4 to +67 • 3 AC current ranges, 0-600 ma. • 4 DC current ranges, 0-1.2 amps. • 5 AC voltage ranges (1000 ohms per V.), 0-3000V.

MODEL 104 (With carrying strap).....\$26.95

*Reg. Trademark for volt-ohm milliammeter

EMC MODEL 107 VTVM



Directly measures capacity, resistance and complex waveforms peak to peak • uses an electronic balanced push-pull circuit and peak to peak rectification • measures directly in 6 ranges • all peak to peak voltages of complex waveforms • between .2 volt and 2800 volts-RMS values of sine wave voltages • between .1 volt and 1000 volts-capacity of condensers between 50 MMFD to 5000 MFD • resistance from .2 ohms to 1000 megohms.

MODEL 107 (complete with leads) \$48.90

MODEL 107 (kit form) \$34.50

Accessory probes available

"EYE LEVEL" INSTRUMENT STAND FOR ALL METERS \$.98

Extremely sensitive EMC meters give you accurate "in service" readings for easy servicing. Carefully designed for field and shop work these meters prove you save more... service better with EMC precision instruments.

FREE-complete catalog of instruments write Dept. RE-4 TODAY!

ELECTRONIC MEASUREMENT CORP. **EMC**

280 LAFAYETTE STREET NEW YORK 12, N. Y.

EXPORT DEPT.— 136 LIBERTY ST. N. Y. 6, N. Y.

©NTI



The Word We Dreaded

My husband and I were together when the phone rang. He got up to answer it and I held my breath as I heard his quiet, "Yes, Doctor?"

Then he put the receiver down carefully. His face, when he turned to me, was gaunt and lined, but he was trying to smile.

"Was it—the laboratory tests?" I asked.

He nodded. "We'd better get my bag packed," he said gently. "They want me in the hospital this evening."

We had realized for months that something was wrong. But the pressure of his business postponed action. "Guess I'm a little off my feed," was all he would say.

It took our family physician only ten minutes to change that attitude. He made an immediate appointment with a specialist. And at the end of an anguished week we knew. The laboratory tests confirmed the word we dreaded—"Cancer."

That was a year ago. Modern cancer research saved my husband. That... and the surgeon's skill, the strength of our faith and his own fighting heart. He is alive and well today. For us the story has had a happy ending.

Yet it *isn't* ended. When we think of the thousands of other families tragically broken every year, we feel we still have work to do. Many types of cancer *can be cured* if caught in time.

We tell our friends, "If there are symptoms you don't understand, see your doctor at once." And we *give* to support the constant research of the American Cancer Society in finding the causes and reducing the incidence of cancer.

American Cancer Society

GENTLEMEN:

I want to help conquer Cancer.

Please send me free information about Cancer.

Enclosed is my contribution of \$_____ to the Cancer Crusade.

Name _____

Address _____

City _____ Zone _____ State _____

(MAIL TO: CANCER, c/o your town's Postmaster)

Strike back at CANCER... man's cruelest enemy... GIVE

NEW DEVICES

(Continued)

changer. Optional wrought-iron legs for conversion to console model. Model CTC adaptable to any Regency amplifier or tuner, and any record changer. Re-

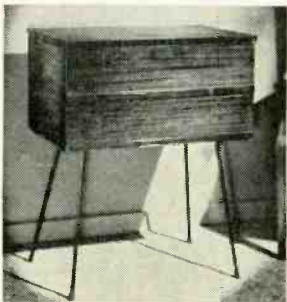

gency, Division of I.D.E.A. Inc., 7900 Pendleton Pike, Indianapolis 25, Ind.

REPLACEMENT FLYBACKS, Stancor A-8253, A-8254, A-8255, replace Admiral parts 79D48-1,

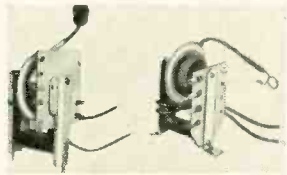

97C60-1, 70C60-A, respectively. Exact electrical and physical duplicates of the units they replace.—Chicago Standard Transformer Corp., Standard Division, Addison & Elston, Chicago 18, Ill.

MICROPHONE STAND, Atlas Porta-Boom, is collapsible to easily transportable size; quick to knock down and set up. Features piston air-check mechanism

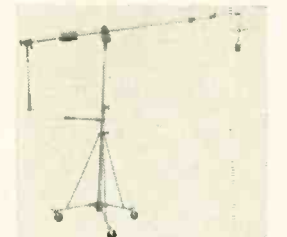

permitting rapid height adjustment without danger of sudden downward motion. Two-position dual control rotates mike through 360°; suspension is noise-free and positioning automatic at all boom angles.—Atlas Sound Corp., 1451 39 St., Brooklyn, N. Y.

TUBE SOCKET ADAPTER KIT, Vidair AT-K, contains three Adap-Test units: AT-1 for all octal tubes; AT-2 for 7-pin miniatures; AT-3 for 9-pin miniatures. Test points numbered for identification. Extension



leads 20 inches long reach all tube sockets.—Vidair Electronics Mfg. Corp., 576 W. Merrick Rd., Lynbrook, N. Y.

AUTOMATIC CHANGER NEEDLE BRUSH. Robins KLee-NeedLE, keeps needles clean, removes dust from under needle

point, prevents it accumulating on needle and causing distortion and poor fidelity.



Dust is removed each time tone arm moves, wiping needle over KLeeNeedLE brush. Height adjustable. fits most record changers. Fastened by pressure-sensitive adhesive supplied.—Robins Industries Corp., 82-09 251 St., Bellerose 26, N. Y.

MIGHTY MIDGET INVERTERS, ATR, for portable use equipped with cigarette lighter cord sets. Use on 6- or 12-volt storage battery systems simply by plugging into cigarette lighter receptacle on dash. De-



liver 110 volts a.c., 60 cycles; output as high as 100 watts. Useful for operating dictating machines, small tape recorders, etc.—American Television & Radio Co., 300 E. 4th St., St. Paul 1, Minn.

TV TUBE BRIGHTENER rejuvenates dim picture tubes. Operates on all types of pic-



ture tubes—magnetic or electrostatic—and in all circuits—parallel or series.—Mail Mart, Dept. RE, 526 S. State St., Springfield, Ill.

FM TUNER, Browning Brownie model CL, has GE Telechron clock-timer unit installed in a cabinet complete with 3-way a.c. outlet, making it possible to preset tuner to turn a complete high-fidelity system on or off automatically.—Browning Laboratories, Inc., Winchester, Mass. END

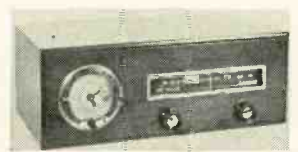

All specifications given on these pages are from manufacturers' data.

THIS IS IT!

TEST EQUIPMENT YOU CAN'T BEAT FOR
VALUE — PERFORMANCE — PRICE

RCP

ONLY \$39.75 net

Fast, reliable testing of flyback transformers and yokes

The original FLYBACKER

Incredibly sensitive, the model 123 Flybacker, made ONLY by RCP, immediately shows up a shorted turn in a flyback transformer or yoke. The light, portable design serves to advantage in the home as well as the shop. All tests can be carried out under operating conditions with the common substitutes in place in the TV receiver. Only RCP makes the Flybacker.



RCP

MODEL 123

ONLY \$14.85 net

All molded—

unequaled

by any other in its class

ready to operate

AC-DC MULTITESTER

Greater multimeter value than ever before at a far lower price. 3" square meter with 800 ampere D'Arsonval movement gives 1000 ohms per volt sensitivity on DC. Battery for ohmmeter circuit is readily removable and replaceable without soldering or unsoldering. Truly a must for every laboratory, shop and serviceman's kit; its smart appearance is matched only by its high performance.



RCP

MODEL 480

ONLY \$51.95 net

Meets all today's needs...

plus tomorrow's color requirements

Portable TUBE TESTER

Positively the greatest testing performance ever built into a tube tester. Tests all tubes in current radio and television receivers, as well as in color TV receivers. Gaseous rectifiers, hearing aids, ballasts, With CR adapter cable (available at slight additional cost), will check CR picture tubes... both black and white and color.

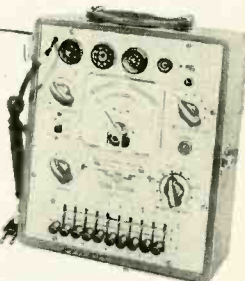

RCP

MODEL 327P

See your distributor or write department RE-4 for latest RCP catalog.

RADIO CITY PRODUCTS CO., INC.



EASTON, PENNSYLVANIA

AMPHENOL

antennas & accessories for clearer, sharper pictures...

ANTENNAS

A complete selection of high-gain, top-quality VHF and UHF antennas is offered by AMPHENOL. The color-tested INLINE (Reissue U.S. Pat. 23,273) is still the outstanding VHF antenna today, features high, level gain and stay-up construction. The Corner Reflector, installer's model Lightweight Corner Reflector and the Bo-Ty are superior UHF antennas—exceptionally sturdy, exceptionally high gain. The Stacked-V is a quality VHF/UHF all-channel antenna.

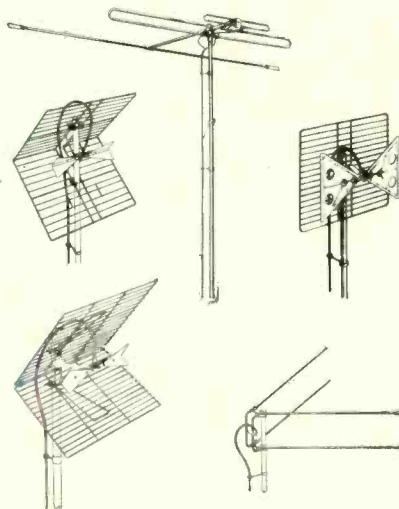

ACCESSORIES

Every accessory needed for the quality tv antenna installation is available from AMPHENOL. Lightning Arrestors (with and without pipe-mounting strap); Isolating Networks: Isonet for VHF and UHF, Duonet for Hi-VHF and Lo-VHF, and the Trisonet for Hi-VHF, Lo-VHF and UHF—all three of these accessories effectively isolate antennas for different frequencies, couple them into a single lead-in. The Tele-Couplers, in two and four set models, couple up to four tv sets to a single antenna lead-in. The new High Pass Filter effectively eliminates tv interference by passing only signals at frequencies above 50 mc.

LEAD-IN

Dependable standard Flat Twin-lead and unique AIR-CORE Tubular Twin-lead have been joined by several new lead-ins to make the AMPHENOL line the most complete available. New Century and Heavy-Duty Twin-Leads are deluxe VHF lead-ins; AIR-CORE transmitting Tubular Twin-Lead has been reinstated, as has Four Conductor Rotator Cable.

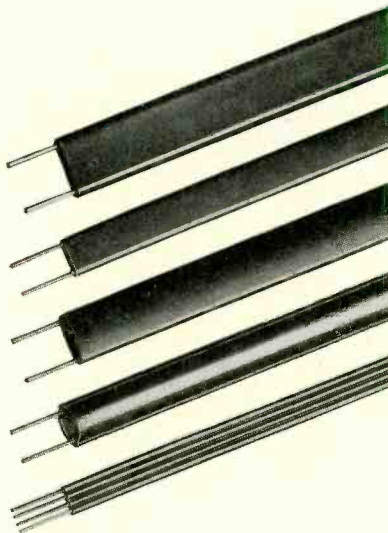

AMERICAN PHENOLIC CORPORATION

chicago 50, illinois

AMPHENOL

In Canada: AMPHENOL CANADA LIMITED, Toronto

new Tubes & Transistors



New projection tube

RCA has announced the 5AZP4, a television projection tube capable of providing auditorium-size 8 x 6-foot pictures. The tube uses electrostatic focus and magnetic deflection. This type focus simplifies the use of the tube with a reflective optical system. The 5AZP4 has a metal-backed white fluorescent screen.

Operating with a maximum second-anode voltage of 40,000 and a maximum focusing-electrode voltage of 8,600, the 5AZP4 features a molded-on second-anode connection cable 48 inches long; a bulb with insulating coating to minimize leakage over its external surface under conditions of high humidity; a gun structure using anti-corona thimbles to prevent internal arcover and stray emission; only one high-voltage envelope connection—other connections are made through a plastic-filled duodecal seven-pin base.

The projection tube is intended primarily for closed-circuit applications, such as demonstration, training and educational work by business organizations and schools.

2N104 junction transistor

A hermetically sealed germanium-alloy junction transistor, the 2N104, has been announced by RCA. The semiconductor is of the p-n-p type intended for low-power audio applications. It is 1/4 inch in diameter and 11/16 inch in overall length.

The design of the 2N104 features a low base-lead resistance which minimizes ohmic losses, improves frequency response and provides high input-circuit efficiency. In a common-emitter circuit, it has a collector-to-base current amplification ratio of 44, a matched-impedance low-frequency power gain of 40 db and a collector-to-base alpha frequency cutoff of 13.9 kc. An unusually low noise factor of 12 db contributes to the dependable performance of this transistor in most low-level audio applications. The collector dissipation of the 2N104 is approximately 35 milliwatts.

5894

A small, sturdy, twin-beam power tube, the 5894, has been announced by RCA. It is intended primarily for use as a push-pull r.f. power amplifier or as a frequency tripler in fixed and mobile equipment operating in the u.h.f. range between 450 and 470 mc.

The 5894 has a maximum plate dissipation rating of 40 watts under CCS

NEW TUBES & TRANSISTORS (Continued)

conditions. In class-C telegraphy and frequency-modulated amplifier service at 470 mc, the tube can deliver a useful power of approximately 55 watts, measured at the output circuit load. As a tripler to 462 mc, it can deliver about 16 watts.

The high efficiency obtainable with the 5894 in conventional push-pull circuits, even at frequencies as high as 500 mc, is made possible by: the balanced, compact structure of the beam-power units which have low interelectrode capacitances; internal neutralization; close electrode spacing; a cathode common to the two units.

TV check tube

Sylvania has announced a new television receiver check tube (see photo), the 5AXP4. It is a 5-inch round, magnetically deflected tube using electrostatic self-focusing.

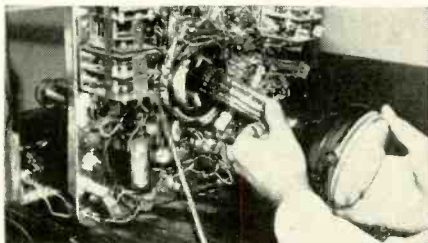

The 5AXP4, intended primarily for TV service technicians and equipment manufacturers, will permit a cabinet-mounted picture tube to be left in the cabinet while the receiver is being serviced in the shop. It is a universal type tube that can be inserted into almost any TV chassis while the set is being serviced (see photo).

The tube contains a built-in focus system and so does not require any focus device or ion-trap magnet while making tests on a receiver. The 5AXP4 is so light that the yoke of the receiver very easily supports the tube. The only electrical connections required are the high-voltage lead and the picture-tube socket of the receiver. The tube can be used in any receiver, regardless of the deflection angle.

10-kw klystron

One of the higher-priced tubes of the season, a new high-power u.h.f. amplifier klystron (see photo), the Eimac 3K50,000LQ, has been announced by Eitel-McCullough, San Bruno, Calif.

In CW operation at 850 to 1,050 mc, the tube delivers 10 kw output with



only 10 watts drive—a power gain of 1,000. It features resonant cavities completed outside the vacuum system, free of r.f. circuitry. This permits wide-range tuning and simple input and output coupling. For those interested, the klystron sells for \$4,200. **END**

**ELIMINATE CALL BACKS
ON RESISTOR REPLACEMENTS**

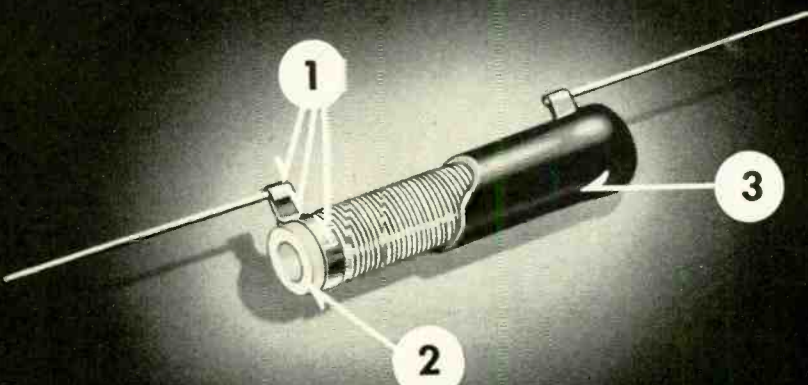

OHMITE
"Brown Devil"®
RESISTORS
have **BALANCED**
THERMAL EXPANSION

1 PATENTED WELDED TERMINALS

Ohmite welded terminals provide a perfect and permanently stable electrical connection that is unaffected by vibration or high temperature.

**2 HIGH TEMPERATURE
STEATITE CORE**

This strong, rugged steatite core has excellent electrical characteristics, and a coefficient of thermal expansion that matches the other resistor materials.

**3 EXCLUSIVE HIGH TEMPERATURE
VITREOUS ENAMEL**

This special-formula enamel was developed by Ohmite after extensive research. Its thermal expansion is properly related to that of the steatite core, terminal, and resistance wire.

Ohmite has carefully matched the thermal expansion of all parts in these resistors. This eliminates the possibility of enamel cracking, keeps terminals firmly anchored, and prevents the entrance of moisture. On your next repair job calling for new resistors, put your mind at ease—install Ohmite "Brown Devil" resistors. Available in 5-, 10-, and 20-watt sizes.

Be Right with
OHMITE®
DEPENDABLE RESISTANCE UNITS



Write for Stock Catalog

OHMITE MANUFACTURING CO.
3646 Howard St., Skokie, Ill.
(Suburb of Chicago)

Your
High
Fidelity
System
Will
Sound
Better
with a

**GOODMANS
Loudspeaker**

made in
england

ROCKBAR CORPORATION Dept. HD-9
215 East 37th Street, New York 16, N. Y.

Please send complete description of
Goodmans High Fidelity loudspeakers.

Name.....

Address.....

City..... Zone..... State.....

My Dealer is.....



N. Y. LECTURE SERIES

A lecture series for New York radio and TV technicians was scheduled for the late winter and spring by the Empire State Federation of Electronic Technicians Associations at their January meeting in Binghamton.

The initial lecture—on a transistor portable radio—was scheduled for New York City in February, to be given subsequently in the Buffalo-Western New York, Syracuse-Binghamton and Kingston areas. Succeeding lectures would follow the same route.

The Binghamton meeting also went on record as favoring action that would pave the way for unity on a national level among service organizations. To this end, and with the concurrence of Ferdinand J. Lynn of Buffalo, Eastern vice president of NATESA, and Max Liebowitz, president of NETSDA, who were present, it is urged by ESFETA that committees representing both groups as well as any other interested group meet in the near future to develop such unity.

A REAL SERVICE AID

A single sheet, containing on one side the schematic and on the other the tube placement diagram and most necessary service information, is inserted in the service data brochure on RCA's recent chassis KCS93 (models 17-S-450R, -451R and -453R). This "field service data sheet" is for the technician's convenience on home calls, giving him the information he is likely to need without the necessity of handling a multipage service data folder, as well as permitting the folder to remain in the shop for bench use.

This is a real step forward in the dispensing of service information.

YOU CAN SERVICE RADIO!

The story of the little girl who asked her teacher: "What's a radio?" is paralleled in dead seriousness by the Associated Radio-Television Service Dealers News of Columbus, Ohio. In a short paragraph recommending a recent book on radio receiver servicing it says, "Many of our members in their enthusiasm for TV are overlooking this source of income. If you can service TV, you can service a radio. This book will greatly help you understand just what goes on in a radio."

Maybe RETMA can be prevailed on to organize courses in radio servicing for TV technicians?

EXPERIMENTERS • HAMS • TECHNICIANS

MAKE YOUR OWN PRINTED CIRCUITS

Complete Kit \$19⁵⁵_{ppd.}

- USE MODERN TECHNIQUES
- MAKE CIRCUIT BOARDS TO YOUR OWN DESIGN
- CONTAINS ALL MATERIALS NEEDED TO MAKE SEVERAL BOARDS
- COMPLETE, STEP-BY-STEP INSTRUCTIONS
- SIMPLE EASY PROCEDURE FOR LAYOUT

Make your newest design idea and layout in printed circuit techniques. Build complete, lightweight circuitry with professional appearance and finish. Kit contains complete materials and equipment—nothing else to buy. Completely replenishable at low prices, list included. MONEY BACK GUARANTEE.

Send Check or Money Order to Dept. E-1

TELE-DIAGNOSIS CO.

155 WEST 72 STREET NEW YORK 23, N. Y.

Watch for the
May Issue of
RADIO-ELECTRONICS
on Sale April 26

Save time—Step up
efficiency in
**ELECTRONICS
DESIGN**



Here's a wealth of technical help for efficiently handling electronics design problems—help that gives you answers already worked out by the country's top electronics men—help that can save you hours of research and experimentation!

You'll find electronics mathematics and theory in concise form—design practices for hundreds of pieces of electronics equipment—and even the results of advanced electronic experiments. Radio, television, facsimile, sound, and scores of other phases of electronics are covered—and it's all condensed, classified, and indexed for quick, easy use.

ELECTRONICS DESIGN LIBRARY

Edited by Markus and Zelfuff, Electronics Magazine
4 vols., 2151 pp., 9 x 12, 3534 illustrations

Contains 1083 articles culled from recent issues of *Electronics*—the cream of information essential

to design of electronics equipment. The 4 big volumes are: *Electronics for Engineers, Handbook of Industrial Electronic Circuits, Electronics Manual for Radio Engineers, and Electronics for Communication Engineers.*

Special price
saves you \$6.00

Regular catalogue price of books totals \$39.00; under this offer, price is only \$33.00, on easy terms.

EASY TERMS!

10 DAYS' FREE EXAMINATION

McGraw-Hill Book Co., Inc., Dept. RE-4
330 West 42nd St., New York 36, N. Y.

Send me for 10 days' examination the **ELECTRONICS DESIGN LIBRARY**. In 10 days I will remit \$8.00, plus few cents delivery, then \$5.00 a month until \$33.00 is paid. If not satisfied, I will return books postpaid. (We pay delivery if you remit with this coupon; same return privilege.)

(PRINT)

Name.....

Address.....

City..... Zone..... State.....

Company.....

Position.....

For price and terms outside U.S. write McGraw-Hill Int'l., N.Y.C. RE-4

THE #630 TV RECEIVER remains unmatched for quality and performance • • • RCA designed and developed this set quality-wise *not* price-wise • • • The original 10" set retailed at \$375.00 • • • Subsequent TV sets serve to prove the sacrifice of quality for price • • • what better proof can there be of its superiority than the fact that it is the choice of TV engineers and TV technicians! Herewith we offer you—YOUR BEST BUYS IN TV!—All you pay is the price shown • • • Excise taxes have already been paid by us.

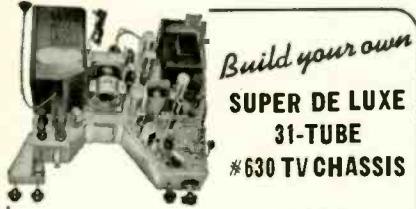

Build your own
SUPER DE LUXE
31-TUBE
#630 TV CHASSIS

#630 SUPER DE LUXE 31-TUBE TV KIT
Engineered in strict adherence to the genuine RCA #630 plus added features • • • OPERATES 16" to 24" PICTURE TUBES • • • CASCADE TUNER • • • COSINE YOKE • • • LARGER POWER TRANSFORMER • • • KEYS AGC • • • 12" SPEAKER • • • CONDENSERS and RESISTORS at rated capacities and tolerances. You receive a COMPLETE SET OF PARTS AND TUBES. Everything needed is included, (less CRT and wire.) You will enjoy building it with "LIFE-SIZE" easy to follow step-by-step ASSEMBLING INSTRUCTIONS" included with each KIT.

slashed to **\$99.99**

#630 SUPER DE LUXE TV CHASSIS

LICENSED UNDER RCA PATENTS
COMPLETE READY TO PLUG IN AND PLAY—
Similar in characteristics and features to the TV KIT above • Manufactured especially for us by nationally known manufacturers • No efforts or expense have been spared in workmanship or materials, to make this #630 SUPER DE LUXE TV CHASSIS the best obtainable for fringe areas, clarity and all-around-performance. Customers report reception better than 200 miles. Each set is factory aligned and air-tested • All parts carry the ISMA three month guarantee • Our mass volume of business on this CHASSIS (numbering thousands of pleased customers) now makes it possible for us to reduce the price. (less CRT.)

slashed to **\$142.27**

We Also Sell The **TECH-MASTER**
Complete Line of #630 TV CHASSIS. Catalog mailed on request.

Modernize a #630 or any TV Set
with a **STANDARD CASCADE TUNER**
For better all around performance
Complete with tubes and Brooks CASCADE MANUAL with step-by-step instructions and all extra parts needed. **\$17.97**

UNIVERSAL Picture TUBE MOUNTING **BRACKETS**
Fits All 12 1/2" to 21" picture tubes
Complete — Including band that holds picture tube
\$4.97

PULSE KEYED AGC KIT
Finest, most accurate and the easiest Kit to install in a #630 or in any other make TV receiver. Improves performance, and insures a steady picture on all channels.
COMPLETE SET OF PARTS \$2.99
Including 6AU6 tube & Instructions

SELENIUM RECTIFIER 75ma.	\$.56
SELENIUM RECTIFIER 100ma.	.69
SELENIUM RECTIFIER 150ma.	.74
SELENIUM RECTIFIER 300ma.	1.28
SELENIUM RECTIFIER 500ma.	1.78
AUDIO OUTPUT TRANSFORMER (50L6)	.29
AUDIO OUTPUT TRANSFORMER (6K6)	.49
PHONO MOTOR 3 speed, complete with t.t.	4.19
PHONO AMPLIFIER, incl. 3 tubes.	4.68
TV POWER TRANSFORMER, 250ma.	3.98
TV 21 inch mask.	1.92
TV BACK CUP, for recessing CRT	.29
RCA FLYBACK TRANSFORMER, doubler type	1.17
GEN. ELECTRIC AGC WIDTH COIL	.19
TV 90° DEFLECTION YOKE	5.98
TV FLYBACK TRANS. for 90° TV Chassis	4.42
TV PICTURE TUBE BRIGHTENER, complete	.69
REGENCY \$49.95 UHF CONVERTER, Comp.	19.97
#630 CHASSIS PAN, with sockets on	5.94

CUSTOM-BUILT CABINETS FOR #630 AND ALL OTHER TV SETS

From Factory to You

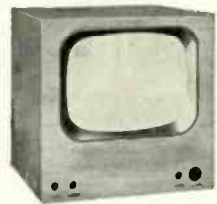

The VOGUE
H-25", W-26", D-22"

\$35.91



The FUTURAMIC
H-37", W-28", D-24 1/4"

\$79.34



The MAYFAIR
H-40", W-26", D-25"

\$88.70



The MANHATTAN
H-41", W-25", D-23"

\$53.43

4 LEADING STYLES in genuine mahogany or walnut (blond 10% extra)
• Ready drilled for any #630 TV chassis and cutout for any 16", 17", 19", 20" or 21" picture tube at no extras in price • Also supplied with undrilled knob panel for any other TV set • EVERYTHING NECESSARY for an easy perfect chassis and CRT assembly is included • Each cabinet is delivered complete as pictured with mask, safety glass, mounting brackets, backboard, backup, hardware and assembling instructions • Each cabinet is shipped in an air cushioned carton from FACTORY to YOU!

NATIONALLY KNOWN BRAND PICTURE TUBES

BRAND NEW in Factory Sealed Cartons—With a Full Year Guarantee

17" #17BP4A **\$26.66** | 21" #21EP4B Aluminized **\$39.21** | 24" #24CP4A Aluminized **\$59.99** | 27" #27EP4A Aluminized **\$74.31**

#630 Parts in COMPLETE SETS

TV WIRE & SOLDER KIT, for any Set.	\$.98
630-KIT, screws, nuts, rivets, washers, etc.	1.69
TERMINAL STRIP KIT, set of 30.	.69
VIDEO AND I.F. KIT, 19 items.	4.99
VARIABLE CONTROL KIT, 9 controls.	3.97
CARBON RESISTOR KIT, 107 resistors.	4.98
WIREWOUND RESISTOR KIT, 4 resistors.	1.76
BRACKET AND SHIELD KIT, 18 items.	6.44
ELECTROLYTIC CONDENSER KIT, 6 cond.	4.96
TUBULAR CONDENSER KIT, 38 condensers.	3.63
CERAMIC CONDENSER KIT, 28 condensers.	1.98
MICA CONDENSER KIT, 11 condensers.	.97
COMPLETE SOCKET KIT, 25 sockets.	1.57
COMPLETE SET OF TUBES, 29 tubes.	24.64

Brooks LIFE-SIZE TV INSTRUCTIONS for building any #630 TV Receiver. **\$1.25** Postpaid

HINTS FOR BETTER PERFORMANCE on your #630 TV receiver. **50c** Postpaid

Brooks CASCADE MANUAL, how to install Cascade Tuner in any make TV Set. **25c** Postpaid

PARTS For #630 TV SETS

PUNCHED CHASSIS PAN, cadmium plated.	\$3.96
COMPLETE SET OF KNOBS, incl. decals.	.99
POWER TRANSFORMER, 295ma.	201T6 9.16
VERTICAL OUTPUT TRANS.	204T2 2.24
VERTICAL BLOCKING TRANS.	208T2 .98
HORIZONTAL OUTPUT TRANS.	211T1 1.62
HORIZONTAL OUTPUT TRANS.	211T5 2.97
FOCUS COIL, 247 ohms.	202D1 1.64
FOCUS COIL, 470 ohms.	202D2 2.93
DEFLECTION YOKE, 60°	201D1 1.14
DEFLECTION YOKE, Cosine 70°	206D1 3.45
SOUND DISCRIMINATOR TRANS.	203K1 .94
1st PIX I.F. TRANSFORMER.	202K2 .88
2nd PIX I.F. TRANSFORMER.	202K3 .88
1st or 2nd SOUND I.F. TRANS.	201K1 .69
HORIZONTAL DISCRIM. TRANS.	208T8 .98
FILTER CHOKE, 62 ohms.	202K4 1.15
CATHODE TRAP COIL.	202K4 .88
WIDTH CONTROL COIL, keyed AGC.	.52
ION TRAP BEAM BENDER, single	203D1 .52
HV RECTIFIER, SOCKET ASSEMBLY, double	.98

H. V. FILTER CONDENSERS—(Cartwheels)

10kv	500 mmf	.10
20kv	500 mmf	.39
30kv	500 mmf	.97

100 ASSORTED TUBULAR CONDENSERS
All Are Standard Brands & Desirable Sizes **\$3.69**
\$15.00 Value Only

100— ASSORTED 1/2 WATT RESISTORS \$2.88

15 — Assf. Radio Electrolytic CONDENSERS \$3.49

15 — Assorted TV Electrolytic CONDENSERS \$4.97

100— ASSORTED MICA CONDENSERS \$3.72

100— ASSORTED CERAMIC CONDENSERS \$3.72

100— ASSORTED 1 WATT RESISTORS \$4.62

100— ASSORTED SOCKETS \$2.79
Octal, Loctal & Miniature

100— ASSORTED KNOBS \$2.84
SCREW & PUSH-ON

10 — VOLUME CONTROLS \$2.63
ASSORTED, WITH SWITCH 1/4, 1/2, 1, 2 meg. and others

BROOKS RADIO & TV CORP., 84 Vesey St., Dept. A, New York 7, N.Y. TELEPHONE CORland 7-2395

New PORTABLE DOUBLE-DUTY Money-Maker



Size only 11" x 7 1/2" x 5"

Spots the Trouble and Quickly Corrects it—without removing tube from set!

Now it's easy to save thousands of weak and inoperative TV picture tubes. As much as 80% of the troubles which arise in picture tubes may easily be repaired with the CRT. This amazing portable instrument creates new profitable picture tube repair business. Saves servicing time, speeds work. Assures more satisfied customers. Eliminates tube transportation. Saves money on trade-in reconditioning. And at such low cost, the CRT quickly pays for itself—and continues to make big profits for TV service-dealers.

See Your Distributor, or
Write for Bulletin No. 102E

TESTS and REPAIRS TV PICTURE TUBES

Amazing **\$54⁹⁵**
Low Price NET

No extra accessories necessary



DOES ALL THIS

TESTS FOR Emission, Inter-Element Shorts, Leakage, Open Circuits, Grid Cut-Off, Gas Content, Probable Useful Life

RESTORES Emission and Brightness

REMOVES Shorts

REPAIRS Open Circuits

Less than one foot long.
Weights only five pounds.

B&K MFG. CO. 3731 N. Southport • Chicago 13, Illinois

- RECORD CHANGER
- WIRE RECORDER
- TAPE RECORDER

MECHANISM PARTS

(Post War Only)

Over 50,000 parts IN STOCK

Send us your broken parts and machine model number (if possible), and we will quote you on the cost of replacements. If we can't quote, we'll return your parts promptly.

**RECORD CHANGERS—
WIRE & TAPE PARTS COMPANY**
97 Reade Street, New York 13, N. Y.
Dept. E

OSCIL-O-PEN

Extremely convenient test oscillator for all radio servicing; alignment • Small as a pen • Self powered. • Range from 700 cycles audio to over 600 megacycles u.h.f. • Output from zero to 125 v. • Low in cost • Used by Signal Corps. • Write for information.

GENERAL TEST EQUIPMENT
38 Argyle Ave. Buffalo 9, N. Y.

ENJOY 3 COLOR TELEVISION FILTER SCREEN NOW

Changes dull eye-straining black and white pictures into beautiful color tones. Seconds to attach. No tools used. Helps eliminate glare and snow in fringe areas. Order direct. Send \$1 for screen size up to 16". \$1.25 size 17". \$1.50 size 20". \$2 size 21". \$2.50 size 24". \$3 size 27". We pay postage except on C.O.D. orders. Satisfaction guaranteed. Inquiries from dealers also welcomed.

Zingo Products, Johnstown 13, New York

GUILD MEETS THE D.A.

Officers of the Radio and Television Guild of Long Island met with the local District Attorney, Frank Gulotta, to discuss ways and means of curbing unethical and fraudulent practices in TV servicing. The meeting was the result of newspaper reports that the D. A. was requesting "laws to curb TV gypps."

Mr. Gulotta was especially interested in the Guild's grievance committee, set up to receive complaints against service technicians and to act on them. After the discussion, he agreed to refer to the Guild complaints received at his office, whether the complaint is against a Guild member or not. Results of the grievance committee's investigation are to be turned over to the District Attorney's office.

The Guild members pointed out that most complaints have resulted from misunderstanding between customer and technician and that the best way to improve customer relations is to clear up these situations before they get out of hand.

PHILADELPHIA UNITES

Delegates from the Northeast T.S.D.A., Television Contractors Association and Television Service Dealers Association of Philadelphia met February 10 to iron out final points of amalgamation as authorized by their membership. Upon reaching satisfactory agreement the delegates voted for the formation of a consolidated group to be known as the Electronic Service Association. This, it was stated, would bring all the Philadelphia service dealer groups under one banner, making it the largest service dealers' association.

Temporary officers were appointed to hold office till an official election is held by the entire membership. The appointed officers are Fred Weissman, chairman; Albert Haas, vice chairman and treasurer; Wm. Weil, Jr., secretary, and Dave Krantz, corresponding secretary and chairman of publicity.

Messrs. Richard Devaney and Samuel Brenner of the Philadelphia Radio Service Men's Association were present at the meeting and reported that their board of directors had voted in favor of consolidating with the newly formed E.S.A. and were now awaiting the approval of the membership. The P.R.S.M.A. is one of the largest and oldest technicians' organizations.

A committee under the chairmanship of Dave Krantz will study the individual constitutions and by-laws of each of the uniting groups for the purpose of preparing a set of operating rules for the E.S.A.

RETMA TRAINING COURSES

The Radio-Electronic-Television Manufacturers Association has issued a booklet, *Industry Advisory Groups*, explaining in detail the organization of committees to coordinate local interests and to establish in their localities courses based on the methods, curricula,

TERADO



Trav-Electric CONVERTERS

provide
House Current

Anywhere

—from battery in car, truck, boat. At the beach—picnic grounds—at cabin—on trips—anywhere! Easy! No installation! Just plug Trav-Electric into cigar lighter on dash.

Trav-Electric Operates:

- Tape Recorders
- Electric Shavers
- Radios
- Soldering Irons
- Dictating Machines
- Small Electric Drills
- Portable Phonographs
- Etc. etc. etc.

6 Models 10 to 100 Watts

—a size for every need.

"Midget"

Model 6-11160
10-15 Watts

About as small as a pack of cigarettes.

\$11.95 LIST



PORTABLE PHONOGRAPH



LECTRIC SHAV



ELECTRIC SHAV

"JUNIOR"

Model 6-1110
115 Cycle
30-40 Watts
\$12.95 LIST

"SENIOR"

Model 6-11160
Size 2 1/2" x 2 1/2" x 4 1/2"
35-40 Watts
\$15.95 LIST

"MASTER"

Model 6-51160
40-50 Watts
Size 4" x 5" x 6"
\$27.50 LIST

"SUPER"

Model 6-71160
(Shown at top of ad)
60-75 Watts
Size 4" x 5" x 6"
\$37.95 LIST

—and now, the "CHIEF"
NEW—JUST OUT—Model 6-81160—75-100 Watts—automatic on-off switch—
\$49.95 LIST

See your Electronic, Hardware,
or Automotive Jobber or Dealer

Terado Company

Designers and Mfrs. of Electronic Equipment
1057 Raymond Ave., ST. PAUL 14, MINN.

In Canada Write: Atlas Radio Corp., Ltd.
560 King St. West, Toronto 28, Ont.
Export Sales Division: Scheel International, Inc.
4237 N. Lincoln Ave., Chicago 18, Ill. U.S.A.
Cable Address—Harsheel

TECHNICIANS' NEWS (Continued)

manuals of instruction, special equipment for training and teaching methods developed under the supervision of the RETMA Service Committee.

The 14-page booklet is available to all service groups, educators and other interested parties upon request from RETMA headquarters, 777 14 St. N. W., Washington, D. C.

LONG BEACH ASKS LICENSE

The Long Beach, Calif., Radio Technicians Association has proposed to its City Council that an ordinance be established requiring that all radio-TV technicians be licensed. RTA proposes that a board of examiners be set up to pass on the fitness of service technicians before issuing them licenses permitting them to service radio and television equipment in Long Beach.

MORE TV ANTENNA USES

An item in this column last month told how a Nebraska family used their TV antenna mast as a fire escape. Harry Josephs, a Pennsylvania service technician, sends us the following:

One of our customers has a duck blind at a lake near his home. When rival hunters claimed last fall that their blinds had hot and cold running water and all the comforts of home, this customer hauled us all the way out to his blind and had us stick up a complete antenna system—without a TV set. "It's just a gag," he explained, "and if it scares the ducks, we'll pay you to take it down." He and his friends spread the word to other hunters that their video set is battery-powered and they watch TV when the ducks aren't flying! When rival hunters get too curious and come over to see for themselves, the "missing" set is always "in Josephs' shop getting repaired."

INDISCRIMINATE SELLING

The following resolution was released by the Associated Radio and Television Servicemen, Ill., a Chicago association:

"The individual members of ARTS, Illinois, independent radio and television service shop owners and dealers, have long known of and suffered from the practice of indiscriminate selling at wholesale prices to any and all of the consuming public by the radio and electronics parts jobbers and wholesalers.

"They are also aware of the indiscriminate distribution by these same jobbers and wholesalers of catalogs containing wholesale prices of electronic parts and supplies.

"Therefore the members of ARTS, Illinois, express themselves in opposition to these unfair trade practices.

"Further, the members of ARTS, Illinois, request their officers and executive committee to make known the feeling and the position of the members regarding this sales policy." END

EDLIE for TOP VALUES

Newest & Best "Fix-It-Yourself" Aid Larrel's E-Z TV REPAIR GUIDE

The Only **FIX-IT-YOURSELF** Guide
Made expressly for **YOUR TV SET!**

Now you can save costly TV repairs with this new, simplified method which includes all necessary data for just **YOUR** set. No confusing, unimportant information applicable to hundreds of other makes. Simplifies detection of faulty tubes in your TV receiver quickly, accurately.

It's a terrific idea—it's a terrific guide! Order today and have your set back in only perfect condition at once. Be sure to send us make and model of your TV when **50¢** orderings.

New CODE KEYS, J-38

Brand new! Signal Corp. U.S. Army, black bakelite base, 3" x 4 3/4", brass bumper, strip, & binding posts. Circuit closing switch. Completely adjustable. **79¢**
Special

Save! HIGH PASS FILTER

Input impedance: 600 ohms; output impedance 5,000 ohms. 300 cycles cut off frequency at 3,500 cycles attenuates at 2 db.; at 120 cycles attenuates at 20 db.; at 60 cycles attenuates at 45 db. 2" x 3 1/2" x 2". Original cost: \$2. **\$1.35**
Reduced to

Save! LOW PASS FILTER

At 3,500 cy. attenuates at less than 0.2 db.; at 8,000 cy. attenuates at greater than 60.0 db.; at 6,000 cy. attenuates at greater than 50.0 db. Input impedance: 5,000 ohms. Original cost: \$15.
Reduced to **\$1.45**

SAVINGS ON KITS

INSULATED RESISTOR KIT

100 INSULATED RESISTORS. RMA code marked all 1/2 watt varying in ohmage from 1 ohm to 10 megohms and tolerance of 5%, 10% & 20% of standard makes. RMA color code chart included FREE. Special! **95¢**

DeLuxe Insulated Resistor Kit

Includes: 15-2 watt, 35-1 watt and 50-1/2 watt values up to 20 megs. Housed in a transparent plastic box, 4 3/8" x 2 3/4" x 1". 4-compartments. Reduced to **\$2.25**

FLEXIBLE W. W. PIGTAIL RESISTOR KIT

100 Resistors of asst. ohmages and wattage. **\$1.65**

CANDOHM W. W. metal clad

25 Resistors of asst. ohmages and wattage. **95¢**

WIRE WOUND RESISTOR KIT

25 Wire Wound Resistors up to 50-1/2 ohms. 5, 10, 20, 30, 50, and 100 watt resistors **\$1.95**

PRECISION CARBOFILM RESISTOR KIT

1% tolerance in ohmages from 5 to 2.2 megohm. \$25 value **\$2.45**

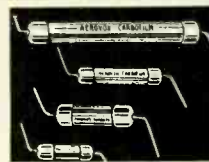

Terrific Buy! PRECISION WIRE WOUND RESISTOR KIT



20 Precision W.W. resistors, 1% tolerance, 20 different ohmages ranging up to 1/2 megohm, 1/2 & 1 watt. \$25 value **\$2.45**

Disc Condenser Kit

50 Disc condensers—.001, .0015, 2X0015, 2X004, 0047, .005, .01, 2X01, & 0000 10/2KV mfd. of equal amounts. **\$1.95**
Now!

CERAMIC CONDENSER KIT

50 Tubular ceramic (solid and hollow) ranging in capacity from 1 to 4700 mfd. Special! **\$1.75**

Write today for FREE Catalog. All mdse. shipped F.O.B. New York City, prices subject to change without notice. Include 20% deposit with C.O.D.'s.

EDLIE ELECTRONICS

154 Greenwich St. New York 6, N.Y.
DI. 9-3143



Measures 6 1/4" x 9 1/2" x 4 1/2"

Superior's new
Model 670-A

SUPER METER

A COMBINATION VOLT-OHM MILLIAMMETER PLUS
CAPACITY REACTANCE INDUCTANCE AND DECIBEL MEASUREMENTS

SPECIFICATIONS:

D.C. VOLTS: 0 to 7.5/15/75/150/750/1,500/7,500 Volts
A.C. VOLTS: 0 to 15/30/150/300/1,500/3,000 Volts
OUTPUT VOLTS: 0 to 15/30/150/300/1,500/3,000 Volts
D.C. CURRENT: 0 to 1.5/15/150 Ma. 0 to 1.5/15 Amperes
RESISTANCE: 0 to 1,000/100,000 Ohms 0 to 10 Megohms
CAPACITY: .001 to 1 Mfd. 1 to 50 Mfd. (Good-Bad scale for checking quality of electrolytic condensers.)
REACTANCE: 50 to 2,500 Ohms 2,500 Ohms to 2.5 Megohms
INDUCTANCE: .15 to 7 Henrys 7 to 7,000 Henrys
DECIBELS: -6 to +18 +14 to +38 +34 to +58

ADDED FEATURE:

Built-in ISOLATION TRANSFORMER
reduces possibility of burning out
meter through misuse.

The Model 670-A comes housed, in a rugged crackle-finished steel cabinet complete with test leads and operating instructions.

\$2840
NET



Superior's new
Model TV-11

TUBE TESTER

SPECIFICATIONS:

- ★ Tests all tubes including 4, 5, 6, 7, Octal, Lock-in, Peanut, Bantam, Hearing Aid, Thyatron Miniatures, Sub-miniatures, Novals, Sub-minars, Proximity fuse types, etc.
- ★ Uses the new self-cleaning Lever Action Switches for individual element testing. Because all elements are numbered according to pin-number in the RMA base numbering system, the user can instantly identify which element is under test. Tubes having tapped filaments and tubes with filaments terminating in more than one pin are truly tested with the Model TV-11 as any of the pins may be placed in the neutral position when necessary.
- ★ The Model TV-11 does not use any combination type sockets. Instead individual sockets are used for each type of tube. Thus it is impossible

to damage a tube by inserting it in the wrong socket.

- ★ Free-moving built-in roll chart provides complete data for all tubes.
- ★ Newly designed Line Voltage Control compensates for variation of any Line Voltage between 105 Volts and 130 Volts.
- ★ NOISE TEST: Phono-jack on front panel for plugging in either phones or external amplifier will detect microphonic tubes or noise due to faulty elements and loose internal connections.

The model TV-11 operates on 105-130 Volt 60 Cycles A.C. Comes housed in a beautiful hand-rubbed oak cabinet complete with portable cover

EXTRA SERVICE — The Model TV-11 may be used as an extremely sensitive Condenser Leakage Checker. A relaxation type oscillator incorporated in this model will detect leakages even when the frequency is one per minute.

\$4750
NET



SUPERIOR'S NEW MODEL TV-40

C.R.T. TUBE TESTER

A complete picture tube tester
★ for little more than the price
of a "make-shift" adapter!!

★ Tests all magnetically deflected
tubes . . . in the set . . . out
of the set . . . in the carton!!

The Model TV-40 is absolutely complete! Self-contained, including built-in power supply, it tests picture tubes in the only practical way to efficiently test all tubes: that is, by the use of a separate instrument which is designed exclusively to test the ever increasing number of picture tubes!

EASY TO USE:

Simply insert line cord into any 110 volt A.C. outlet, then attach tester socket to tube base (Don't Trap Need Not Be on Tube). Throw switch up for quality test . . . read direct on Good-Bad scale. Throw switch down for all leakage tests.

SPECIFICATIONS:

- Tests ALL magnetically deflected picture tubes from 7 inch to 30 inch types.
- Tests for quality by the well established emission method. All readings on "Good-Bad" scale.
- Tests for inter-element shorts and leakages up to 5 megohms.
- Tests for open elements.

Model TV-40 C.R.T. Tube Tester comes absolutely complete—nothing else to buy. Housed in round cornered, molded bakelite case. Only.....

\$1585
NET

**SHIPPED ON APPROVAL
NO MONEY WITH ORDER — NO C.O.D.**

Try any of the above instruments for 10 days before you buy. If completely satisfied then send down payment and pay balance as indicated on coupon. No Interest or Finance Charges Added! If not completely satisfied return unit to us, no explanation necessary.

MOSS ELECTRONIC DISTRIBUTING CO., INC.
Dept. D-114, 3849 Tenth Ave., New York 34, N.Y.

Please send me the units checked. I agree to pay down payment within 10 days and to pay the monthly balance as shown. It is understood there will be no finance, interest or any other charges, provided I send my monthly payments when due. It is further understood that should I fail to make payment when due, the full unpaid balance shall become immediately due and payable.

Model 670-A.....Total Price \$28.40
\$7.40 within 10 days. Balance \$3.50
monthly for 6 months. Model TV-11.....Total Price \$47.50
\$11.50 within 10 days. Balance \$6.00
monthly for 6 months. Model TV-40.....Total Price \$15.85
\$3.85 within 10 days. Balance \$4.00
monthly for 3 months.

Name

Address

City..... Zone..... State.....

The Model
TV-50

GENOMETER

A versatile all-inclusive GENERATOR which provides ALL the outputs for service

A. M. Radio F. M. Radio Amplifiers Black and White TV Color TV



7 Signal Generators in One!

- ✓ R. F. Signal Generator for A.M.
- ✓ R. F. Signal Generator for F.M.
- ✓ Audio Frequency Generator
- ✓ Bar Generator
- ✓ Cross Hatch Generator
- ✓ Color Dot Pattern Generator
- ✓ Marker Generator

SPECIFICATIONS:

R. F. SIGNAL GENERATOR:

The Model TV-50 Genometer provides complete coverage for A.M. and F.M. alignment. Generates Radio Frequencies from 100 Kilocycles to 60 Megacycles on fundamentals and from 60 Megacycles to 180 Megacycles on powerful harmonics. Accuracy and stability are assured by use of permeability trimmed Hi-Q coils. R.F. is available separately, modulated by the fixed 400 cycle sine-wave audio or modulated by the variable 300 cycle to 20,000 cycle variable audio. Provision has also been made for injection of any external modulating source.

VARIABLE AUDIO FREQUENCY GENERATOR:

In addition to a fixed 400 cycle sine-wave audio, the Model TV-50 Genometer provides a variable 300 cycle to 20,000 cycle peaked wave audio signal. This service is used for checking distortion in amplifiers, measuring amplifier gain, trouble shooting hearing aids, etc.

BAR GENERATOR:

This feature of the Model TV-50 Genometer will permit you to throw an actual Bar Pattern on any TV Receiver Screen. Pattern will consist of 4 to 16 horizontal bars or 7 to 20 vertical bars. A Bar Generator is acknowledged to provide the quickest and most efficient way of adjusting TV linearity controls. The Model TV-50 employs a recently improved Bar Generator circuit which assures stable never-shifting vertical and horizontal bars.

CROSS HATCH GENERATOR:

The Model TV-50 Genometer will project a cross-hatch pattern on any TV picture tube. The pattern will consist of non-shifting, horizontal and vertical lines interlaced to provide a stable cross-hatch effect. This service is used primarily for correct ion trap positioning and for adjustment of linearity.

DOT PATTERN GENERATOR (For Color TV)

Although you will be able to use most of your regular standard equipment for servicing Color TV, the one addition which is a "must" is a Dot Pattern Generator. The Dot Pattern projected on any color TV Receiver tube by the Model TV-50 will enable you to adjust for proper color convergence. When all controls and circuits are in proper alignment, the resulting pattern will consist of a sharp white dot pattern on a black background. One or more circuit or control deviations will result in a dot pattern out of convergence, with the blue, red and green dots in overlapping dot patterns.

MARKER GENERATOR:

The Model TV-50 includes all the most frequently needed marker points. Because of the ever-changing and ever-increasing number of such points required, we decided against using crystal holders. We instead adjust each marker point against precise laboratory standards. The following markers are provided: 189 Kc., 262.5 Kc., 456 Kc., 600 Kc., 1000 Kc., 1400 Kc., 1600 Kc., 2000 Kc., 2500 Kc., 3579 Kc., 4.5 Mc., 5 Mc., 10.7 Mc. (3579 Kc. is the color burst frequency.)

The Model TV-50 comes absolutely complete with shielded leads and operating instructions. Only

\$47⁵⁰
NET

SHIPPED ON APPROVAL NO MONEY WITH ORDER — NO C.O.D.

Try it for 10 days before you buy. If completely satisfied then send \$11.50 and pay balance at rate of \$6.00 per month for 6 months. **No Interest or Finance Charges Added!** If not completely satisfied return unit to us, no explanation necessary.

MOSS ELECTRONIC DISTRIBUTING CO., INC.
Dept. D-114, 3849 Tenth Ave., New York 34, N.Y.

Please rush one Model TV-50. I agree to pay \$11.50 within 10 days and to pay \$6.00 per month thereafter. It is understood there will be no finance, interest or any other charges, provided I send my monthly payments when due. It is further understood that should I fail to make payment when due, the full unpaid balance shall become immediately due and payable.

Name

Address

City..... Zone..... State.....

AMPLIFIER

20 Watts Ultra-Linear
6L6 push-pull output, 40 watts peak

Push-Button Phono Equalizer
For LP, RIAA, LON and EUR curves

Z729 Preamplifier Tube
Phono hum and noise below 1.5 μ V.

Speaker Damping Factor Selector
Range includes -2 and +2

"Center-Set" Loudness Control
New contours extend useful ranges

Tape Recording Jack
Cathode follower: switched for playback

"Pivoting" Tone Controls
Calibrated: accurate flat setting

Rumble Filter Switch

Phono Scratch Filter Switch

Five Inputs and many other professional features

Send for detailed descriptive literature or see your local high fidelity distributor.

Model S1000B \$ 99.50 net
Black and Gold finish

Model S1000C \$104.50 net
Gold-tooled Cordovan Leatherette



Dept. 4-E, 2802 W. Cullom Ave., Chicago 18, Ill.

Technotes



MUNTZ MODEL 169 TV SET

This set came in with the picture screen-grid circuit of the 6BG6-G. The 6BG6-G horizontal oscillator and output tube was O.K. The trouble was traced to a leaky 0.2- μ f capacitor in the

trouble cleared up when this defective capacitor was replaced with a good one having the same capacitance.—*Carl Hennig*

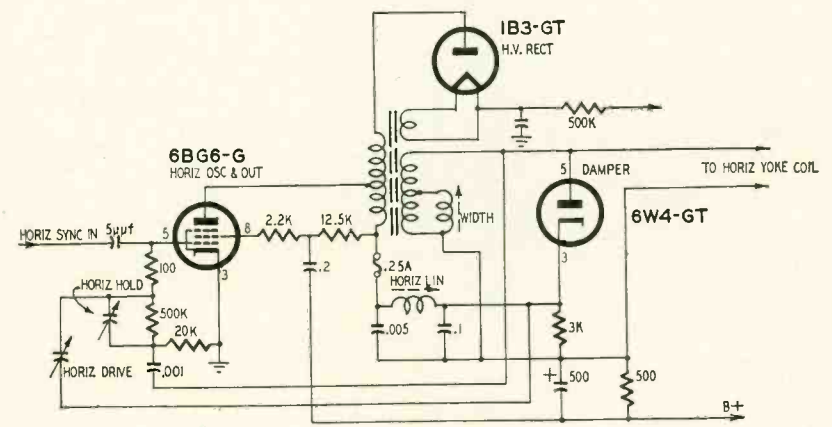

6W4-GT BURNOUTS?

Like H. A. Highstone (Tube Failures, page 186, January, 1954), I find burned out 6W4-GT's extremely rare. I've found only one genuine burnout among the many 6W4's I've repaired (I crimp the heater pins with diagonal cutters).
The tube base is a poor heat radiator

so the solder softens in the heater pins and the lead opens. One failure cured me of attempting to resolder the pins. I now use the diagonal cutters to crimp the heater pins on all 6W4's suspected of cold-soldered joints and thus avoid a great deal of trouble.—*Walter T. Stevenson*

DUMONT RA-103-D

When the volume control was advanced beyond a certain critical point, a steady howl came from the speaker and black sound bars appeared on the screen. This was the tip-off that the howl originated at some point common to both picture and audio circuits. Tapping one of the 5U4G's gave an indication of the fault; replacing this

defective tube cleared up the trouble immediately.
Upon examination, the filament of the tube showed flaking, which had apparently so weakened the tube that it vibrated with increased volume. On the other hand, there is the possibility that the vibration caused the flaking.—*H. L. Matsinger*

B PLUS SHORT IN RCA 6T54

Low sound volume and poor picture quality—several of these models had the same difficulty. When the tuner operating voltages were checked, only 40 volts was read at the 6AG5 r.f. amplifier test point. Normally there should be 115 volts here. Somehow or other this test-point terminal shorts to the tuner chassis, resulting in little or no B plus voltage at the 6AG5. The pot-

metal construction of the test-point terminal and the way it is mounted in the tuner chassis prevent its immediate replacement. To restore the receiver to normal operation I usually drill a 3/16-inch or smaller hole through the test-point terminal into the tuner and insert a piece of heavy wire enclosed in some spaghetti.—*Wilbur J. Hantz*

MOTOROLA VT 71M-A

A heater-to-cathode short in the third i.f. tube will show up as audio hum and the picture will have the usual black bars separated by a wide, rough white line, indicative of a.c. hum. An electrolytic capacitor will apparently

have gone, but there will be no hum in the speaker when the volume control is turned two-thirds of the way down. Also the raster will be clean if you ground the control grid of the video output tube.—*B. W. Welz* END

The Gernsback Library

An up-to-the minute library of low-cost technical books which gives you complete and valuable information on every phase of practical electronics in a readable and understandable way.

BOOKS ON TV-RADIO-AUDIO SERVICING



The Oscilloscope—
No. 52. 192 Pages.
\$2.25

Gives details on how to use the scope for more efficient TV, radio, or audio servicing. Will open many new scope applications to the practicing service technician.



TV Repair Techniques—No. 50.
\$1.50

Top technician-writers give you the benefit of their experience in finding and correcting tricky TV servicing problems. Will save you hours of servicing time.



Radio & TV Test Instruments—No. 49.
\$1.50

How to build the instruments required for modern TV-radio-audio servicing, plus chapters on constructing a bench and carrying case. Each instrument tested by the authors.



Television Techniques—No. 46.
\$1.50

Symptoms, causes, and cures of over 600 TV troubles which occur in scores of sets made by leading manufacturers. Will help cut trouble-shooting time to the bone in TV servicing.

HIGH FIDELITY

High-Fidelity — Design, Construction, Measurements—No. 48. **\$1.50**

New 3-way approach to top hi-fi performance.

High-Fidelity Techniques—No. 42. **\$1.00**
James R. Langham's humorous, common-sense guide to high fidelity.



FUNDAMENTALS

Basic Radio Course—No. 44 Cloth cover **\$2.25**

John T. Frye teaches you theory from Ohm's Law to advanced techniques, in an entertaining way.

Radio Tube Fundamentals—No. 45. **\$1.00**

Theory of tubes from the technician's viewpoint.



RADIO CONTROL

Radio-Control Handbook—No. 53. **\$2.25**

R/C expert, Howard G. McEntee, W2SI, tells you how to build R/C systems and the mechanical components to control model planes, boats, etc.

Model Control By Radio
No. 43. 112 Pages. **\$1.00**

A wonderful companion volume for book 53. For both beginner and expert. Covers theory and practical construction.



TRANSISTORS

Transistors — Theory and Practice—No. 51.
\$2.00

Rufus P. Turner writes about transistors for the practical man, in a down-to-earth way. Transistor applications in well known circuits. First complete guide to commercial transistors.



See your distributor—or mail this coupon

GERNSBACK PUBLICATIONS, INC., Dept. 45
25 West Broadway
New York 7, N.Y.

Enclosed is my remittance of \$.....
Please send me the following books postpaid.

39 41 42 43 44 45 46
 47 48 49 50 51 52 53

Name

(Please print clearly)

Street

City Zone State

MISCELLANEOUS

Radio & TV Hints—No. 47. **\$1.00**
300 hints, gimmicks and short cuts on TV, radio, audio.

Public-Address Guide—No. 41. **75c**
How to make extra money in PA work.

Practical Disc Recording—No. 39. **75c**
Theory and techniques.

HERSHEL'S "KIT" SPECIALS

ALL-PURPOSE FIL. TRANSFORMER

For Model Trains, Welding, Transmitters, etc.
Pri. 117 v. 60 cyc. sec.
6.4 v.12A
6.4 v.10A
5 v.3A
5 v.3A
2.5 v.1.75A

\$4.95

MYSTERY PACKAGE ELECTRONIC PARTS

The Surprise of Your Life
25 pounds of BRAND NEW USABLE GOVT SURPLUS
Ideal gift for the ham, etc.
Worth \$50.
Our Price

\$4.95

KIT 1, HARDWARE

Over 1,000 pieces. 2 1/2 lbs. of assorted RADIO & TV HARDWARE.

\$1.49

KIT 5, RESISTORS

100 ASSORTED TYPES. Range from 1 ohm to 15 meg. 1/2 to 5 watts.

\$1.98

KIT 2, CERAMICONS

100 ASSORTED. Range from .75 mmfd. to 6,000 mmfd.

\$3.50

KIT 6, R.F. CHOKES

25 ASSORTED. Range from .5 mh. to 25 mh.

\$1.95

KIT 3, Volume Controls

25 ASSORTED. Range from 2 ohm to 3 meg. Some with switch.

\$4.75

KIT 7, TOGGLE & SLIDE SWITCHES

25 ASSORTED. Range from 4 SPST, etc.

\$4.95

Kit 4, Rotary Switches

25 ASSORTED TYPES. Real Buy at only

\$4.75

KIT 8, PAPER & CAN CONDENSERS

25 ASSORTED. Range from 4 mfd. 150 v. to 80 mfd. 450 v.

\$3.50

FIND YOUR KIT PARTS HERE FOR POPULAR ELECTRONICS KITS

TRANSFORMER—Pri. 110 V. 60 Cy. Sec. 6.3 V. 1 Amp. 95c
TRANSFORMER—Pri. 110 V. 60 Cy. Sec. 400 VCT. 6.3 V. 1 Amp. 5 V. 2 Amp. 20 Ma. \$1.49
SCOPE TRANSFORMER—Pri. 110 V. 60 Cy. Sec. 4000 V. 10 Ma. \$2.95
TRANSFORMER—Pri. 110 V. 60 Cy. Sec. 600 VCT. 6.3 V. 3 Amp. 5 V. 2 Amp. 70 Ma. \$2.45
RELAY D.P.D.T.—110 VAC. 8 Amp. contacts \$1.69
RELAY D.P.D.T.—3 VDC. 11 ohm coil cont. 1.5 Amp. 110 V. Gold Plated 95c
KEY—J38 Telegraph key 95c
LIP MIKE—With Head band cord and switch \$1.29
CHOKE—2.5 Mh. 125 Ma. 35c
CHOKE—1.5 Mh. 100 Ma. 15c
COIL—Plug in type 4, 5, 6, Prong Type 29c
OUTPUT TRANSFORMER—6V6 to 3.2 Voice Coil 39c
OUTPUT TRANSFORMER—P.P. 6V6 to 3.2 Voice Coil 59c
OUTPUT TRANSFORMER—50 L6 to 3.2 Voice Coil 35c
CHOKE—A.C.-D.C. Type. 8 H. 80 Ma. 49c
COIL—Ignition Type. Pri. 3 V. Sec. 15,000 VDC. Ideal for Photo Flash Triggering \$1.29
GLOW-LITE—2 1/2 Watt Argon Lite 110 VAC. 29c
MOTOR—From Gun Camera 24 VDC. Will Run on 110 VAC. 95c
CABINET—RCA Speaker Cabinet. Plastic for 8 inch Round Speaker \$1.95
RHEOSTAT—30 ohm 50 Watt 95c

HI GAIN DYNAMIC MIKE KIT

Uses UTC. Transformer and Western Electric Mike. Ideal for Hams, PA. CAP, Recording, Mobile Equip.
—50 DB/80-7500 CPS. **\$1.95**
Diagram Furnished

Terms: Cash with order or 25% DOWN—Balance will be shipped C.O.D.

ALL ITEMS SHIPPED F.O.B. DETROIT

HERSHEL RADIO CO.

5245 Grand River, Detroit 8, Mich.

Here's how to GET MORE WORK OUT OF YOUR Oscilloscope!

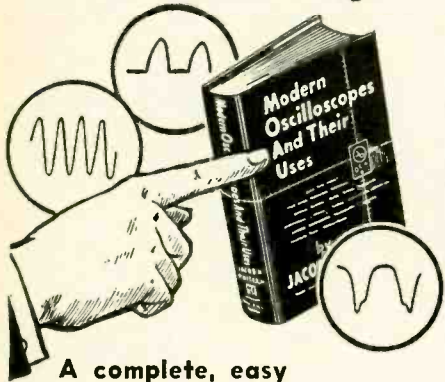

A complete, easy guide to the handiest most profitable service instrument of all
MODERN OSCILLOSCOPES AND THEIR USES

By Jacob H. Ruiter, Jr.

of Allen B. Du Mont Laboratories, Inc.
326 pages, 370 illustrations. Price \$6.

Oscilloscopes are gold mines for servicemen who learn to use them fast, fully and accurately on all types of work—and here at last is a book that really shows you how.

In clear, easily understood terms, it teaches you when, where and exactly how to use the oscilloscope... how to interpret patterns... how to use your 'scope to handle tough jobs easier, faster and better.

It contains no involved mathematics—no complicated discussions. Instead it gets right down to "brass tacks" in explaining how oscilloscopes operate. Then you learn exactly how to use them in lab work and on all types of AM, FM and television service—from locating troubles to handling tough realignment jobs.

Each operation is clearly explained step by step. You learn to determine just where and how to use the scope on a specific job; how to make connections and adjust the circuit components; how to set the controls; and HOW TO ANALYZE OSCILLOSCOPE PATTERNS fast and accurately. 370 illustrations including dozens of pattern photos make things doubly clear.



No other type of specific service training can mean so much to you in boosting your efficiency and earning power! Send coupon NOW for 10-day FREE examination!

'SCOPE EXPERTS get better jobs... bigger pay!

PRACTICE 10-DAYS FREE!

Dept. RE-45, Rinehart & Co., Inc.
232 Madison Ave., New York 16, N. Y.

Send MODERN OSCILLOSCOPES AND THEIR USES for 10-Day FREE EXAMINATION. If book is satisfactory, I will then send you \$6.00 plus postage promptly in full payment. If not, I will return book postpaid in good condition and owe you nothing.

NAME.....

ADDRESS.....

CITY, ZONE, STATE.....

OUTSIDE U.S.A. \$6.50, cash only. Money back if you return book within 10 days.

radio-electronic Circuits

1-TUBE FM TUNER

A well-designed FM receiver should have a low-noise tuner with an r.f. stage to minimize oscillator radiation. Designers of high-quality tuners and receivers will frequently use two tubes in the front end while 3-tube circuits are found in some equipment. The r.f. amplifier is usually a pentode such as

cathode triode r.f. amplifiers. Maximum gain is seldom required from an amplifier in a circuit such as this—its principal function is to isolate the antenna from the oscillator—so input coils L1-L2 can be adjusted for minimum noise rather than maximum voltage transfer. Use a noise generator

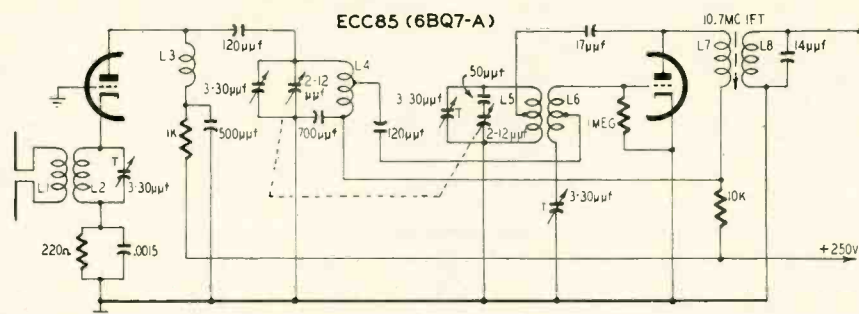

the 6BJ6.

The diagram shows the circuit of a 1-tube FM tuner that appeared in the application notes on the Mullard ECC85—a British twin triode similar to the 6BQ7 and other tubes used in cascade and low-noise circuits. Its characteristics being similar to the 6BQ7-A, it is possible that the latter can be substituted without modifying the circuit.

In this circuit, one triode is a grounded-grid r.f. amplifier. This simplifies the circuit by eliminating the neutralization required with grounded-

to obtain optimum adjustment.

The second triode is a self-oscillating mixer. R.f. voltage is tapped off L4 and fed to the null point on oscillator coil L6 to minimize oscillator radiation and noise. The oscillator circuit is plate-tuned with L5 coupled to the plate through a 17- μ f capacitor. This capacitor also tunes the plate winding of the 10.7-mc i.f. transformer. The grid-plate capacitance of the mixer triode may reduce amplification so some i.f. voltage is tapped off the plate circuit and fed back into the grid circuit at the grounded end of L4.

PREAMP MIXER

Because I use my Williamson-type amplifier for occasional PA jobs, I added a built-in preamplifier and mixer for microphones and phonograph inputs. The diagram shows the preamp mixer and the input stage of the Williamson amplifier. Mixing takes place in the grid circuit of the 6J5 phono pre-

amplifier. The 470,000-ohm series resistors in the grid leads prevent interaction between the gain controls. The 6SJ7 delivers enough gain for most high-impedance microphones. Low-impedance microphones of 50 to 600 ohms are used with mike-to-high-impedance adaptors.—Pedro A. Loorhuis

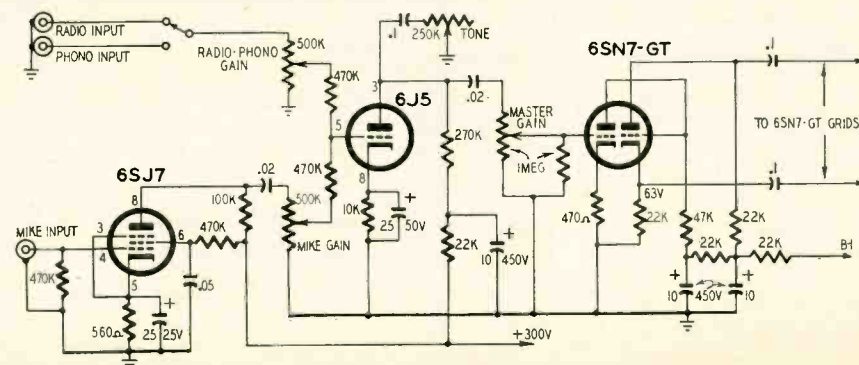

OPPORTUNITY ADLETS

Rates—45c per word (including name, address and initials). Minimum ad 10 words. Cash must accompany all ads except those placed by accredited agencies. Discount, 10% for 12 consecutive issues. Misleading or objectionable ads not accepted. Copy for June issue must reach us before April 15, 1955.

Radio-Electronics
25 W. Broadway, New York 7, N. Y.

REPAIRS ON ALL MAKES OF HIGH-FIDELITY SPEAKERS. Amprite Speaker Service, 70 Vesey St., New York 7, N. Y.

FIFTY ASSORTED NEW resistors—\$1.00. Test equipment repaired. Free Lists. Bigelow Electronics, Pioneer Road, Beulah, Michigan.

"Buy Surplus Radio. Electronic Equipment direct from Government. List \$1.00. Box 169AK, East Htrd 8, Conn."

SPEAKER RECONING: Guaranteed workmanship. C&M Recome Co., 255 Tioiga St., Trenton 9, N. J.

NEW, EXCITING RADIO and TV Items. Many. Increase pleasure. Save money. Free details. Write for literature. Postcard sufficient. Write Now: CAPCON, INC., 26 Willett Street, New York 2, N. Y.

TUBES—70% to 90% DISCOUNT. Government, manufacturers, jobbers, etc. surplus. Guaranteed 1 year. Free catalog on request. Cadillac Trading, Dept. AA, 231-07 Linden Blvd., Jamaica 11, N. Y.

DIAGRAMS FOR REPAIRING RADIOS \$1.00. Television \$2.00. Give Make, Model. Diagram Service, Box 672-RE, Hartford 1, Conn.

LETTER YOUR OWN UNIFORMS QUICKLY and Easily. No sewing. Shop name, phone, etc. Free sample information. Doc's, Box 523, Brownwood, Texas.

FIDELITY UNLIMITED—BUILT by service and quality. Authorized Distributors of the finest Hi-Fidelity Tuners—Speakers—Amplifiers—Turntables—etc. Full Line. Audio consultation service for "best buys". Shipments prepaid and insured. Top allowance for used equipment. Visit our showroom or write today answer via airmail. To our customers throughout the U.S. THANKS. Fidelity Unlimited, 63-03 39th Ave., Dept. RE, Woodside 77, N. Y.

TELEVISION JOBS—Names and addresses of companies to contact. \$1.00 Fitzgerald, Dept. A-23, 815 Countryside Drive, Wheaton, Illinois.

TUBES—TV, RADIO, TRANSMITTING, AND SPECIAL PURPOSE TYPES BOUGHT. SOLD AND EXCHANGED. Send details to B. N. Gensler W2LNI, 512 Broadway, N. Y. 12, N. Y.

ALL MAKES OF ELECTRICAL INSTRUMENTS AND TESTING equipment repaired. Write for free catalogue on new and used instruments at a savings. Hazelton Instrument Co., 128 Liberty Street, New York, N. Y.

WANTED: AN/APR-4, other "APR.". "TS-". "IE-". ARC-1, ARC-3, ART-13, BC-348, etc. Microwave Equipment. Everything Surplus. Special tubes, Tec Manuals, Lab Quality Equipment, Meters, Fast Action, Fair Treatment. Top Dollars! Littell, Fairhills Box 26, Dayton 9, Ohio.

MC'S SPEAKER RECONING. 2" to 4", \$1.25; 5", \$1.50; 6", \$1.75; 7", \$2.00; 8" to 9", \$2.25; 10" to 11" \$2.50; 12", \$3.00; 2" by 3", \$1.25; 4" by 6", \$1.75; 5" by 7", \$2.00; 6" by 9", \$2.25. Randall McDonald, 506 N. Ward, Beaton, Ill.

COMPLETELY NEW. AMAZING, inexpensive, printed-circuit, TV high-pass filter. Eliminates all annoying TV picture interference: ghosts, herring-bones, flutters, etc. Install in only 30 seconds with screwdriver. Has six coils and four condensers. Try five days. Money back guarantee. ONLY \$1. Postpaid. Mail cash, check or money order to: CAPCON, Inc., 26 Willett Street, New York 2, N. Y.

SPEAKER RECONING: 25 years experience. Michigan Speaker Reconing Service, 930 Metropolis, Marine City, Michigan.

WANTED—Pre-1920 wireless equipment, books, etc. WAGH 1010 Monte Drive, Santa Barbara, California.

ALUMINUM TUBING, Angle and Channel. Plain and Perforated Sheet. Willard Radcliff, Fostoria, Ohio.

Power Transformers Rebuilt: all makes, Victor R32—\$12.95. Red Arrow Radio, 924 Metropolis, Marine City, Michigan.

25-50% DISCOUNT, guaranteed. Factory Fresh LP records; 69c and up; pre-recorded tapes. Send 20c for catalogue. SOUTHWEST RECORDS, 4710 Caroline, Houston 4, Texas.

TELEVISIONS, WORKINGS, \$30 UP. W4APL, 1420 South Randolph, Arlington 4, Virginia.

WALKIE-TALKIE. BUILD a real wireless two-way portable radiophone for less than \$10.00. Plans 50c. Springfield Enterprises, Box 54-F4, Springfield Gardens 13, New York.

GEIGER COUNTER KIT. Assemble it yourself. All holes drilled ready for wiring. No special tools required. Complete with tubes, batteries, headset. Only \$17.50 postpaid. Stowers & Son, 804 Grand, Kansas City, Missouri.

FOR SALE—"URANIUM DETECTOR" Scintillator and Geiger Counter Diagram. Send \$1.00 to: Uranium, 13833 San Antonio, Norwalk, Calif.

TV FM ANTENNAS. ALL TYPES INCLUDING UHF. Mounts, accessories. Lowest prices. Wholesale Supply Co., Lunenburg 2, Mass.

CLOSE OUT SET MANUFACTURERS' INVENTORY

ALL RADIO AND TV TYPES

TUBES

EVERY TUBE GUARANTEED A FULL YEAR Individually Boxed
JOBBER! DISTRIBUTORS! We have a Wonderful Deal For You. Write—Wire—Phone!

0A2	5.87	1U4	.46	6AT6	.36	6N7	.95	7F7	.64	12SF5	.48	35Z3	.40	
0A3	VRR5	.97	1J5	.40	6AU6	.40	6Q7	.49	7F8	.80	12SF7GT	.68	35Z5GT	.59
0A4G	.60	1X2	.55	6AV6	.36	6S4	.39	7K7	.80	12SH7	.70	37	.35	
0B2	.74	2A3	.90	6AX4GT	.57	6S7G	.55	7L7	.77	12SJ7	.55	39-44	.35	
0B3	VRR90	.90	2A5	.49	6B7	.93	6SA7	.40	7M7	.57	12SN7GT	.49	42	.40
0C3	VRI05	.95	2A6	.49	6B8	.29	6SC7	.75	7Q7	.57	12SN7GT	.50	43	.53
0D3	VRI50	.85	2A7	.60	6BR8	.29	6SC7	.75	7Q7	.57	12SN7GT	.53	45Z3	.40
024	.59	2B7	.62	6BA5	.38	6SD7GT	.38	7R7	.59	12SN7GT	.50	43	.53	
1A4P	.40	2K2	.42	6B7	.55	6SF5GT	.45	7S7	.87	12SR7	.49	46	.45	
1A5GT	.40	2X2A	1.14	6BC5	.49	6SF7	.58	7V7	.87	12SR7	.49	47	.85	
1A7GT	.45	3A4	.44	6BE6	.37	6SG7	.40	7W7	.85	12Z3	.39	47	.85	
1A83	.38	3A5	.90	6BF5	.69	6SH7	.60	7X6	.57	14A4	.65	49	.38	
1B3GT	.67	3ABGT	.59	6BG6G	1.15	6SH7GT	.50	7Y6	.40	14A5	.67	50	.62	
1C5GT	.40	3B7	.39	6BH6	.45	6S7	.39	7Z4	.45	14A7	.53	50	.62	
1C7C	.37	3B6	.38	6B16	.41	6SK7	.39	7Z6	.49	14B7	.59	51	.56	
1D7GT	.75	31F4	.71	6BK7	.89	6SL7GT	.49	7Z7	.49	14B8	.63	56	.47	
1E7GT	.35	3Q4	.48	6BL7GT	.65	6SN7GT	.48	12A7H7GT	.85	14B8	.63	56	.47	
1F4	.40	3Q5GT	.63	6BN6	.42	6SQ7	.45	12AL5	.40	14C5	.80	57	.53	
1F5G	.44	354	.46	6BQ6GT	.75	6S7	.45	12AT6	.35	14C7	.65	58	.45	
1H4G	.40	3V4	.50	6BQ7	.88	6S7	.48	12AT7	.62	14E6	.65	70L7GT	1.00	
1H5GT	.38	5T4	1.25	6CA	.35	6T8	.57	12A06	.36	14E7	.80	71A	.52	
1J6G	.59	5U4G	.49	6C5	.39	6U7G	.45	12A07	.59	14F7	.65	72	.43	
1L4	.45	5V4G	.76	6C6	.54	6V8	.59	12A08	.44	14H8	.65	76	.42	
1L6	.45	5V6GT	.38	6C8G	.85	6V6	.48	12AV7	.64	14H7	.57	77	.53	
1LA4	.69	5Z3	.33	6B16	.42	6WAGT	.41	12B4G	.55	14N7	.67	78	.43	
1LA6	.75	6A5	.45	6C06G	1.05	6WG6T	.41	12AX7	.55	14Y4	.67	81	1.10	
1LB4	.77	6A7	.60	6D6	.67	6X4	.35	12AY7	.72	19	.45	82	.67	
1LC5	.59	6A8	.80	6D6	.67	6X5	.35	12B6G	.47	19B66G	1.15	83	.77	
1LC6	.75	6A8A	.42	6E5	.76	6X8	.70	12B7A	.59	19F8	.60	84	.57	
1LD5	.49	6AB7	.71	6F6	.45	7A4	.45	12B8G	.46	22	.40	85	.57	
1LE3	.49	6AC5GT	.63	6F7	.90	7A5	.59	12B9G	.65	25A5V5GT	.80	89Y	.29	
1LG5	.75	6AC7	.68	6F8G	.69	7A6	.65	12BH7	.65	25L6GT	.40	117L7GT	1.17	
1LH4	.75	6AF4	.89	6G6G	.63	7A7	.65	12C8	.34	25V4GT	.45	117Z3	.38	
1LN5	.62	6AF6	.75	6H6	.49	7AD7	.55	12F5GT	.35	25W4GT	.45	117Z6GT	.73	
1N5GT	.61	6AG5	.47	6J5	.38	7AG7	.55	45	.45	25Z6GT	.45	117Z6GT	.70	
1P5GT	.56	6AQ7	.90	6J6	.50	7AH7	.55	12J5GT	.39	25Z6GT	.45	117Z6GT	.70	
1Q5GT	.55	6AM6	.98	6J7	.50	7B5	.55	12J7GT	.57	26	.37	2051	.93	
1R4	.81	6AK5	.59	6J8G	.90	7B5	.55	12K8	.55	32L7GT	.95	807	1.45	
1R5	.47	6AL5	.35	6K6GT	.39	7B6	.55	12K8	.55	35C5	.37	814	3.50	
1S4	.55	6AQ5	.39	6K7G	.64	7C4	.55	12O7G	.57	35L6GT	.37	814	3.50	
1S5	.40	6AO6	.36	6K8G	.64	7C5	.65	12S8GT	.65	35W4	.59	832A	5.95	
1SA6	.48	6AQGT	.68	6L6G	.99	7E5	.59	12SA7GT	.62	35Y4	.44	866A	1.45	
1T4	.46	6AS5	.62	6L6GA	.99	7E6	.40	12SC7	.68					

1. We've specialized in selling vacuum tubes exclusively for many years.
 2. All tubes offered herein are obtained from Receiver Manufacturers' surplus, various govt. agencies and other surplus sources. Most of these tubes are brand new and the balance is removed from govt. and other equipment. WE UNCONDITIONALLY GUARANTEE EVERY TUBE YOU BUY.
 3. Our modern, completely equipped laboratories check every tube received. You are invited to see this special equipment in operation.
- Even though our inventories include almost every tube type made over the past 20 years—in quantities of more than a million assorted types—it is impossible to list every tube type. You are, therefore, urged to include any additional types required in your order.
- Minimum Order: \$10.00. Terms: 25% with order, balance C.O.D. Please include postage. All prices subject to change without notice.

TRANSAMERICA ELECTRONICS CORP.

115 LIBERTY ST., NEW YORK 6, NEW YORK

TARGET ANTENNAS FOR UHF and VHF

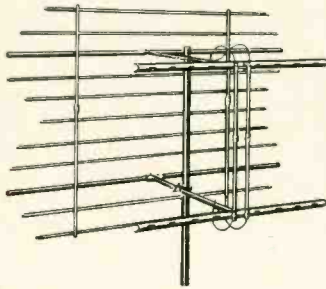

Model
FR88
List
\$34.95

Target "88" for maximum all-channel fringe area performance with highest front-to-back ratio and minimum side pick-up.

Model CR123
List \$10.50

UHF corner reflector for top performance in fringe areas. All-aluminum hurricane construction. A high quality antenna.

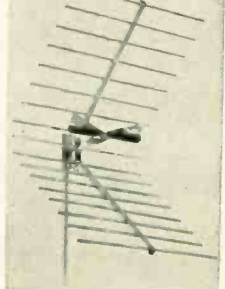

Also manufacturers of conical and Yagi-style antenna. The first to use Fiberglass insulators.

S & A ELECTRONICS

TOLEDO, OHIO

AUDELS T.V. RADIO SERVICE LIBRARY

HERE IS LATE INFORMATION IN A HANDY FORM FOR RADIO AND TELEVISION REPAIRMEN, SERVICEMEN AND STUDENTS

2 VOLS. \$6 COMPLETE \$1 MO. PAY ONLY 1 MO.



AUDELS T.V. RADIO SERVICE LIBRARY—Highly Endorsed—1001 Facts—Over 1562 Pages—625 Illustrations, Diagrams of Parts. Presents Important Subjects of Modern Radio, Television, Industrial Electronics, F.M., Public Address Systems, Auto, Marine & Aircraft Radio, Phonograph Pick-Ups, etc.

IT PAYS TO KNOW!

The Basic Principles—Construction—Installation—Operation—Repairs—Trouble Shooting. Shows How to get Sharp, Clear T.V. Pictures. Install Aerials—How to Test. Explains Color Systems, Methods of Conversion, Terms, etc. Includes Ultra High Frequency (U.H.F.)—Valuable for Quick Ready Reference & Home Study. Tells How to Solve T.V. & Radio Troubles—Answers Your Questions.

Get this Information for Yourself. 7 DAY TEST—ASK TO SEE IT!

MAIL ORDER
AUDEL, Publishers, 49 W. 23 St., N.Y. 10, N.Y.
Mail AUDEL T.V. RADIO SERVICE LIBRARY 2 vols. \$6 on 7 days free trial. If O. K. I will remit \$1 in 7 days and \$1 monthly until \$6 is paid. Otherwise I will return them.

Name _____
Address _____
Occupation _____
Employed by _____ RE

THE American IDEA

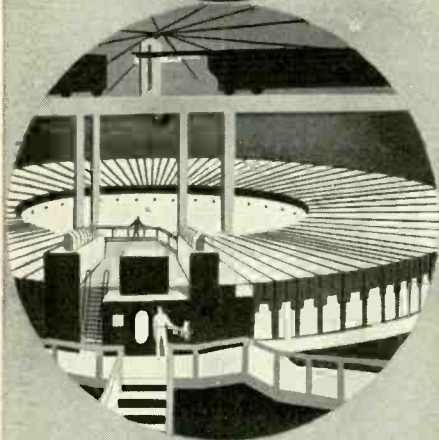

"To find and follow the better way"... Gigantic offspring of the cyclotron, the Bevatron—world's greatest magnet—can send masses of protons hurtling around its 135'-diameter race track at almost the speed of light. "Idea", to penetrate deep into the atomic nucleus, where lie secrets of matter and energy.

With us, the "American Idea" is, by directed effort and applied know-how, to continue to lead in bringing you electronic products of the highest quality.

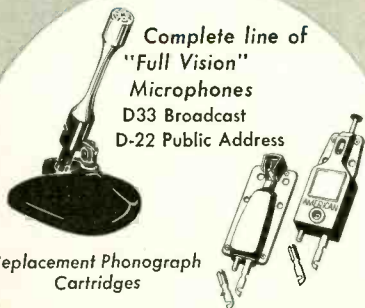

Complete line of
"Full Vision"
Microphones
D-33 Broadcast
D-22 Public Address

Replacement Phonograph
Cartridges

INSIST ON AMERICAN FOR QUALITY
Send for FREE Catalog 47

American microphone co.

370 South Fair Oaks Ave. • Pasadena, 1, Calif.

RADIO-ELECTRONIC CIRCUITS (Continued)

INTERVAL TIMER

Most electronic timers for photographic operations and other applications use R-C time constants to control the flow of current in a vacuum tube or thyatron. A novel device using a neon tube in the timing circuit was developed to give an audible indication at the end of a 30-, 60-, 90- or 120-second preset interval. This instrument, designed for timing the steps in operating a machine for cleaning watch parts, is described in *Wireless World*. It operates by push buttons and is readily adaptable to such photographic operations as printing, developing, washing and fixing. The circuit is shown.

Operation is as follows: Assume that the 30-second button is pressed. The 10- μ f capacitor begins to charge through the 3-megohm resistor. When the capacitor voltage rises to the striking voltage of the neon lamp, it conducts and current flows through the 50-ohm coil and operates the relay.

Contacts 1 and 2 are adjusted so they close and short-circuit the neon lamp before the other contacts operate. The remaining charge on the 10- μ f capacitor flows through the 50-ohm coil to fully actuate the relay. Contacts 7-8 open and 7-6 close to excite the 1,500-ohm relay coil through the 22,000-ohm resistor. Contact 4 swings from 5 to 3, thus converting the neon lamp from a timing element to a relaxation type audio oscillator to produce a tone in the earphone. The tone continues until one of the remaining push buttons is pushed to release the first one pressed. This removes excitation from the 1,500-ohm coil and resets the instrument for the next timed interval.

If you want the device to operate an external circuit, disconnect the leads from contacts 3, 4 and 5; remove the earphone, .01- μ f capacitor and the 100,000- and 500,000-ohm resistors, and use contacts 3, 4 and 5 for the external circuit.

The four push buttons are double-pole mechanically interlocked units like those used in some intercoms, tube testers and broadcast receivers. The relay is a double-coil type. The resist-

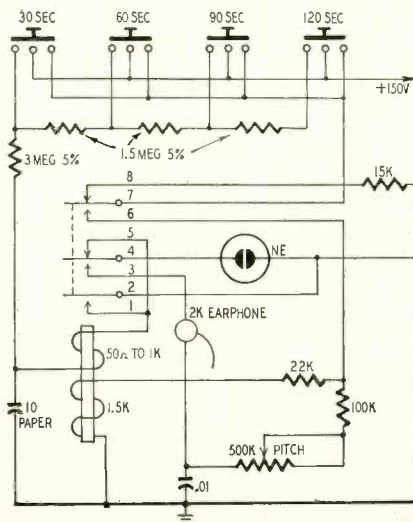

NEW! **SELL MORE TUBES... SAVE SERVICE TIME**

INDISPENSABLE ON EVERY TV SERVICE CALL... STORES IN TUBE CADDY—

\$29⁹⁵
SLIGHTLY HIGHER IN WEST

SECO PORTABLE GRID CIRCUIT TUBE TESTER

MODEL GCT-5, EQUIPPED WITH A FILAMENT VOLTAGE SELECTOR!

Now, quickly and positively check the grids of over 40 tubes in the critical AGC, RF, IF and Sync. circuits... performing a service no other tester can perform!

Speed Check "Foresees" Tube Trouble 4 Ways:

1. Control grid emission (Exclusive Feature!)
2. Grid to cathode shorts.
3. Gaseous condition in tube.
4. Cathode to heater shorts.

See your Jobber or write for information

SECO MFG. CO. / 5015 PENN. AVE. S. MINNEAPOLIS, MINN.

STEEL ANTENNA TOWERS

need no GUY WIRES

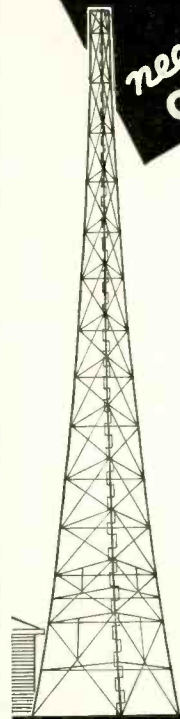

Improve radio and TV reception. Easy to erect... self-supporting 3 post towers... last a lifetime. Built of galvanized steel sections—no guy wires necessary—safe and resistant to high wind.

Available in heights of 33, 47, 60, 73, 87, and 100 feet.

TERRITORIES OPEN FOR JOBBER-DEALER FRANCHISE

Write for dimensions, structural details, prices, discounts, and available territorial assignments.

AERMOTOR COMPANY

Dept. 7004, 2500 Roosevelt Rd., Chicago 8, Ill.
BUILDERS OF STEEL TOWERS SINCE 1888

RADIO-ELECTRONIC CIRCUITS (Continued)

ance of the "operate" coil may be any convenient value between 50 and 1,000 ohms. The "hold" coil resistance may differ greatly from that shown. The series and hold-coil resistances may be adjusted so the circuit passes just enough current to hold the armature after it has been pulled in by the operate coil.

Timing can be adjusted by raising the B supply voltage or by inserting a series resistance in the B supply line. The value of the 15,000-ohm resistor from contact 8 to ground is adjusted so it passes the same amount of current as is drawn by the hold and tone-generating circuits combined. Adjust the value of this resistor accordingly when using an external tone or alarm circuit.

MOISTURE METER

There are a number of different types of instruments for measuring the moisture content of various solids and gasses. This simple moisture meter, described in *Electronic Engineering* (London, England), may be used to indicate, compare or measure the moisture content of wood, textiles, ceramics, paper, dry foods and other materials.

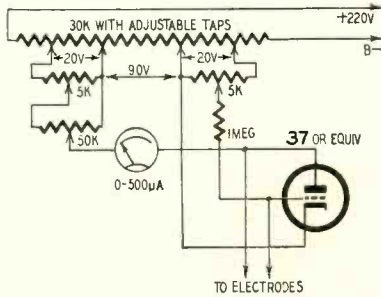

The triode is supplied with operating voltages from taps on a 30,000-ohm voltage divider. The indicating meter is in the plate circuit. The electrodes or test prods to be pressed against the material under test are connected to grid and plate. Since the resistance or conductance of an insulator or near-insulator varies with the amount of moisture, this resistance affects the meter reading when connected between grid and plate.

The initial reading is determined by the pressure of the electrodes against the sample so pressure should be raised until the meter reading becomes fairly stable.

The three potentiometers are for meter adjustment and calibration. Sensitivity can be increased by using a more sensitive meter or by increasing the spacing between electrodes. Decrease sensitivity by lowering the value of the grid resistance.

AUDIO SQUELCH

Audio squelch circuits vary greatly in design but nearly all of them are controlled by the a.v.c. voltage. Some use a d.c. amplifier or control tube to close a relay and open or short one of the a.f. grid, plate or voice coil leads

for your most complete
**EXACT REPLACEMENT
FLYBACK COVERAGE**

LOOK TO STANCOR

... whenever you need a flyback. The chances are you'll find a STANCOR exact replacement for the job!

There are 7 Admiral exact replacements that give you

**96% ADMIRAL
EXACT REPLACEMENT
FLYBACK COVERAGE**

There are 5 Muntz exact replacements that give you

**98% MUNTZ
EXACT REPLACEMENT
FLYBACK COVERAGE**

There are 10 RCA exact replacements that give you

**87% RCA
EXACT REPLACEMENT
FLYBACK COVERAGE**



FREE Reference library of STANCOR bulletins listing replacement applications for new STANCOR flybacks... from your Chicago Standard distributor

STANCOR transformers are listed in Photofact Folders Counterfacts File-O-Matic Radio's Master



**CHICAGO STANDARD
TRANSFORMER CORPORATION**

3592 ELSTON AVENUE • CHICAGO 18, ILLINOIS

EXPORT SALES:

Roburn Agencies, Inc.
431 Greenwich Street
New York 13, N. Y.



**CUT COSTS
NOW***

CHECK OUR PRICES ON

Branded tubes—guaranteed one year. All tubes individually boxed.

*Because of the tremendous response to our summer offer, this sale is being extended, for a limited time only.

**FREE—BANKERS APPROVED PEN
WITH EVERY ORDER**

SPECIAL—New—Jan 39/44—25 pes or more @ 15c

GENEVA ELECTRONICS of New York, 93-06 B Corona Avenue, Elmhurst 73, N.Y.

Type	Price	Type	Price	Type	Price
1B3	.59	6BG6	1.00	12AT7	.67
1R5	.48	6BL7	.78	12AU7	.55
1X2	.61	6BQ6	.70	12AV7	.67
5U4	.45	6CB6	.46	12BA6	.44
5V4	.55	6CD6	1.10	12BE6	.44
5Y3	.40	6H6	.38	12BH7	.57
6AB4	.46	6J5	.40	12SA7	.52
6AC7	.60	6J6	.40	12SK7	.50
6AG5	.46	6K6	.38	12SN7	.53
6AK5	.70	6SA7	.40	12SQ7	.49
6AL5	.42	6SK7	.40	19B66	1.38
6AT6	.38	6LS7	.59	25B06	.74
6AU5	.61	6SN7	.45	25L6	.40
6AU6	.40	6SQ7	.40	35L6	.40
6AV6	.38	6T8	.70	35W4	.40
6AX4	.55	6V6	.46	35Z5	.40
6BA6	.44	6W4	.40	50L6	.42
6BC5	.46	6W6	.51	117Z3	.38

Tubes not listed take 75% off list. 2% discount on orders over \$50—5% over \$75—10% over \$125

TERMS: 25% with order, balance C.O.D. Orders over \$15.00 with full remittance, prepaid to you in Continental U.S.A. Prices subject to change without notice. Minimum order \$10.00.

Handle Tough Service Jobs

AS "SLICK" AS YOU DO THE EASY ONES!

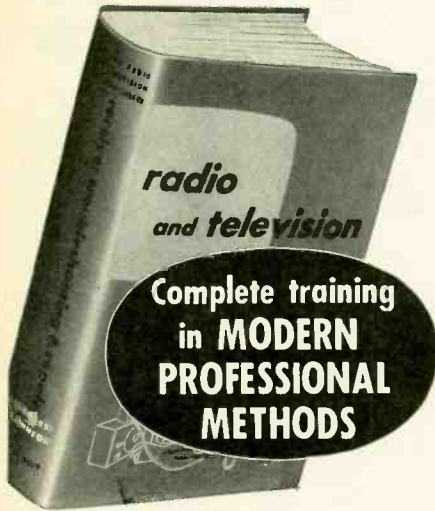

FIX ANY RADIO OR TV SET EVER MADE . . .

Easier . . . Better . . . Faster

How to troubleshoot the professional way

AM, FM and TV realignment made easy

Testing tips and ideas

A complete guide to TV service

Component problems and how to solve them

Special problems in Battery Sets, Communications Receivers, Recorders, etc.

Servicing, tuning and switching mechanisms.

. . . and dozens of other subjects

Owning this big, up-to-the-minute book is like having two of the world's greatest electronic experts standing by your side on every job . . . telling you just what to do, exactly how to do it!

Written by Ghirardi and Johnson, Radio & Television TROUBLESHOOTING AND REPAIR is a complete guide to modern professional methods . . . the kind that pay off big.

Step by step, it takes you through service procedures . . . from locating troubles fast and with less testing to making repairs accurately and promptly.

For beginners, this giant book is a complete service training course . . . at only a fraction of the price you might expect. For experienced servicemen, it is the ideal way to "brush up" on specific jobs; to develop better methods and shortcuts; and to find quick answers to problems that will enable you to handle tough jobs as fast and accurately as you now handle the easy ones.

Contains 820 big pages. Over 400 pictures, diagrams and charts make things doubly clear.

Remember! More men now in good servicing jobs get their training from Ghirardi books than any others of their type . . . and this new book is the latest and greatest of them all! Practice from it for 10 full days AT OUR RISK!

EXAMINE IT FREE!

Dept. RE-45, RINEHART & CO., Inc., 232 Madison Ave., New York 16, N.Y. Send Ghirardi's new Radio & TV TROUBLESHOOTING AND REPAIR book for 10-day FREE EXAMINATION. If I decide to keep book, I will then promptly remit \$6.75 (plus a few cents postage) in full payment. If not, I will return book postpaid and owe you nothing.

Name

Address

City, Zone, State
OUTSIDE U.S.A.—Price \$7.25 cash with order. Money back if book is returned within 10 days.

RADIO-ELECTRONIC CIRCUITS (Continued)

to silence the receiver in the absence of a signal of predetermined strength. This circuit, reprinted from *La Radio-Revue* (Antwerp, Belgium), is similar to the circuit on page 110 of the April 1954 issue in that it also uses a d.c. bias from the grid of an audio voltage amplifier.

V2 is the a.f. amplifier and V1 the control tube operating from the a.v.c. line. When the switch is closed and there is no signal coming in, V1 con-

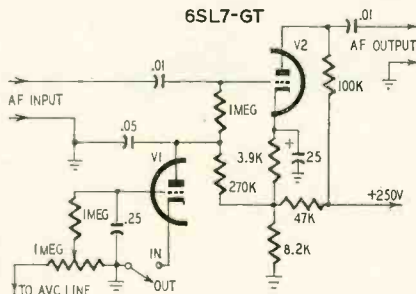

ducts to develop a voltage drop across the 270,000-ohm resistor and drive V2 to cutoff. When a signal is tuned in, the a.v.c. voltage rises sufficiently to cut off V1. This removes the voltage drop across the 270,000-ohm resistor and restores normal bias to V2 so it conducts and amplifies normally. The 1-megohm control in V1's grid circuit controls the sensitivity of the squelch circuit.

This type audio squelch circuit can be used in most communication receivers and is particularly useful where the receiver has to be kept on for long periods of time while no signals are being received. In noisy areas this circuit becomes one of the more important circuits in a receiver. END

CORRECTIONS

There is an error in the wiring of the bandswitch section in the plate circuit of the 6BE6 mixer in the all-wave tuner on page 168 of the January issue. This section of the switch should be wired so the primary of the 1500-kc i.f. transformer is shorted when tuning bands A and B and the primary of the 456-kc first i.f. transformer is shorted when tuning bands C and E.

We thank Robert E. Flanagan of Dorchester, Mass., for this correction.

Another error appears in Fig. 2 of the article "Gilding the Golden Ears" in the February issue. The 100,000-ohm grid-return resistors for the 1614's were inadvertently omitted from the diagram. These resistors connect from the left-hand ends of the 1,200-ohm series grid resistors to the ends of the 100-ohm balancing control.

In the same article, the time constant of the phase-shift network in the feedback circuit should be 1 microsecond rather than 10 microseconds as stated in the fourth paragraph on Page 95.

We thank Robert Sharpe of Ames, Iowa, for calling our attention to these errors.

GOT A DUD?



Completely Rejuvenate Pic Tubes Without Removing From Set!

\$54.95

No extras needed

MOST AMAZING MONEY MAKER SINCE MARCONI

Save on Trade-in TV Reconditioning . . . Save time, work & tube transportation on repair jobs. Cathode Rejuvenator Tester repairs as many as 80% of ALL pic tube troubles without removing tube. Also rejuvenates dim, yet not inoperative, tubes and predicts approx. life remaining—highly profitable service features, yet you avoid customer resentment. CRT pays for itself in few weeks, opens big new profitable tube repair market. Just plug it into a.c. and attach socket to tube. Tests for continuity, inter-element shorts, leakage, open circuits, grid cut-off, emission and predicts life expectancy. Then removes shorts, repairs open circuits, reactivates cathode to restore emission and new BRIGHTNESS. Weighs 5 lbs. in carrying case. No accessories needed. Simple instructions with order. Guaranteed to perform as described or money back. Order Model 350 today!

Specials From The Bargain Counter!

10 Watt Wire Wound Resistors	Famous Make Tubular Electrolytic Conds.		
Almost 1/3 price! 10 ohms—50,000 ohms in standard values . . . 25c each.	MTD-1520 20-20mf -150 V . . . 55c	MTD-301 50-30mf -150 V . . . 59c	MT-4508 8mf-450 V . . . 45c
	In lots of 10 50c each	In lots of 10 55c each	In lots of 10 39c each

Write for FREE FYI Bulletin 219

WHOLESALE RADIO PARTS CO., Inc.

311 W. Baltimore St.

Baltimore 1, Md.

Build it Yourself!



ARTISAN

ELECTRONIC ORGAN

SAVE hundreds of dollars with our easy-to-assemble kits. Designed to sound and look like a pipe organ. Send \$1.00 for "ORGAN BUILDERS MANUAL," Complete Plans for several models, plus our large parts Catalog.

ELECTRONIC ORGAN ARTS Dept. E, Box 41084, Los Angeles 41, Calif.

EASY TO LEARN CODE

It is easy to learn or increase speed with an Instructograph Code Teacher. Affords the quickest and most practical method yet developed. For beginners or advanced students. Available tapes from beginner's alphabet to typical messages on all subjects. Speed range 5 to 40 WPM. Always ready—no QRM.



ENDORSED BY THOUSANDS!

The Instructograph Code Teacher literally takes the place of an operator-instructor and enables anyone to learn and master code without further assistance. Thousands of successful operators have "acquired the code" with the Instructograph System. Write today for convenient rental and purchase plans.

INSTRUCTOGRAPH COMPANY

4701 Sheridan Rd., Dept. RC, Chicago 40, Ill.

RADIO-ELECTRONICS

Question Box

PHONO CONNECTION FOR TV

I am enclosing the diagram of my TV receiver. Please show how I can connect a record player and cut off the picture tube. I don't get enough gain when I feed the record player into the high end of the volume control in the grid circuit of the 25BK5 audio output tube.—R. N., Caracas, Venezuela

You can either use a phonograph pre-amplifier between the pickup and volume control or modify one of the existing r.f. or i.f. tubes so it serves as an audio amplifier for the phonograph.

The diagram shows the audio circuit of your TV receiver with the 6BN6 detector modified to work as an audio amplifier for phono reproduction. A 4-pole double-throw switch, two resistors and one capacitor are needed for the conversion.

S1-a opens the B plus line to the 6AN8 sound i.f. amplifier to prevent interference between the TV and phonograph. S1-b connects a high positive voltage to the cathode of the picture tube to darken the screen. S1-c grounds the 6BN6 cathode for proper operation as an audio amplifier and S1-d inserts the R-C network needed for connecting the pickup. Leads and components that must be added are shown by dashed lines.

S1-a opens the B plus line to the 6AN8 sound i.f. amplifier to prevent interference between the TV and phonograph. S1-b connects a high positive voltage to the cathode of the picture tube to darken the screen. S1-c grounds the 6BN6 cathode for proper operation as an audio amplifier and S1-d inserts the R-C network needed for connecting the pickup. Leads and components that must be added are shown by dashed lines.

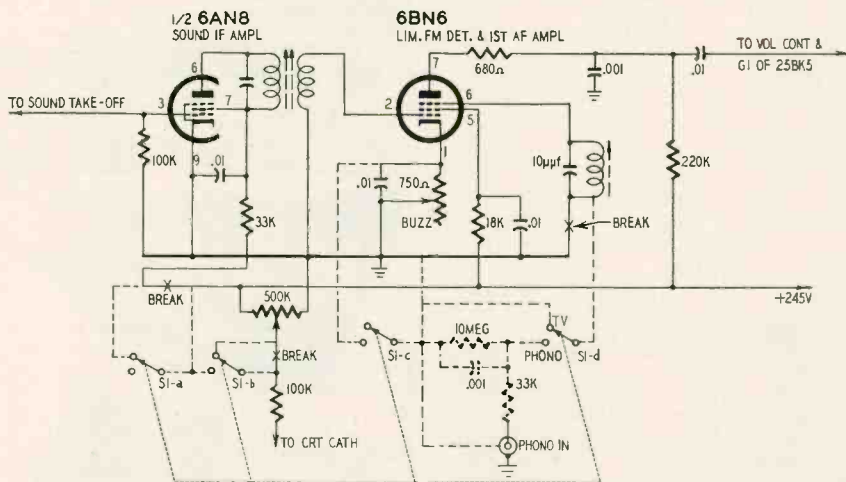

CITIZENS BAND PROBLEMS?

Please print construction details and a schematic of a transceiver with a range of about 20 miles. I would like to use transistors and operate in the 465-mc citizens band.—A. C. B., Reno, Nev.

The citizens band is for the use of large numbers of citizens with no technical knowledge of radio so the FCC has set up very rigid specifications on transmitter stability, modulation capability and spurious radiations as well as on receiver reradiation to prevent avoidable interference and confusion.

The problem of successfully constructing citizens-band transmitters is not so much one of circuitry as it is one of layout and mechanical construction that must be used to meet the rigid technical requirements of the band. If you construct your own equipment you will have to satisfy the FCC that it fully complies with either class A or class B station requirements before a license will be issued. The commission

may require you to send the equipment or a prototype to its laboratory for tests.

A considerable amount of experience with the design and construction of u.h.f. transmitters and receivers and precision laboratory equipment for checking transmitter characteristics are prime requisites for anyone attempting the construction of citizens-band 465-mc transmitters or transceivers. Therefore, we feel that it is very unlikely that amateur experimenters and constructors will be able to meet the FCC specifications for a number of years. Your best bet is to use commercial transceivers such as the Stewart-Warner model 73 *Portafones*.

Work with transistors has not progressed sufficiently for anyone outside of one or two laboratories to consider using them at frequencies much higher than the broadcast band, although some experimental transistors have been op-



THE NEW PRECISION MODEL 88

HIGH SENSITIVITY VTVM and ELECTRONIC OHMMETER Complete with 3-way Universal Test Probe PEAK TO PEAK VOLTAGE RANGES TO 3200 VOLTS

A compact wide range VTVM-Ohmmeter for modern electronic circuit checking in the laboratory, on the production line and for general service-maintenance. Features include Peak-to-Peak voltage ranges which afford a new high in P-P reading accuracy of pulsed wave-forms in color or monochrome TV and similar applications.

7 DISTINCTLY SEPARATE FUNCTIONS 40 SELECTED, WIDE-SPREAD RANGES

- ▶ 6 TRUE-ZERO-CENTER DC VOLT RANGES: Constant 26 $\frac{2}{3}$ Megs input resistance. 0 \pm 1.2 \pm 6 \pm 12 \pm 60 \pm 300 \pm 1200 volts.
- ▶ 5 ELECTRONIC OHMMETER RANGES: 0-1000-10,000 ohms. 0-1-100-1000 Megs.
- ▶ 6 PLUS and 6 MINUS DC VOLT RANGES: (Left-Hand-Zero) constant 13 $\frac{1}{3}$ Megohms Input. 0-1.2-6-12-60-300-1200V.
- ▶ 6 HIGH IMPEDANCE RMS AC VOLT RANGES: 0-1.2-6-12-60-300-1200 volts. Input Characteristics: Up to 60V Range - 3 Megs., 90 mmfd; 300 V Range - 1 Meg., 70 mmfd; 1200V Range - 4 Megs., 67 mmfd.
- ▶ 6 HIGH IMPEDANCE P-P AC VOLT RANGES: 0-3.2-16-32-160-800-3200 volts. Input Characteristics: Up to 160V Range - 6 Megs., 90 mmfd; 300V Range - 1 Meg., 70 mmfd; 3200V Range - 4 Megs., 67 mmfd.
- ▶ 5 SPECIAL HIGH FREQUENCY PROBE RANGES: 0-1.2-6-12-60-300 volts RMS. (Requires optional PRECISION RF-10A HF Probe). Probe input capacity:—approximately 5 mmfd.
- ONE UNIVERSAL COAX. AC-DC VTVM PROBE serves all functions other than HF ranges.
- PEAK-TO-PEAK "RE-SET" PUSH-BUTTON for rapid "zero" return of special electronically damped test circuit.
- EXTRA-LARGE 5 $\frac{1}{4}$ " RUGGED PACE METER. 200 μ A sensitivity \pm 2% accuracy.
- 1% MULTIPLIERS and SHUNTS.

MODEL 88: complete with detachable AC line cord, internal ohmmeter battery, coaxial VTVM Probe and operating manual. Size: 5 $\frac{1}{2}$ x 7 x 3 $\frac{1}{2}$ "...\$69.75 net

ACCESSORIES FOR THE MODEL 88
RF-10A HF vacuum tube probe \$14.40 net
TV-8 60 Kilovolt safety probe 14.75 net
ST-1 Snap-on foldaway tilt-stand 1.00 net

PRECISION APPARATUS CO., INC.

70-31 84th Street, Glendale 27, L. I., N. Y.
Export: 458 Broadway, New York 13, U. S. A.
Canada: Atlas Radio Corp., Ltd., 560 King St. W., Toronto 28

NEW WIDE BAND TELEVISION Oscilloscope

For Black and White and COLOR TV
For AM or FM Receivers
For High Fidelity Amplifiers
For Industrial Electronic Equipment



Only **\$33.50** with order

and \$20 per month for 6 months
Hard jobs made easy... no more guesswork. Many laboratory-type features. Easy to understand instruction manual. Factory wired and calibrated—standard RETMA warranty.

Vertical Amplifier ± 3 db from 10 cps to 4.5 mcs. Linear Sweep range 10 cps to 100 kc. Vertical Attenuator calibrated to read peak-to-peak volts direct up to 1000 volts. Sensitivity, .014 (rms) volts per inch of deflection. Positive and negative sync. Calibrating signal. Voltage-regulated power supply. Balanced, push-pull deflection in both vertical and horizontal amplifiers.

Twelve Tubes and Latest Circuitry give Top Performance.

Compare these features with scopes costing twice as much—and more. You'll find this is the ideal scope for your AM, FM and TV servicing jobs... and it will fit your need for future color servicing, Hi-Fi and many other uses. This is a top quality, exceptionally well built piece of professional equipment. Mail the coupon now for FREE descriptive circular with details of operation, performance specifications, interesting facts.

MAIL THIS FOR FREE CIRCULAR

National Radio Institute, Dept. 4-RE
16th & U Streets, N.W., Washington 9, D.C.
Send me, without obligation, descriptive illustrated circular on your new Wide-Band Professional TV Scope.

Name.....
Address.....
City..... Zone..... State.....

QUESTION BOX (Continued)
erated in the hundreds of megacycles. Construction and design of a satisfactory transistorized transceiver for frequencies as low as 2 mc are the result of many weeks of planning and experimenting. A few licensed amateurs have constructed transistorized transmitters for the 160-meter band. Power input is generally around 35 milliwatts and the range is about 2 miles with a good long-wire antenna and a sensitive communications receiver.

PHONO MODIFICATION

I am dissatisfied with my new record player because it does not have enough volume. I've heard less expensive units with more. All components and voltages check O.K. I'm sending the diagram of the player. Please show how I can modify it.—E. S. T., Brooklyn, N. Y.

According to the catalog data, the Astatic 16L3 cartridge in the play-

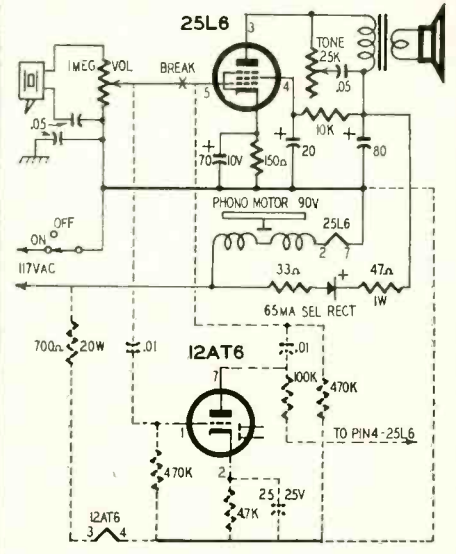

er develops about 4 volts output from the average record. The 25L6 tube requires a peak grid signal of 7.5 volts for maximum output of 2.1 watts. But since only 1 watt from a good speaker is too much for ordinary home listening, we feel that the output of the cartridge may have dropped considerably.

The first step is to check the cartridge output with a v.t.v.m. across the volume control.

If the average record produces voltages within normal tolerances, you can increase the output by increasing the gain with a voltage amplifier stage. The diagram shows the circuit of your amplifier with a 12AT6 preamplifier and its circuitry shown in dashed lines.

GOLDEN EAR CONTROL

I'd like to use the Centralab C3-300 dual tone control that Mr. Marshall mentions for the Golden Ear control unit but I cannot find it listed in Centralab or mail-order catalogs. Please give the correct part number.—H. G., Willowbrook, Calif.

The C3-300 is a special unit not listed in general catalogs but readily available from Centralab distributors for \$4.50.

NEW! ATLAS CJ-30 COBRA-JECTOR INDESTRUCTIBLE FIBER-GLASS ALL WEATHER WIDE ANGLE DISPERSION



List \$40.00
NET \$24.00

Complete with Driver.

Weatherproof Line Matching Transformer as shown, Net \$5.10.

New versatile all-purpose projector—excellent for paging & talk-back, intercom, marine, and industrial voice & music systems. Penetrating articulation assures wide angle intelligible coverage even under adverse sound conditions. "ALNICO-V-PLUS" magnetic assembly. Double-sealed against all weather. Omni-directional mounting bracket. Quick, easy installation. An amazing "power package"—Specify the CJ-30 for the "tough" jobs!

Input Power (continuous)	15 watts
Input Impedance	8 ohms
Response	250-9000 cps
Dispersion	120° x 60°
Dimensions:	Opening, 14" x 6"
	Overall Length, 14"



WRITE FOR COMPLETE CATALOG
ATLAS SOUND CORP.
1443—39 St., Bklyn. 18, N. Y.
In Canada: Atlas Radio Corp., Ltd., Toronto, Ont.

This useful scope book now in a hard-cover edition!

THE OSCILLOSCOPE—By George Zwick. 192 Pages. Cloth-bound edition. \$4.00



A book every successful service technician needs! Tells you in simple words and diagrams how to get the most out of your scope in servicing. The paper-bound edition sold thousands of copies in a few months. Now, by popular demand, a new durable cloth-bound edition to stand the gaff of on-the-bench use. Order your copy today—only a limited quantity available.

CONTENTS

- Waveforms
- The C-R Tube
- Sweep Systems
- Typical oscilloscopes
- Alignment
- Oscilloscope Techniques
- Tests and Measurements
- Measurement Using the Oscilloscope

Mail This Coupon Today

Gernsback Publications, Inc., Dept. 45
25 West Broadway
New York 7, N.Y.
I am enclosing \$4.00 for which please send me postpaid the hard-cover edition of The Oscilloscope.
Name.....
Street.....
City..... Zone..... State.....

MARINE-BAND CONVERSION

Several small-boat owners have asked me to convert typical 3-way portable broadcast receivers to receive the 2-3-mc marine band. Please print a diagram showing the alterations.—J. V. M., La Habra, Calif.

The diagram shows the front end of a typical 3-way or battery portable

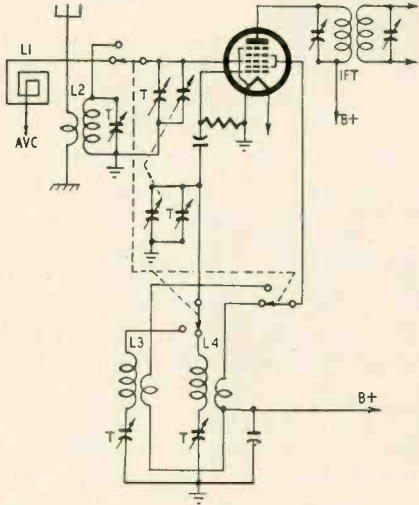

with an added shortwave band.

L1 is the usual loop or high-Q ferrite antenna coil and L4 the broadcast oscillator coil. L2 and L3 are miniature antenna and oscillator coils, respectively, for the 2-6-mc band. A miniature 3-circuit 2-position wafer switch is used for shifting from one band to the other.

Note that many portables have a cut-plate oscillator tuning capacitor with a maximum capacitance of around 145 μf while the antenna section has a maximum capacitance ranging from about 240 to 420 μf . This 2-gang tuning capacitor should be replaced with one having a maximum capacitance of 365 μf per section to insure tracking on the shortwave band.

RIAA COMPENSATION

Please print a diagram showing the modification of a G-E type A1-900 compensator to produce the new RIAA playback curve.—J. F., Brightwaters, N. Y.

G-E informs us that when the A1-900 compensator is used with the UPX-003A or similar preamplifier the AES curve runs within 2 db of the RIAA curve between 40 and 15,000 cycles so the AES position is satisfactory for the new curve.

It was also pointed out that the actual response of recordings may deviate several db from the theoretical because of studio absorption characteristics, orchestral balance, microphone directivity, tonal preference of the recording engineer and other factors. Remember also that curve deviations of several db may develop on playback where room acoustics, speaker response and the type of enclosure all have a direct bearing on playback characteristics. **END**

**FOR SERVICE DEALERS, from TRANSVISION-
8 MONEY-MAKERS**

**THESE FINE, LOW COST INSTRUMENTS PAY FOR THEMSELVES QUICKLY!
Necessities for black-and-white TV, a MUST for COLOR TV!**

1 TV Component Tester
PERFORMS 6 VITAL FUNCTIONS



The industry's biggest value! SIX instruments in one compact unit—terrific as a PICTURE TUBE TESTER... FLYBACK & YOKE TESTER... SELENIUM RECTIFIER TESTER... CONDENSER TESTER... CONTINUITY TESTER... PICTURE TUBE REACTIVATOR.

You get \$176 worth of Testing and Repair Instrumentation in 1 efficient unit for the amazing low price of only

\$49.95

5 Field Strength Meter
For Battery Operation and 110 V AC



Saves 50% of installation cost... Measures pic signal strength directly from antenna... Identifies TV, FM, TVI signals... Has 12 channel selector; multiplier switch for weak signal areas... Range is 10-50,000 microvolts... A must in fringe areas. UHF or VHF.

Model FSM-5B, for Battery Operation and 110V AC. Weight 22 lbs. net

\$89

2 Make Big Profits with this Tester-Reactivator Sparker

A complete picture tube testing and repair unit. It TESTS picture tubes—measures Cathode emission, locates shorts between elements; locates high resistance shorts or leakage as high as 3 megohms. REACTIVATES dim tubes without removal from set... SPARKS OUT high resistance shorts in CRT'S and other tubes.



\$34.95

3 CRT TESTER—REACTIVATOR
Same as Tester-Reactivator-Sparker, but without Sparker, only

\$19.95

4 CRT SPARKER
SPARKS OUT high resistance shorts in CRT'S and other tubes by application of 15,000 volts of RF. only

\$19.95

6 Flyback—Yoke—Continuity Tester ... in 1 low cost unit

Checks low and high impedance Yokes and Flybacks... Detects even one shorted turn... An improved Continuity Checker: Checks condensers for opens, electrical shorts, or leakage. (Ordinary continuity testers will not do this).



A \$59 value for **\$24.95**

Complete line of COIN TV SETS

Also COIN BOXES for operating any TV set. Many unusual, profit-making features; only \$14.95. Ask for complete details—today.



8 Install the Finest MASTER AMPLIFIED and COMMUNITY TV ANTENNA SYSTEMS

Let Transvision help solve your problem with FREE engineering advice. Also write for—

FREE Technical Manual for Community and Master TV Systems. Write for it now.

Now... for the first time!

Servicemen can make money from HI-FIDELITY

Get into HI-FI with an investment of only \$4.95**

TRANSVISION offers you the MOST COMPLETE line of MATCHED HI-FI UNITS—finest at any price, including:

- 15" Dual Speaker Systems
- Imported English Record Changer with Diamond Needle
- Superb Amplifiers and AM-FM Units, designed for easy installation
- Complete cabinet assortment for every taste and budget.

We enable you to UNDERSELL ALL COMPETITION and give you FULL PRICE PROTECTION.

**How? Write, wire, phone for our unique "Dealer Hi-Fi Program".

WRITE FOR CATALOGS

JOBBER INQUIRIES INVITED

TRANSVISION, INC., NEW ROCHELLE, N. Y. Dept. E4

Send me.....

Enclosed find \$..... deposit. Balance C.O.D.

My JOBBER is.....

Name.....

Address.....

City..... State.....

E. E. or

PHYSICS

GRADUATES

with experience in

RADAR or

ELECTRONICS

or those desiring to enter these areas...

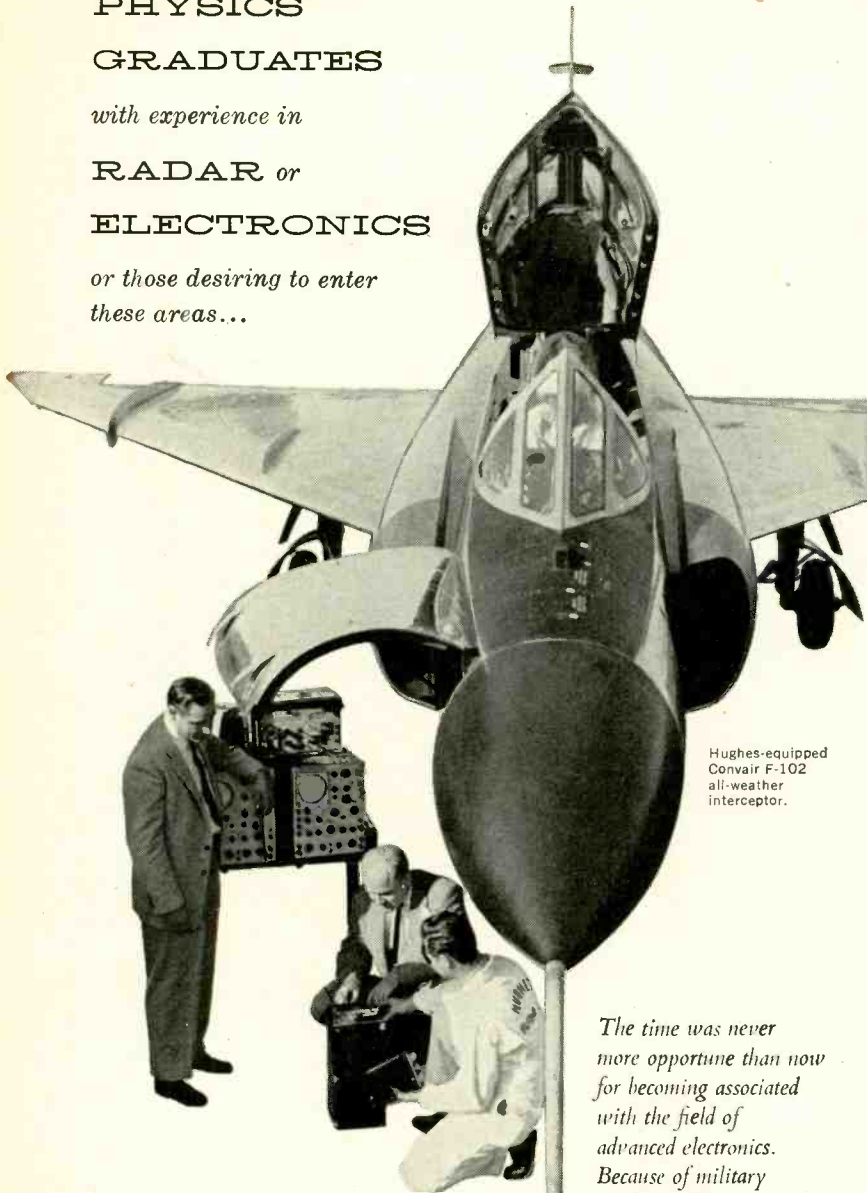

Hughes-equipped Convair F-102 all-weather interceptor.

The time was never more opportune than now for becoming associated with the field of advanced electronics. Because of military emphasis this is the most rapidly growing and promising sphere of endeavor for the young electrical engineer or physicist.

Since 1948 Hughes Research and Development Laboratories have been engaged in an expanding program for design, development and manufacture of highly complex radar fire control systems for fighter and interceptor aircraft. This requires Hughes technical advisors in the field to serve companies and military agencies employing the equipment.

As one of these field engineers you will become familiar with the entire systems involved, including the most advanced electronic computers. With this advantage you will be ideally situated to broaden your experience and learning more quickly for future application to advanced electronics activity in either the military or the commercial field.

Positions are available in the continental United States for married and single men under 35 years of age. Overseas assignments are open to single men only.

SCIENTIFIC AND ENGINEERING STAFF

HUGHES

RESEARCH AND DEVELOPMENT LABORATORIES

Culver City, Los Angeles County, California

Relocation of applicant must not cause disruption of an urgent military project.

Patents

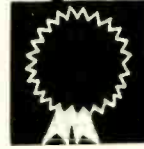

H. F. PROBE

Patent No. 2,685,673

Jack Avins, New York, N. Y. (Assigned to Radio Corp. of America)

Suitable for a v.t.v.m. or a scope, this probe features a triode cathode follower to isolate the signal and reduce loading.

An ideal probe network is shown in Fig. 1. When $R1 \times C1$ equals $R2 \times C2$, no frequency distortion exists. Values $R2$ and $C2$ are unavoidable, since they represent distributed quantities across the probe tube. Capacitor $C1$ is an isolating unit, and $R1$ must be added to preserve the time-constant relationship.

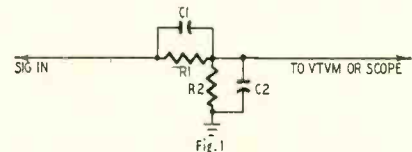

In an actual probe, the ideal circuit is not obtained because of capacitance between the prod and ground. Instead of $C1$, capacitance exists directly to ground and a flat frequency response is not possible. Fig. 2 shows how this

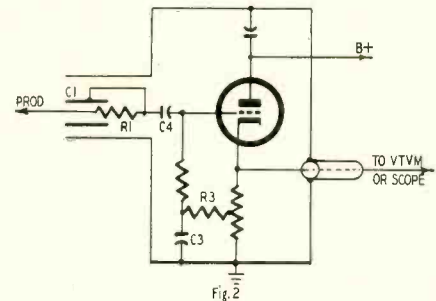

invention solves the problem. An intermediate shield reduces capacitance between prod and ground and transfers the capacitance across $R1$ as desired. Blocking capacitor $C4$ is relatively large and $R3-C3$ is a filter that prevents feedback from cathode to grid. Values $R2-C2$ are not shown in Fig. 2, but they exist across the triode input.

WIDE-BAND TV ANTENNA

Patent No. 2,691,730

Yuen Tze Lo, Ellenville, N. Y. (Assigned to Channel Master Corp.)

This antenna has high gain, good directivity and uniform impedance over the entire v.h.f. band. It uses three dipoles, one tuned to about 65 mc and the others to about 195mc. Thus the antenna lengths are harmonically related. Fig. 1 shows the arrangement of the dipoles. The longest one is mounted between the other two.

At the lower end of the band the short dipoles contribute almost nothing, so only the longer antenna is effective. At the high end all three

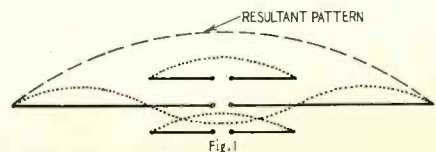

dipoles pick up considerable energy. The dotted lines (Fig. 1) show the current distribution at the higher frequencies. As expected, the long dipole has an out-of-phase portion at the center, since it is a 3/2-wavelength wire. Ordinarily such a long wire cannot be used because of this phasing effect. In this case, however, the undesirable current distribution is cancelled by one of the shorter dipoles. This leaves the pattern shown by the dashed line. Thus the antenna acts just like a single dipole throughout the v.h.f. band.

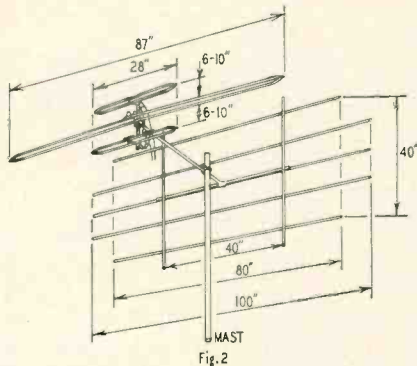

A complete antenna with reflector is illustrated in Fig. 2. The dipoles are of the folded type, the shorter ones being above and below the long dipole. The distance between dipoles is about 6-10 inches. Other dimensions are given in the diagram. The reflector is made of vertical and horizontal rods in back of the dipole array. It adds 7-db gain and increases directivity.

SPECIAL-EFFECTS CONTROL FOR AUDIO AMPLIFIER

Patent No. 2,692,306

Jarrett L. Hathaway, Manhasset, N. Y., and Raymond E. Lafferty, Fair Lawn, N. J. (Assigned to Radio Corp. of America)

Amplifiers used for broadcasting and recording are often equipped with *automatic audio gain control* to prevent overloading and maintain a high percentage of modulation. The a.a.g.c. muffles louder sounds such as those of gunfire or thunder so the dramatic impact is lost. This new circuit passes these special effects by disabling the a.a.g.c. temporarily and automatically.

The audio signal is passed through an amplifier, an inverter and a gain control stage. Output from the lower 6SA7 feeds an amplifier-rectifier which provides a.a.g.c. bias. After R-C filters out the higher-frequency components, the bias is fed back to the 6SA7 grids.

The signal at the cathode of the inverter is transmitted through the 1N54 diode, which is normally blocked by two bias supplies. When a

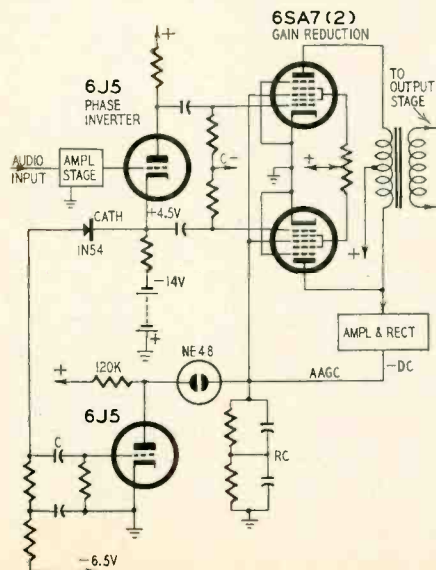

TEMPERATURE HIGH? HUMIDITY LOW?



TRY THE TAPE TEST

Make this simple test on the VTVM you're using now. Take a strip of plastic electric tape... press it firmly over the meter face... then pull it off with one quick, sharp tug. Notice that meter deflection? Notice how long it takes to re-zero?

Now, try the same test on a Hycon VTVM. You'll see little meter deflection... and immediate re-zeroing. Hycon's electrostatic shielding is your assurance that even when temperature's high and humidity's low... common conditions around computers, GCA systems and transmitters... you'll get out of your VTVM all the accuracy Hycon builds into it.



MODEL 614 VTVM

Accuracy at unprecedented low cost... 21 ranges (28 with p-p scales); large 6 1/2" meter; 3% accuracy on DC and ohms, 5% on AC; AC frequency response to 250 MC (with accessory crystal probe). *Test probes stow inside case.*

\$87.50

MODEL 617 3" OSCILLOSCOPE

Designed specifically for color TV and laboratory requirements... 4.5 MC vertical bandpass, flat within ± 1 db; high deflection sensitivity (.01 v/in. rms); flat face 3" CRT. *Sharp undistorted trace edge to edge.*

\$269.50

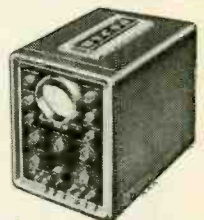

See and try these matched, bench-stacking instruments at your local electronic parts jobber.

Hycon Mfg. Company
2961 EAST COLORADO STREET • PASADENA 8, CALIFORNIA

"Where accuracy counts"

ORDNANCE • AERIAL CAMERAS • ELECTRONIC SYSTEMS • BASIC ELECTRONIC RESEARCH
ELECTRONIC TEST INSTRUMENTS • AERIAL SURVEYS • GO NO-GO MISSILE TEST SYSTEMS

Announcing the **NEW** **SANGAMO Type 36**

PLUG-IN TUBULAR PAPER CAPACITOR



Your answer to those calls for a **PRINTED CIRCUIT REPLACEMENT CAPACITOR**

Perhaps you've already had calls for printed circuit replacement capacitors. Now you can offer your customers the first mass produced capacitors for printed circuit chassis. Remember, the new Type 36 plug-in tubular is an exact replacement for most of today's new printed circuit chassis. To stock up now, see your Sangamo jobber or write direct.



**MOISTURE-
RESISTANT
END FILL**



**BAKELITE
MOLDED CASE**



**LEADS ARE CUT
AND PROPERLY
SPACED TO FIT**

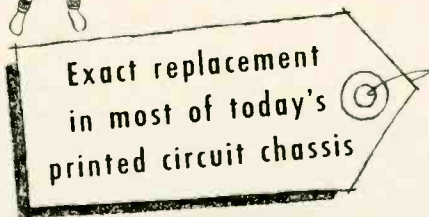

SC55-4



SANGAMO ELECTRIC COMPANY

MARION, ILLINOIS

PATENTS

(Continued)

very loud sound arrives, bias is overcome. The diode conducts *negative* pulses through capacitor C to a triode. The output of this tube consists of *positive* pulses. These ignite the NE48 neon bulb and neutralize the a.a.g.c. voltage. During the interval of the loud sound effect, the a.a.g.c. is disabled and the full blast of gunfire or thunder is transmitted through the amplifier.

2-WAY TRANSISTOR AMPLIFIER

Patent No. 2,691,073

Roderic V. Lowman, Westbury, N. Y. (Assigned to Hazeltine Research, Inc., Chicago)

This amplifier transmits audio in two directions without need for switching. It is shown here connecting two stations, each equipped with a microphone and speaker. The transistor may be a junction or point-contact type. V is a source of a.c. at approximately 50 kc.

In the diagram, the transistor is assumed to be an n type point-contact or a p-n-p junction. During half the a.c. cycle, element A is driven positive while B goes negative. Therefore, during this time, A acts as emitter, B as collector, and the transistor amplifies in a left-to-right direction. D1 is blocked by negative bias. D2 conducts through the emitter-base path. During this half-cycle, D4 is blocked by a positive bias at its cathode. D3 conducts. Note that impedance relations are correct. The emitter load is only a portion of the T1 secondary, so it has low impedance. The collector feeds into the entire winding of T2.

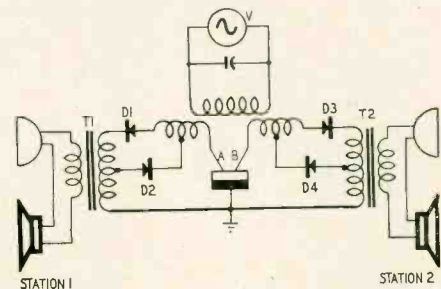

During the next half-cycle of a.c., polarity is reversed. A acts as collector and B becomes the emitter. Signal transmission is now in the reverse direction, from station 2 to station 1. Impedance matching is correct again, for D2 and D3 are the diodes that block during this half-cycle.

Due to the rapid reversal of polarity of V, normal audio communication is readily carried on.

Most transistors are chemically formed so that one element (or point contact) makes a better emitter than the other element. In these cases transmission will not be equally effective in both directions. If this forming process is omitted, gain will be equal in both directions.

VOLTAGE REGULATION

Patent No. 2,693,568

Fay H. Chase, Short Hills, N. J. (Assigned to Bell Telephone Labs., Inc.)

This voltage regulator uses transistors and operates on either d.c. or a.c. It is compensated against variations due to temperature.

Three n-p-n transistors appear in the diagram. V1 is the control unit. When the output voltage rises, for example, P feeds more positive potential to the base. In an n-p-n semiconductor this means greater conduction, so flow increases through R1, V1, R2, B. The increased current through R2 varies V3 bias and lowers its conductivity. V3 is in series with the load, therefore the tendency for the output voltage to rise is cancelled out.

When temperature rises, V1 conducts more easily and (as shown above) this means lower output voltage. To eliminate this variation with ambient temperature, V2 is added. The higher temperature increases its conductivity and this drives more current through R1. Therefore V1

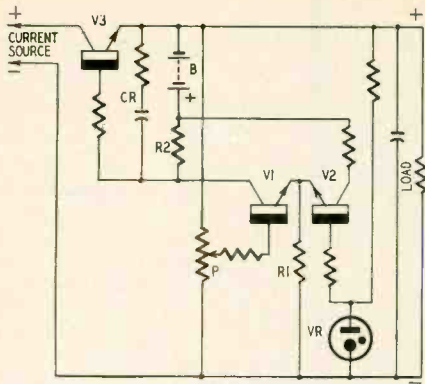

is biased toward lower conduction, which, of course, cancels the temperature effect. Note that the bias for V2 is held constant by a V-R tube. C-R prevents rapid changes of current from being amplified and fed back to cause "singing" and oscillation.

This circuit is also effective when the current source is a.c. In this case V3 rectifies the current, so the output is d.c.

WAVEGUIDE LINE

Patent No. 2,688,732

Winston E. Kock, Basking Ridge, N. J. (Assigned to Bell Telephone Labs., Inc.)

Recent patents have disclosed how a row of rods or pins can guide microwave energy. Such a guide line is shown in Fig. 1. Waves radiating from a rectangular horn are made to follow a line of rods to be received by a second horn. The rods may be of any good conductor such as copper or brass and may be held in place by wood posts or other insulators. In a typical line designed for waves of 3.2 cm. dimensions are:

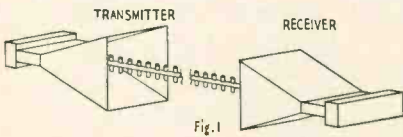

rod diameter, 1/8 inch; rod length, 5/16 inch; spacing, 1/8 inch. Loss per meter length of line is only a small fraction of a db.

This invention deals with new applications for guide lines. Fig. 2 shows how to guide waves around a curve. Near the curve the rods

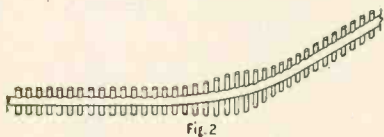

must be made longer than usual to prevent the waves from going off into space. To change the polarization of a wave, the direction of the rods must be twisted gradually, from a vertical to a horizontal plane or vice versa. END



"Be sure you push it back to the kitchen before you come to bed!"

... and if you need
**PLUG-IN
ELECTROLYTICS**
Sangamo's got them too!

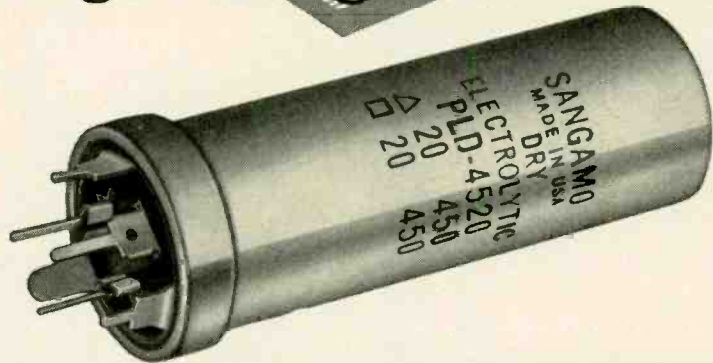

Your answer to those calls for a
**PRINTED CIRCUIT
REPLACEMENT CAPACITOR**

You're bound to have more calls for plug-in electrolytic replacement capacitors for printed circuit chassis because more and more manufacturers are using printed circuits in the assembly of their television receivers.

Sangamo's dry electrolytic plug-in capacitors are exact replacements for most of the new sets with printed circuit chassis. Stock up now!

See your Sangamo jobber or write to us direct.



SANGAMO ELECTRIC COMPANY
MARION, ILLINOIS

SC55-4

a HIT in High Fidelity with COLLINS AUDIO PRODUCTS CO. 'PRE-FAB' TUNERS

Collins Audio Products Co. is in no way affiliated with Collins Radio Co.

Each Collins Tuner Kit is complete with punched chassis, tubes, power transformer, power supply, components, hardware, dial assembly, tuning eye, knobs, wire, etc., as well as the completed sub-assemblies: FM tuning units, AM tuning units, IF amplifiers, etc. All sub-assemblies wired, tested and aligned at the factory make Collins Pre-Fab Kits easy to assemble even without technical knowledge. The end result is a fine, high quality, high fidelity instrument at often less than half the cost—because you helped make it AND BOUGHT IT DIRECT FROM THE FACTORY.

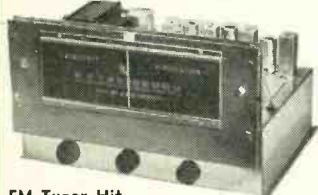

FM Tuner Hit

IF amplifier mounted in the chassis, wired and tested by us. You mount completed RF tuning unit and power supply. After simple wiring, it's ready to operate. 11 tubes. Sensitivity 6 to 10 microvolts with 30 DB quieting. 20 to 20,000 cycle response, AFC, less than 1% distortion. Size: 12½" wide, 9" deep, 7" high, illustrated manual supplied. Shipping weight: 14 pounds. **\$58.50**



FM-AM Tuner Kit

15 tube tuner supplied with AM unit, RF tuning unit with AFC and 10.7 MC IF amplifier as separate, complete sub-assemblies wired and tested, ready for insertion in the punched chassis. Kit includes everything necessary to put into operation; complete chassis kit with power supply and hardware. Size: 14" wide, 12" deep, 7½" high. Shipping weight: 19 pounds. **\$81**

FM-3 Tuning Unit

Permeability tuned, 3 tubes, AFC, 6 to 10 microvolts sensitivity. May be used with any 10.7 MC IF amplifier such as our IF-6. **\$18.75**
2 pounds

AM-4 Tuning Unit

3-gang tuning condenser. Unit covers 530 to 1600 KC. Completely wired and tested with tubes. 4 tubes. Chassis plate measures: 4" x 7¾", 2½" high. **\$24.50**
pounds

IF-6 Amplifier

6 tubes, 10.7 MC. Low distortion, high gain. 3 pounds. **\$21.50**

MAIL COUPON TODAY!

To: Collins Audio Products Co., Inc.
P. O. Box 368 RE-4
Westfield, N. J.
Tel. Westfield 2-4390

FM Tuner Kit FM-AM Tuner Kit
 FMF-3 Tuning Unit IF-6 Amplifier
 AM-4 Tuning Unit

Name _____

Address _____

City _____ State _____

Amount for Kit \$ _____

See weights, add shipping cost \$ _____

Total amount enclosed \$ _____

Check Money Order

WHEN YOU THINK OF TUNERS,
THINK OF
COLLINS AUDIO PRODUCTS

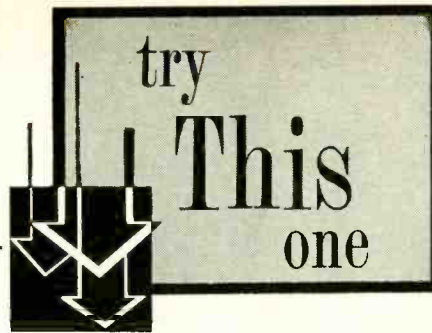

PEAKING SHORTWAVE SETS

Many all-wave sets do not track well on the 6-18- and 18-30-mc bands because of the high ratio of capacitance to inductance. This reduces the sensitivity on the low end.

One way of keeping sensitivity up

high end of a critical band.

To touch up the alignment, tune in a signal at the low end of the band and peak it with the new capacitor. Now open the switch and adjust the high end according to manufacturer's

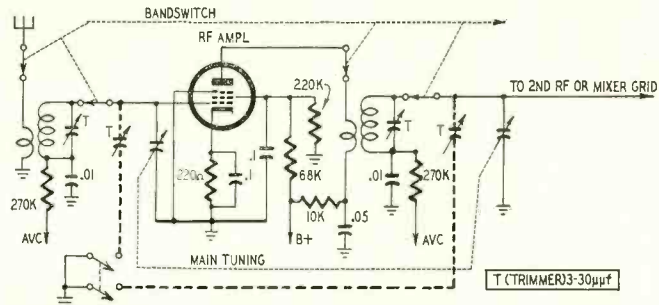

without major alterations is to connect 3-30- μ f variable trimmers across the antenna and r.f. coils through a switch as shown in the diagram. The switch should be opened so it won't degrade performance when listening on the

instructions. This procedure, first applied to a Philco 645, has improved performance of communications receivers with amateur bands on the high and low ends of the tuning range.—
G. P. Oberto

CONVERTER OUTPUT CIRCUIT

When constructing mobile shortwave receiving equipment, low-impedance link coupling is often used between the output of the tuner or a converter and the input to an i.f. channel on another chassis. However, it is often better to use a cathode follower as shown in the diagram. Here the usual converter output transformer is replaced by an

2. This i.f. transformer is completely isolated from the cable so cable length and characteristics are not critical in any respect.

3. More efficient signal transfer is obtained.

4. The first i.f. stage has its input and output transformers completely isolated so there is practically no way

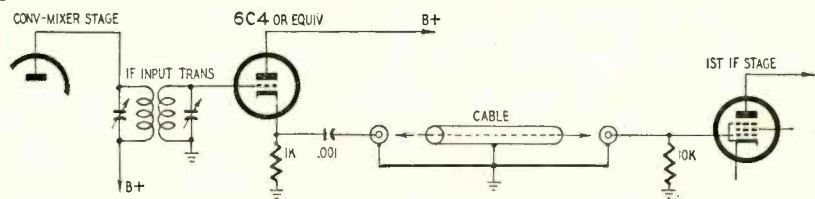

i.f. input transformer and a 6C4 or similar triode is mounted on the converter chassis to feed the cable. The input to the first i.f. stage is not tuned.

This system has several advantages over link coupling:

1. Only one i.f. transformer is required as compared to two for link coupling.

for it to oscillate. Therefore, this stage can be run at higher gain than is otherwise possible, and we can easily overcome the losses in the cathode follower.

5. The components are standard, inexpensive and easy to obtain. The circuit is simple and completely noncritical.—
Charles Erwin Cohn

TEST OSCILLATOR

While trying to find a substitute for the 6J5 cathode follower in the test oscillator in the June, 1953, issue (see diagram) I noticed that some triodes provide greater isolation between the oscillator and load than others. For example, when a 6SF5 is used the

oscillator frequency shifts nearly 2 kc as the output control is varied through its range.

Greater stability with a greater number of tube types giving satisfactory performance as cathode followers is obtained by substituting R-C cou-

TRY THIS ONE

(Continued)

pling between the oscillator plate and the cathode-follower grid. Too, R-C coupling gives a slightly higher percentage of modulation. I found 250 μf

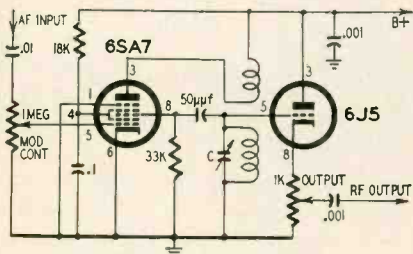

and 1 megohm about right. Most convenient values can be used as long as the capacitance is kept fairly small.

With a broadcast antenna coil and 365- μf tuning capacitor in the circuit the generator produces useful harmonics up to 144 mc.—Richard G. Strippel

I.F. WAVE TRAPS

Miniature i.f. transformers (approximately $\frac{3}{4}$ inch square and 2 inches high) used in small AM, FM and personal portable radios used as unob-

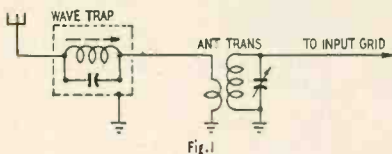

Fig. 1

trusive shielded wavetraps for interfering signals in the i.f. range of receivers.

If the set uses a hank or outdoor

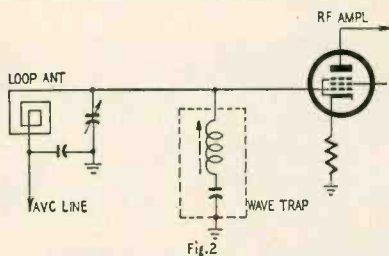

Fig. 2

antenna, connect one of the parallel-tuned coils in series with the antenna lead-in as in Fig. 1. If the set has a loop or Ferrite rod antenna, disconnect the padder capacitor from one end of one of the transformer windings and use the assembly as a series-resonant trap between the grid terminal of the loop antenna and ground as in Fig. 2. Tune the coil for minimum interference.—B. W. Welz

MAKING SMALL CHASSIS

Old aluminum transcription discs provided excellent material for making small chassis and panels but I've not been able to do a good job of removing the coating. Discs that have one blank ungrooved side can be used to make panels that have a handsome glossy black finish.

The plastic coating has a tendency to crack and peel along bends and cut edges but this can be prevented by applying a little service solvent to these portions.—Van H. Ferguson END

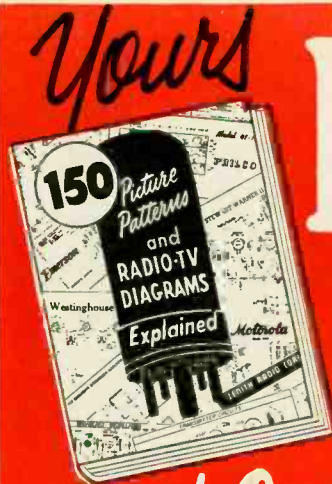

FREE!

This Big Valuable Book Given
Just For Examining
Coyne's New 6-Volume Set

"Applied Practical Radio Television"

ON 7 DAY
FREE TRIAL!

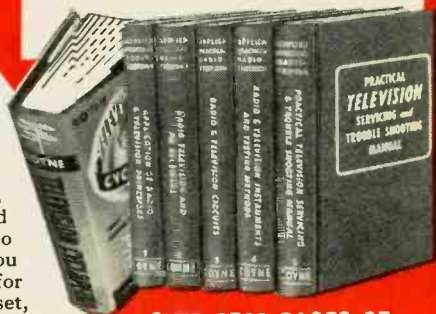

Yes, you get this big, new book, "150 Radio-Television Picture Patterns and Diagrams explained", absolutely FREE! Just off the press! This up-to-the-minute practical book gives complete 11 x 22" Schematic Diagrams on leading models Radio and Television Sets. Easy-to-read, large 8 1/2 x 11" pages, with full instructions on how to read and use the diagrams. A "must" in every Radio and Television serviceman's repair kit. You get this valuable book as a FREE Gift for asking to see Coyne's great new 6-book set, "Applied Practical Radio-Television"!

At Last! Money-Making "Know-How" on Transistors, Color TV and Servicing

Coyne's great new 6-volume set gives you all the answers to servicing problems—quickly! For basic "know-how" that is easy to understand, you'll find everything you want in volumes 1 to 5 which contain over 5000 practical facts and data. They cover every step from principles to installing, servicing, troubleshooting and aligning all types of radio and TV sets. So up-to-date, this set also includes COLOR TV and UHF, adapters, converters. Also covers latest data on TRANSISTORS.

Extra! COYNE's New 900-Page Television Cyclopaedia Included

And then, for speedy on-the-job use, you get Volume 6—the famous Coyne TELEVISION CYCLOPEDIA. It answers today's television problems on servicing, alignment, installation and others. In easy-to-find ABC order, cross indexed. Use this 6-Volume TV-RADIO LIBRARY free for 7 days; get valuable Servicing Book ABSOLUTELY FREE!

SEND NO MONEY!

Just mail coupon for 6-volume set on 7 days free trial. We'll include book of 150 TV-Radio Patterns & Diagrams. If you keep the set, pay \$2 in 7 days and \$2 per month until \$22.50 plus postage is paid. (Cash price \$20.95.) Or you can return the library at our expense in 7 days and owe nothing. YOU BE THE JUDGE. Either way, the book of TV-Radio Patterns is yours FREE to keep! Offer is limited. Act NOW!

OVER 2500 PAGES OF RADIO & TELEVISION FACTS

Vol. 1 — Application of Television-Radio Principles: 300 pages — resonance, tuning, amplifiers, oscillators, etc.

Vol. 2 — Radio, Television & FM Receivers: 403 pages—rectifiers, high frequency, short wave, FM, antennas.

Vol. 3 — Radio-Television Circuits: 336 pages—power tubes, decoupling, distortion, proto-tubes, phase inverters, etc.

Vol. 4 — Latest Instruments For Servicing: 343 pages—all types of testing instruments; their use in service work.

Vol. 5 — TV Servicing & Trouble Shooting Manual: 400 pages—servicing of all TV sets, UHF, boosters, color TV printed in 4 colors, transistors, etc.

PLUS TV CYCLOPEDIA

Quick answers to all TV problems in A-B-C order. 900 pages illustrated; hundreds of facts on servicing UHF, transistors, installation, alignment, much more.

FREE BOOK—FREE TRIAL COUPON!

Educational Book Publishing Division
COYNE ELECTRICAL SCHOOL, Dept. 45-T1
500 S. Paulina St., Chicago 12, Ill.

YES! Send 6-volume "Applied Practical Radio-Television" for 7 days FREE TRIAL per your offer. Include TV-Radio Patterns & Diagram Book FREE.

Name Age

Address

City Zone State

Where Employed

Check here if you want library sent COD. You pay postman \$20.95 Plus COD postage on delivery. 7-day money-back guarantee.

COYNE
ELECTRICAL SCHOOL
(Educational Book Publ. Div.)
500 So. Paulina Street
Dept. 45-T1, Chicago 12, Ill.

OXFORD Speakers

Guarantee Quality Sound

Better sound from OXFORD SPEAKERS complete line from 2" to 15" for all replacement needs... ORDER TODAY!

OXFORD ELECTRIC CORPORATION
3911 South Michigan Avenue • Chicago 15, Illinois

EXPORT — ROBUERN AGENCIES, NEW YORK CITY — IN CANADA — ATLAS RADIO CORP. LTD., TORONTO

Business

Merchandising and Promotion
Sprague Products Co., North Adams, Mass., brought out two new ceramic

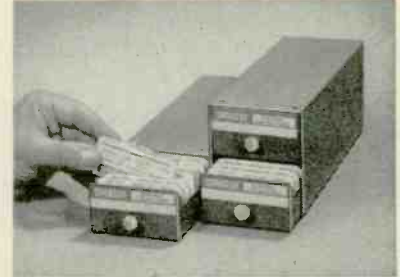

capacitor kits for service technicians and laboratories. The new *Ceramikits* offer the most frequently used capacitors packaged in clear plastic boxes.

They are indexed with standup file separators. Catalog numbers and ratings can be clearly seen.

Quam-Nichols Co., Chicago, Ill., designed for use by its distributors a new envelope stuffer promoting its speakers.

Cornish Wire Co., New York City, is packaging its flat TV lead-in cable in a



counter display carton which holds 10 100-foot coils.

Trio Manufacturing Co., Griggsville, Ill., is marketing its *Aristocrat* rotator control cases under a new plan which enables dealers or distributors to carry a complete stock in all four of the new colors without increasing their inventory. Four cases, each of a different color, are now packaged in one carton.

Vitramon, Inc., Bridgeport, Conn., is packaging its capacitors in a new pack designed for easier shipping and stocking.

John F. Rider Publisher, Inc., New York, is presenting its *Basic Electricity* book sets in a carton which doubles as a counter display.

TELEVISION

Big demand for graduates

B.S. DEGREE IN 27 MONTHS in radio including TV engineering—VHF, UHF, AM and FM. Students use over \$100,000 worth of equipment including 2 large commercial type transmitters in new TV lab. Intense specialized course includes strong basis in mathematics, science and advanced design in radio and TV. Hundreds of young men each year are earning engineering degrees in this recognized institution. Start any quarter. Many earn a major part of expense in this industrial center. Low tuition. Competent instruction. Thorough, intense, practical program. Also **B.S. DEGREE IN 27 MO.** in Aeronautical, Chemical, Civil, Electrical and Mechanical Engineering. G.I. Gov't approved. Enter June, Sept., Dec., March. Free catalog. **ENROLL NOW.**

INDIANA TECHNICAL COLLEGE
1745 E. Washington Blvd., Fort Wayne 2, Indiana

DOUBLE DUTY AC/DC RADIO KIT

with Baby Sitter Attachment

Radio kit includes 5-tube superhet receiver and amplifier in smartly finished custom **WOOD CABINET**. Baby sitter attachment includes switches, complete wiring, 4" speaker.

Comes with full assembly instructions.

Radio kit...\$13.95 Attachments...\$6.95
FUN TO ASSEMBLE—A PLEASURE TO HAVE

CIRCLE ELECTRONICS PRODUCTS COMPANY
39 East 19th Street, New York 3, N. Y.

Allen-Bradley Co., Milwaukee, Wis., is packaging its ½-, 1- and 2-watt fixed

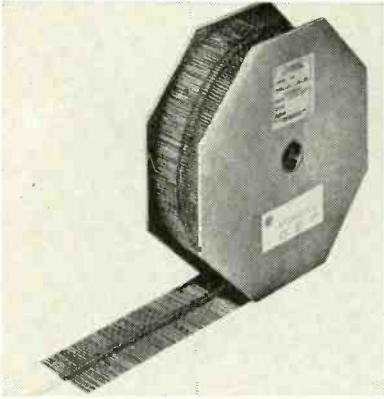

resistors on a novel octagonal 12-inch reel.

Jensen Industries, Forest Park, Ill., is promoting its phono needles with a number of sales aids including the 1955 edition of its needle guide, a new silver-and-black card display, and its phono-needle wall chart.

Jersey Specialty Co., Mountainview, N. J., has launched a nation-wide sales contest to promote its lead-in wire



William and Peter Hagedoorn of Jersey Specialty Co., left, and two friends.

sales. Six grand prizes of trips to Bermuda will be awarded. Contest ends Aug. 10.

Calendar of Events

Fourth Regional Seminar for Parts Distributors, April 1-2, Paxton Hotel, Omaha, Neb.

Spring Assembly Meeting of the Radio Technical Commission for Aeronautics, April 5-7, Los Angeles.

Ninth Annual Spring Technical Conference of the Cincinnati Section of the IRE, April 15-16, Engineering Society of Cincinnati Building, Cincinnati, Ohio.

1955 Electronic Parts Show, May 16-19, Conrad Hilton Hotel, Chicago (closed show for parts distributors and allied personnel).

Production and Sales

RETMA reported that TV production for 1954 reached 7,346,715 units, second only to the record high of 7,463,800 sets in 1950.

RETMA announced that manufacturers had sold 9,913,504 picture tubes during 1954 to establish a new record. In 1954 385,089,458 receiving tubes were sold, compared with 437,091,555 in 1953.

New Plants and Expansions

Sangamo Electric Co., Springfield, Ill., acquired the assets of Gothard Manufacturing Co. in the same city.

WHEN STORMS BREAK LOOSE
PERMA-TUBE STAYS UP
... and so does your reputation!

**J&L
M**

Look for this brand mark
 —only genuine Perma-Tube
 gives you this protection

Here's why . . . sturdy steel PERMA-TUBE is stronger than any other television mast

1. Its resistance to bending is *five times stronger* than structural aluminum.
2. Its resistance to deflection is *three times stronger* than structural aluminum.
3. Its resistance to destruction by wind-force is *twice as strong* as structural aluminum.

ADDITIONAL REASONS FOR USING PERMA-TUBE EVERY TIME

PERMA-TUBE IS CORROSION PROOF . . . it's treated with vinsynite—then coated *inside and outside* with a metallic vinyl resin base.

PERMA-TUBE IS EASILY INSTALLED . . . it's the *only mast* with *both ends* of the joint machine fitted.

ONLY GENUINE PERMA-TUBE GIVES THIS PROTECTION AND SERVICE . . . *look for this brand mark . . . accept no claims from substitute materials.*



For complete information and scientific data write to: Jones & Laughlin Steel Corporation, Department 496, 3 Gateway Center, Pittsburgh 30, Pa.

Jones & Laughlin

STEEL CORPORATION — Pittsburgh

NOT 40% . . . NOT 50% . . . NOT 60% but . . .
SAVE 70%, 80% and 90% OFF LIST PRICES!

Same day service. All tubes RTMA guaranteed for one full year

STANDARD BRANDS and NATIONAL BRANDS

All tubes individually boxed. We also carry a full line of all special purpose tubes. Send us your requirements.

FREE with each \$25 or more order, 5-Pc. Sylvania Repair Kit. Value \$4.95. Includes: flashlight head, Philips screwdriver, flat head screwdriver, alignment tool and polystyrene case.



SPECIALS:

For a limited time only

1L4 1L5 1L6 1L7 1L8 1L9
 2X2 3B7 3D6 6AL7 12B4 19T8

35¢ | **59¢**

FREE: All new customers will receive free as our introductory offer, combination kit of resistors, condensers, volume control and line cords—retail value \$2.95. (May be purchased separately, if desired.)

TERMS: 25% deposit required on all orders, balance COD. Orders under \$5.00, 50c service charge. Postage paid in USA on all orders accompanied by full remittance. All unused money refunded with order.

Our tubes come from such surplus sources as gov't agencies, receiver mfgs., etc. Most are new, balance from gov't and other equipment. ALL TUBES RTMA GUARANTEED FOR ONE YEAR!

0A2	.70	5X4G	.44	6K6GT	.39	12J5GT	.40
0A4G	.60	5Y3GT	.32	6K7	.40	12K8	.49
0B2	.70	5Y4G	.30	6K8	.63	12SA7	.48
0C3	.90	5Z3	.42	6L6GA	.70	12SH7	.47
0D3	.90	5Z4	.54	6L7	.44	12SJ7GT	.45
0Z4	.45	6A7	.59	6N7	.61	12SK7	.48
1A4	.45	6A8	.59	6Q7	.45	12SL7GT	.59
1A7GT	.45	6B4	.44	6R7	.49	12SN7GT	.57
1B3GT	.68	6C7	.70	6S4	.41	12SQ7GT	.40
1C5GT	.43	6A4	.80	6T7G	.47	12T3	.25
1D5GP	.45	6A5	.51	6S47GT	.48	14A5	.59
1E7GT	.43	6A7	.70	6S7	.50	14A7	.45
1G6GT	.43	6A8	.70	6S7	.43	14B6	.40
1H4G	.43	6A15	.70	6SH7	.45	14Q7	.52
1H5GT	.49	6A15	.55	6S17GT	.45	19B6G61	.18
1J6GT	.49	6A15	.40	6SK7	.48	19J6	.66
1L4	.43	6A15	.40	6SL7GT	.57	19T8	.70
1L6	.59	6A55	.50	6SN7GT	.57	24A	.40
1L4A	.59	6A56	1.75	6SQ7GT	.43	25A7GT1	.50
1L6A	.49	6A57G	2.25	6S7	.43	25AV5GT	.80
1L8A	.59	6A76	.40	6S7	.43	25BQ6GT	.80
1LCS	.51	6AU5GT	.60	6T7G	.63	25L6GT	.48
1L6G	.49	6A76	.40	6T7G	.63	25L5	.45
1LD5	.59	6AV5GT	.75	6V6GT	.48	25Z5	.38
1LE3	.59	6AV6	.40	6W4GT	.40	25Z6GT	.38
1LCS	.59	6AK5GT	.59	6W6GT	.56	27	.23
1LH4	.66	6B4G	.54	6X4	.35	32L7GT	.60
1LN5	.49	6B8	.70	6X5GT	.35	35A5	.48
1N5GT	.51	6B8A	.49	6Y6G	.57	35B5	.52
1P5GT	.50	6B8C	.49	6X8	.75	35C5	.51
1R4	.66	6B8E	.50	7A4-XXL	.47	35L6GT	.48
1R5	.57	6B8F	.41	7A5	.55	35W4	.35
1S4	.53	6B8G	1.18	7A6	.47	35Y4	.35
1S5	.52	6B8H	.51	7A7	.45	35Z3	.41
1T4	.58	6B8J	.49	7A8	.46	50L6GT	.45
1T5GT	.58	6B8K	.70	7B5	.41	45Z5GT	.40
1U4	.49	6B8L	.78	7B7	.43	50A5	.48
1U5	.50	6B8M	.59	7B8	.47	50B5	.52
1V	.43	6B17GT	.77	7C4	.40	50C5	.51
1X2A	.63	6BQ6GT	.80	7C5	.44	50L6GT	.45
2A5	.59	6BQ7A	.80	7C6	.45	70L7GT	.60
2A7	.23	6C7	.90	7E5	.35	75	.44
2B7	.89	6B8V5G	.60	7F8	.70	77	.39
2D21	1.00	6C4	.39	7Y4	.35	78	.39
2V3G	.80	6C5	.36	12A6	.40	80	.35
2X2A	1.00	6C6	.51	12AT6	.42	83V	.60
3A4	.53	6C6P6	1.18	12AT7	.68	117L7GT	1.10
3B7	.57	6D6	.50	12AU6	.43	117N7GT	1.10
3D6	.45	6E5	.46	12AU7	.55	117P7GT	1.10
3LF4	.66	6F5GT	.39	12AV6	.37	117Z6GT	.65
3Q4	.48	6F6	.40	12AV7	.69	117Z6GT	.65
3Q5GT	.59	6G6G	.42	12AX7	.60	117Z3	.37
3S4	.48	6H6GT	.40	12B7	.90	117Z6GT	.65
3V4	.58	6J4	2.00	12BA6	.48	2050	1.25
SR4G	.75	6J5GT	.40	12B4	.70	2051	1.25
ST1	.70	6J6	.49	12BE6	.50	9001	1.50
SV4	.44	6J7	.45	12BH7	.61		
5V4	.60	6J8G	.90	12BY7	.68		

Stanley ELECTRONICS CORP.

935 MAIN AVENUE - PASSAIC, N. J.

SEND FOR COMPLETE TUBE LISTING

BUSINESS

(Continued)

The latter company now operates as Sangamo Generators Inc.

Ward Products Corp., Cleveland, Ohio, moved its Sales Department to its plant in Ashtabula, Ohio, under the same roof as the Engineering and Production Departments.

Raytheon Manufacturing Co., Waltham, Mass., is ahead of schedule in beginning the second stage of construction on its new electronics engineering and research laboratory at Wayland, Mass.

Western Electronics Institute, Hollywood, Calif., has completely modernized its shops and classrooms, following the RETMA recommendations as a guide.

CBS-Hytron, Danvers, Mass., established warehousing facilities for its TV picture tubes in Dallas, Tex., to serve the Southwest area.

Sylvania Electric has begun operations in the TV picture-tube plant in Hatboro, Pa., which it took over from National Union Electric Corp. David K. Elwell, formerly of the Seneca Falls plant, is now plant manager at Hatboro. Sylvania announced that practically all the National Union personnel have been retained. The company also announced that it had established an Electronic Systems Division with headquarters in Buffalo, N. Y., and laboratories in Mountain View, Calif., and Boston, Mass. Henry Lehne was appointed general manager of the new division. He was formerly director of Sylvania's Electronic Defense Laboratory in Mountain View, Calif.

Blonder-Tongue Laboratories, Westfield, N. J., opened an additional plant in Newark, N. J.

General Instrument Corp., Elizabeth, N. J., is building a new \$1,500,000 radio-TV-electronic components plant in Statesboro, Ga., believed to be the industry's first major Southern plant.

Trav-Ler Radio Corp., Chicago, purchased the stock of Hallicrafters' Canadian subsidiary, Hallicrafters Canada, Ltd.

Gudeman Co., Chicago, moved its Sunnyvale, Calif., plant to a new larger building.

Superex Electronics moved its offices and factory to larger quarters in Yonkers, N. Y.

Recoton Corp. is now located in Long Island City, N. Y.

Thompson Products, Cleveland, Ohio, announced plans to build a \$5,000,000 engineering study center in Euclid, Ohio.

Business Briefs

. . . RCA developed a new "automated" production machine for effecting time and cost savings in the manufacture of printed-circuit panels. The device is being made available to the entire industry.

. . . Winegard Co., Burlington, Iowa, was assigned a patent covering several antenna constructions including its *Interceptor* antenna and *Electro-Lens* system.

. . . Decision, Inc., Cincinnati, Ohio, published a new *Engineers Job Direc-*

LEARN

Television-Radio Electricity

REFRIGERATION-ELECTRONICS

IN THE GREAT SHOPS OF **COYNE**

TRAIN QUICKLY! OLDEST, BEST EQUIPPED SCHOOL of ITS KIND in U.S.

Come to the Great Shops of Coyne in Chicago. Get practical training in opportunity fields—TELEVISION-RADIO—ELECTRICITY—ELECTRONICS—vital in Defense Program. Prepare now for a better job in Industry or better service rating.

Approved for Veterans
 Finance Plan—Enroll now, pay most of tuition later. If you need part-time work to help out with living expenses while at Coyne, we'll help you get it. Special tuition plan for men of Draft Age.

FREE BOOK Clip coupon for Big Free Illustrated Book. No salesman will call. Act NOW.

B. W. Cooke, President
COYNE SCHOOL
 A TECHNICAL TRADE INSTITUTE CHARTERED NOT FOR PROFIT Established 1899
 500 S. Paulina, Chicago

RADIO ★ REFRIGERATION ★ ELECTRONICS

B. W. COOKE, Pres.
 COYNE School
 500 S. Paulina St., Chicago 12, Ill. Dept. 45-81H

Send FREE BOOK and full details on:
 TELEVISION-RADIO ELECTRICITY

NAME.....
 ADDRESS.....
 CITY..... STATE.....

"Bless these smugglers!"
JENSEN NEEDLES."

BUSINESS

(Continued)

tory designed to aid engineers in finding the right position by giving key facts about leading companies.

... RCA and General Electric have returned to 1-year warranties on TV picture tubes. Several other companies have followed suit.

... Daystrom, Inc., Elizabeth, N. J., now has a majority stock interest in Weston Electrical Instrument, Newark, N. J.

... Telrex, Inc., Asbury Park, N. J., received a patent covering its *Clover-V-Beam* TV antenna.

... The 1955 Western Electronic Show and Convention (WESCON) will be held August 24-26 in the San Francisco Civic Auditorium.

... Ram Electronics Sales Co., Irvington, N. Y., completed arrangements with Howard W. Sams & Co., Indianapolis, for listing its TV sweep components in the Sams' Photofact folders.

... The 1955 British National Radio Show will be held at Earls Court, London, August 24-September 3.

... The German Radio, Phone and TV Exhibition will be held in Düsseldorf, August 26-September 4.

... RETMA filed a petition with the FCC requesting a stay in the effective date of the new "type acceptance-type approval" rules for nonbroadcast transmitting equipment. The association suggested that an industry-Government committee be set up to resolve some of the problems of the rules as now written. END

TRANS-PACIFIC LINK



Phil Anderson, W7SGN, 13-year-old Portland, Ore., ham at the mike of the 700-watt phone-cw rig that he shares with his 18-year-old brother Lloyd, W7REW. An ardent dx'er and traffic man, Phil devotes most of his operating time to handling traffic to and from GI's overseas. A phone patch permits many servicemen to speak directly to loved ones at home. One such conversation lasted for an hour and ran up a bill of \$100 in long-distance telephone toll charges.

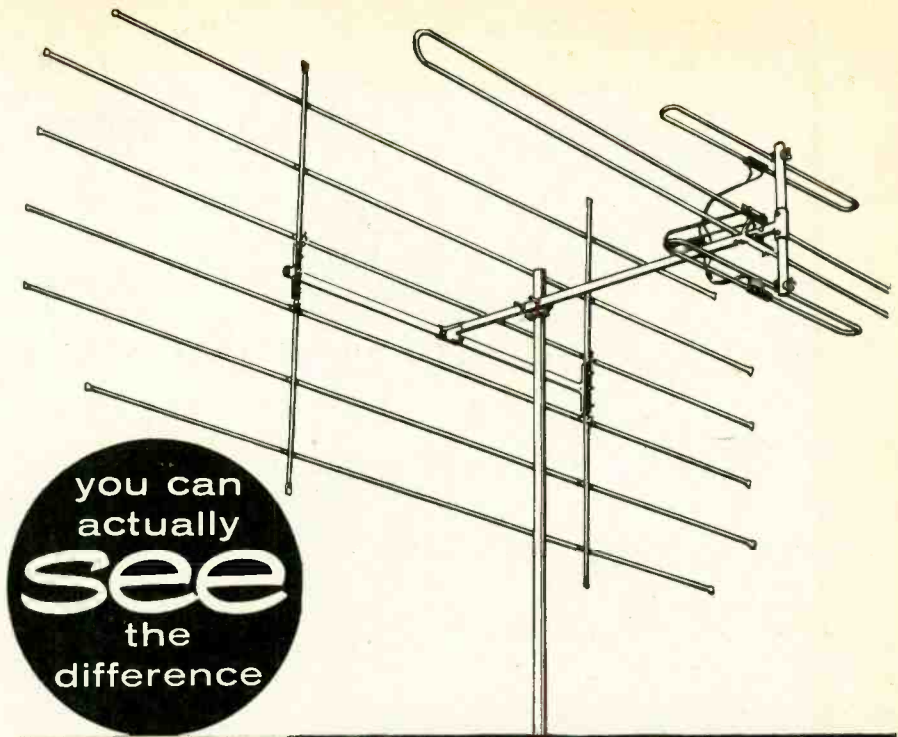

you can actually **see** the difference

with the **C-D Skyhawk ULTAMATIC** All Channel TV Antenna

NOW... C-D designs the finest TV Antenna... the first antenna with which you can actually SEE the difference! Perfectly synchronized for monochrome and COLOR TV. The most uniform gain response that does not vary more than 3 D.B. on any channel across the band. Other features include low voltage standing wave ratio... higher front-to-back ratio... speedy assembly... aluminum screen reflector... dipole and boom of heavy gauge, seamless tubing.



Consistently Dependable
CORNELL-DUBILIER
SOUTH PLAINFIELD, N. J.



CAPACITORS - ANTENNAS - ROTORS - VIBRATORS - CONVERTERS

NEW! WRIST RADIO



Amazingly powerful! Plays while you wear it. 400 mile reception using just its own antenna. Tunes entire broadcast band with sharp selectivity.
BUILD YOUR OWN-New book has complete instructions. How-to-do-it book \$1.98 ppd. Also a basic kit consisting of attractive pre-drilled case, "outline" chassis and all the necessary non-electronic parts and hardware \$2.98 ppd. Combination of book and basic kit, SPECIAL \$3.98 postpaid. Money back guarantee.

HUCKERT ELECTRONICS-Box 7400-C, Washington 4, D. C.

RADIO CONTROLLED
Garage Door
Operating Mechanism **\$24.50**
Write for Information
P. E. HAWKINS CO.
631 Prospect Kansas City 24, Mo.

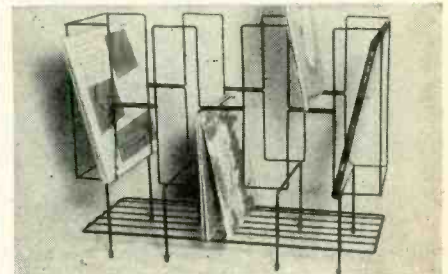

WROUGHT IRON RECORD RACK
Holds 200 long-play records. Also accommodates 78 RPM albums. Black finish with rubber tips to protect your furniture. Size 19 1/2" high, 25" long, 9 1/2" deep. Sturdy construction. Ten separate sections allow for ideal storage of music by style, composer, artist. Several racks may be placed side by side to form a complete library of records. Please remit with order. Satisfaction Guaranteed or Money Refunded. Shipped Express Collect. **\$9.95**
LESLIE CREATIONS • 2116 Robbins St. • Dept. 229 • Phila. 49, Pa

LEARN COLOR UHF, MONOCHROME TELEVISION



Edward M. Noll

nationally known TV consultant, teacher and writer

MAKES IT EASY

in the new revised edition of his famous **TELEVISION for RADIOMEN**

Complete course in one volume

All in one book—at much less cost than the average course of lessons—you'll get **THOROUGH**, practical training for the best jobs in TV. You'll know the fundamentals of both transmission and receiving; the practical techniques of installation, alignment, adjustment, trouble-shooting; the latest improvements, transistor circuits, UHF, color.

You'll **UNDERSTAND TV**; be able to handle service work expertly, efficiently; be well qualified for the hundreds of high-paid technical openings in TV today.

Easy to learn

Each step in theory is explained in clear non-mathematical terms and is applied to circuit set-up and operation so you see exactly how to use theory in practical work. Many schematics and how-to-do-it examples help you learn both theory and practical techniques easily and thoroughly. Study questions insure your understanding.

Prepares you fully for work on color TV, UHF

You'll learn each detail of the NTSC color system; the function of each circuit, the special installation and adjustment techniques, the service problems and how to handle them. You'll know the principles and all practical details of the intercarrier I-F system, the best antenna installations for UHF.

There is no better, more up-to-date, or more thorough book on television fundamentals.

HERE is your ticket to the best TV technical jobs today!

STUDY IT FREE
for ten days
Use this coupon



THE MACMILLAN CO., RE-6
60 Fifth Avenue, New York 11, N. Y.

Please send me a copy of Noll's *Television for Radiomen, Revised*. I will either remit the full price of \$10.00 plus a few cents delivery charge, or return the book in ten days. (SAVE: Send check or money order and we pay delivery charge.)

Signed

Address

This offer good only within continental limits of U.S.A.

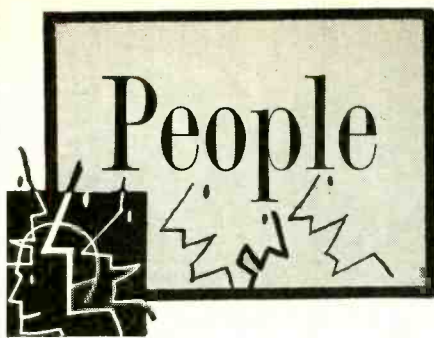

G. Barron Mallory was elected a director of P. R. Mallory Inc., Indianapolis, to fill the vacancy created by the death of Richard C. Hunt. Frank B. Powers,



F. B. Powers



G. M. Arisman

former vice president in charge of manufacturing, was appointed operating vice president of the company and George M. Arisman, Jr. was elected controller.

Hugo Cohn, executive vice president of Radio Receptor Co. Inc., New York, was elected president of the company, succeeding Ludwig Arnson who is retiring as president but remaining as a director and consultant. Harold R. Zeamans was appointed secretary-treasurer of the company.



Physics Laboratories.

Dr. Rudolf G. E. Hutter was appointed manager of the Physics Laboratory of Sylvania Electric Products, Bayside, N. Y. He formerly managed the Physical Electronics Branch of the

David W. Potter, formerly product line manager of semi-conductors, was named sales manager of the Components Division of Federal Telephone and Radio Co., Clifton, N. J.



Howard S. Orcutt joined Pyramid Electric Co., North Bergen, N. J., as chief engineer of the Rectifier Division. He came to Pyramid from Federal Telephone & Radio Co.



TU-SET COUPLER



Engineered to operate two TV sets with a minimum of losses and a maximum signal to each set. Completely isolates the two sets inductively using bifilar type coils. Housed in tough, durable plastic cabinet for outdoors or indoors. Complete with mounting bracket for mast or antenna.

MODEL 54-01
SEE YOUR NEAREST DEALER OR WRITE . . .

EBY SALES CO. OF N. Y.
130 E. Lafayette St., N.Y.C. 13

BUY DIRECT MANUFACTURER TO DEALER
ANTENNAS-INSTALLATION
HARDWARE AND ACCESSORIES
WRITE FOR CATALOG

Skysweeper inc.
P. O. BOX 68
McHENRY, ILL.

When answering advertisements please mention **RADIO-ELECTRONICS**

FREE ALLIED'S SPECIAL 64-PAGE HI-FI CATALOG

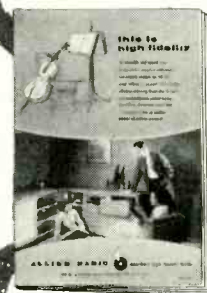

Your guide to an easy understanding of **Hi-Fi**—plus the world's largest selection of **Hi-Fi** systems and components

send for it

This 64-page book shows you how to select a Hi-Fi music system at lowest cost. Tells you what to look for in each unit and shows many handsome, practical installation ideas. Offers you the world's largest selection of complete systems and individual units from which to make your money-saving choice. To understand Hi-Fi, to own the best for less, you'll want this Free book. Write for it today.

ALLIED RADIO

America's Hi-Fi Center

ALLIED RADIO CORP., Dept. C-45
100 N. Western Ave., Chicago 80, Ill.

Send FREE High Fidelity Catalog

Name

Address

City..... Zone..... State.....

PEOPLE

(Continued)

Dr. A. Melvin Skellett has been named director of color television tube planning and development for Tung-Sol Electric, Newark, N. J. Dr. Skellett has been active in research and administrative capacities in the electronics industry for the past 25 years. He holds over 70 major patents in electronics.



Floyd Reid has been named a development engineer of ORRadio Industries, Opelika, Ala. His career in electronics goes back almost 30 years. He recently headed his own firm which developed and manufactured a new type of electronic laminating machine. Reid began his career with Atwater Kent in 1927.



Joseph H. Gibbs was promoted to assistant sales manager of Blonder-Tongue Laboratories, Westfield, N. J.



Left to right: Blonder-Tongue's Joe Gibbs, Bernard Coler and Joe Kerner.

Bernard A. Coler joined the firm as a sales engineer. Gibbs has been with the company for over two years. Coler came to Blonder-Tongue from RCA.

Obituaries

H. Ward Zimmer, president of Sylvania Electric Products and a pioneer in the electrical electronics industry, died recently in New York City after a brief illness.

Charles J. Pannill, a former president of Radiomarine Corp. of America and RCA Institutes and a pioneer in the communications field, died at Harkness Pavilion, New York City, at the age of 75.

Raymond Machlett, founder of Machlett Laboratories, radio and TV transmitting tube manufacturer, died at his home in New Canaan, Conn.

Personnel Notes

... Len Lockwood was appointed national field sales manager of the Winegard Corp., Burlington, Iowa, manufacturer of TV antenna products.

NOW - a complete "Replacement Department" that fits the pocket!

The new
WEBSTER ELECTRIC
Featheride[®]
"Five-Pack" Replacement Kit

Here is the latest idea in the replacement-sales field—an idea that will build added sales and profit for you, plus giving a more complete service to your customers.

Just ask your jobber for the handy new FEATHERIDE "FIVE-PACK" REPLACEMENT KIT—the convenient, pocket-size metal case containing one each of the most popular Featheride Replacement Cartridges: including four fast-selling crystal Featherides and the new MODEL GX ceramic cartridge. This compact assortment meets virtually every replacement need.

Each cartridge comes in its own plastic "jewel case" package; all fittings and full installation instructions are included. Inside cover of case contains replacement data. Case may be hung on wall or displayed on counter.

Contains one each of the following 5 cartridges—

- CX** • May be used with a three-mil needle for 78 RPM or two-mil needle for three-speed application
- AX** • Complete unit for three-speed application, furnished with a removable twist mechanism
- WX** • Lightweight, single-needle, dual-voltage cartridge for 78 RPM or 3-speed use
- GX** • Single-needle, weather-defying ceramic cartridge for 33 1/3 and 45 RPM use
- FX** • Two-needle twist cartridge, delivering high or low output

WEBSTER ELECTRIC
 RACINE WISCONSIN

"Where Quality is a Responsibility and Fair Dealing an Obligation"

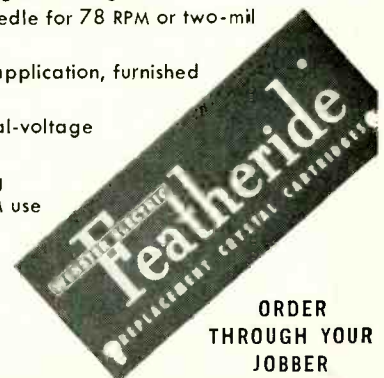

ORDER THROUGH YOUR JOBBER

Which Tube is Bad...

Here's How to Quickly Find Bad Tube in New Series Filament TV Sets



POCKET SIZE—
weighs only 6 oz.

Only checker that automatically checks all tubes!

Also used to check to check Pix tube

IT'S EASY... QUICK and SURE!

Senco

Series Filament TUBE CHECKER

Quick continuity check, no shock hazard. Also voltage indicator when line cord is shorted. No switches or instructions — merely plug in any TV tube, also used for AC-DC RADIOS and PORTABLES.

Carried by leading Jobbers write for Information TODAY!

\$3.95 Dealer's Net

Mfg by **SERVICE** Instruments Company
422 S. Dearborn St • Chicago 5

STAN-BURN E-D-A-R-K-E

CATHODE RAY TUBE SPECIALS

G.E.		STAN-BURN	
10BP4A	\$14.95	10BP4	\$10.20
10FP4A	21.10	12LP4	11.90
12KP4A	24.45	12LP4	13.95
12LP4A	18.75	12QP4	11.90
12QP4A/B1014	25.10	12JP4	11.90
12PP4B	34.25	12P4A	14.50
14CPA	22.50	15DP4	17.50
15DP4/B1014	26.75	16KP4	17.50
Dumont	34.25	16DP4 or A	17.50
16AP4A (N.U.)	25.25	16JP4 or A	17.50
16P4 or B	33.25	16P4A	17.50
16KP4/16RP4	24.20	16WP4	17.50
16KP4A (Aluminum)	28.35	16P4A	17.50
16JP4A (N.U.)	27.95	16P4A	23.00
16LP4A	28.50	16P4A	19.00
16WPA	26.50	16P4A or A	23.50
16GP4B	27.50	16P4A	21.00
17BP4A	33.95	17P4A	18.50
17P4B	29.75	17CP4A	24.50
17CP4	29.95	17GP4B	22.60
17CP4B (Aluminum)	38.50	19P4A	23.00
19AP4A	39.75	19P4A	23.90
20CP4	30.00	19AP4A	24.90
20LP4	37.50	20CP4	23.95
21AP4	37.75	21P4A	25.50
21EP4	32.80	21EP4	26.50
21EP4A	37.35	24AP4	49.00
24AP4	89.75		

PRICES SUBJECT TO CHANGE WITHOUT NOTICE

AUTHORIZED DISTRIBUTORS for: General Electric, Kenrad, Tung-Sol, National Union, De Wald, Regal, Automatic and General Motors.

AUTOMATIC CUSTOM-BUILT RADIOS for Plymouth, Ford, Chevrolet and many others, always in stock. We carry a complete stock of HI-FIDELITY and SOUND EQUIPMENT. Send us your requests. We also carry a complete line of popular makes of Radio tubes at 50/10% discount. Also many other special purpose and transmitting types and all electronic parts and equipment at lowest prices. Send us a list of your requirements for prompt quotations. Terms: 20% with order. Balance C.O.D. All prices FOB. NEW YORK Warehouse. Minimum order \$5.00. Write for our latest price list and Hi-Fi Catalog to Dept. RE-4.

STAN-BURN RADIO and ELECTRONICS CO.
1697 BROADWAY • NEW YORK 19, N.Y.

... F. P. Rice, formerly manager of the cathode-ray tube division, was appointed to the newly created position of director of manufacturing and purchasing for Allen B. Du Mont Laboratories, Clifton, N. J.

... Rayford E. Nugent was named general sales manager of the Philco Parts and Accessories Division, Philadelphia. He was formerly division manager of the Southeast Division. William J. Horn, previously in charge of air conditioning and electric range advertising of Philco's Appliance Division, was promoted to merchandising and advertising manager for the Parts and Accessories Division, filling the vacancy created by the death of Robert N. McKinney some months ago.

... Brig. Gen. Peter C. Sandretto and A. G. Clavier were appointed assistant vice-presidents of Federal Telecommunication Laboratories, Nutley, N. J. Both were formerly technical directors of the company.

... Stanley A. Baum, auditor for Allied Radio Corp., Chicago, for the past two years, was named comptroller of the company. Goodwin G. Mills, formerly a captain in the U. S. Army Research Group, joined Allied as manager of the Electronic Kit Dept. Leonard S. Preskill was appointed product development manager of the company. He previously handled mailing lists research.

... Doug Carpenter, chief antenna engineer for JFD Manufacturing Co., Brooklyn, N. Y., has been selected by RETMA to head a committee to rewrite Article 810 of the National Electric Code which deals with installation techniques for transmitting and receiving TV antennas, accessories and masting and amateur radio transmitting and receiving systems.

... Norma L. Testardi was appointed advertising manager of International Resistance Co., Philadelphia. She has been active in the field of television and served as publicity director for the American Philatelic Congress.

... R. S. Fenton, formerly vice president and general sales manager of Permoflux Corp., Chicago, has assumed the duties of vice president in charge of sales and engineering in an expansion of the company's management structure. Other appointments include Frank Newberg, manager of manufacturing; Edward Watermulder, administrative manager; Sam Hyman, chief commercial engineer; Walter Padgett, chief engineer. G. W. Adams continues as superintendent and M. F. Heineman as secretary-treasurer.

... William Dubilier, founder of Cornell-Dubilier Electric Co., South Plainfield, N. J., was selected by the Alumni Association of Cooper Union to receive the first annual Gano Dunn Medal to be awarded every year to an alumnus for outstanding professional achievement. ... B. B. Bauer, vice president of Shure Brothers, Chicago, was elected a Fellow of the Audio Engineering Society.

6-VOLT BATTERY SOLDERING IRON AND WELDER

U.S. Army release. Brand New—Never Used. Fully Guaranteed. This soldering iron can be used to solder or weld when connected to any six-volt storage battery. Uses approximately 200 to 300 watts. The high intensity arc created between the metal to be soldered and the carbon electrode (carbons supplied free with iron) can be used to heat tin or aluminum solder. Suitable also for light brazing and spot welding. Arc can be used

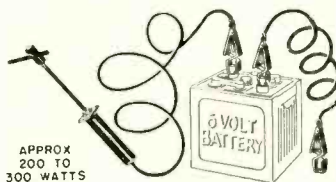

APPROX 200 TO 300 WATTS

for melting metals, cutting holes and soldering seams in chassis. Also useful for analyzing metals and minerals. Battery soldering iron outfit includes 2 carbons, 3 heavy duty spring clips, 2 pieces 5 ft. heavy duty wire cable. (Battery not included.) Ideal for use where current is not available. Ship wt. 4 lbs.

ITEM NO. 126 UNUSUAL BUY (P.P. & Hdq. Chgs. 50c) **\$1.95**

WESTERN ELECTRIC BREAST MIKE

Lightweight carbon microphone. Breastplate mounting, adjustable 2-way swivel. For home broadcasts, communications, etc.

Ship. wt. 2 lbs. **\$1.98**
ITEM NO. 152
NEW LOW PRICE (P.P. & Hdq. Chgs. 32c)



WATTHOUR METER



Leading makes — reconditioned. Ideal for trailer parks. 100-110 volts, 60 cycles, 2-wire A.C. 5 amp. Heavy metal case 8 1/2" x 6 1/4" x 5". Easy to install. Ship. wt. 14 lbs. **\$4.50**
(P.P. & Hdq. Chgs. \$1.25) ITEM NO. 33

AMAZING BLACK LIGHT

250-watt ultra-violet light source. Makes fluorescent articles glow in the dark. Fits any lamp socket. For experimenting, entertaining, unusual lighting effects.

Ship. wt. 2 lbs. **\$2.45**
ITEM NO. 87
(P.P. & Hdq. Chgs. 35c)



BLAK-RAY SELF-FILTERING ULTRA-VIOLET LAMP

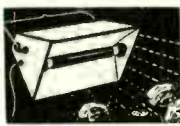

BLAK-RAY 4-watt lamp, model X-4, with U-V tube. Lamp has a wave-length of 3654 to 4000 angstrom units. Some of the substances made to fluoresce are certain woods, oils, minerals, milkstone, cloth, paints, plastics, yarn, drugs, crayons, etc. Self-filtering and harmless. Equipped with aluminum reflector. 110 volt 50-60 cycle A.C. 2000 to 3000 hours of service. Approved by Underwriters has a built-in transformer. **\$16.75**
ITEM NO. 125 (Shp. Chgs. 70c)

POWERFUL ALL PURPOSE MOTOR

Sturdy shaded pole A.C. induction motor. 15 watts, 3000 rpm. 3"x2"x1 3/4"; 4 mounting studs; 7/8" shaft, 3/16" diameter; 110-120 volts, 50-60 cycles. A.C. only. ITEM NO. 147 **\$2.45**
UNUSUAL BUY (P.P. & Hdq. Chgs. 35c)



250 POWER TELESCOPE LENS KIT

Make your own high powered 6 ft. telescope! Kit contains 2" diam., 75" focal length, ground and polished objective lens and necessary eye pieces. Magnifies 50x to 250x. Full instructions. ITEM NO. 123 **\$2.95**
(Shp. Chgs. 10c)



HUDSON SPECIALTIES CO. 25 West Broadway, Dept. RE-4-55 New York 7, N. Y.

I am enclosing full remittance for items ordered below. (Be sure to include shipping charges.)
OR, my deposit of \$..... Ship balance C.O.D. MINIMUM C.O.D. ORDER \$5.00.
C.O.D. ORDERS ACCEPTED ONLY WITH 20% DEPOSIT INCLUDE SHIPPING CHARGES.

Circle Items Wanted
87 147 33 152 126 123 125

Name
Please Print Clearly
Address
City Zone State

technical Literature

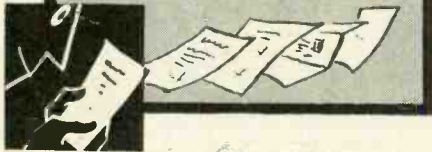

AUTO RADIO TRANSFORMERS

Stancor's 8-page *Auto-Radio Replacement Guide No. 500* lists both vibrator-power and audio-output replacements for over 540 car radios. It includes all models used by the major automobile manufacturers as well as private label brands. More than 40 manufacturers are listed and cross-referenced. Information as to the year each model was used is also included. A separate catalog page lists detailed specifications on 25 vibrator power transformers, including 21 exact replacements, and 19 audio outputs used in car radios.

Chicago Standard Transformer Corp., Addison & Elston Sts., Chicago 18, Ill.

TV ANTENNAS

TV antennas and accessories are described and illustrated in RMS' 25-page *Catalog No. 55A*. It is completely indexed, and gives list prices for each item shown.

Radio Merchandise Sales, Inc., 2016 Bronxdale Ave., New York 62, N. Y.

Any or all of these catalogs, bulletins, or periodicals are available to you on request direct to the manufacturers, whose addresses are listed at the end of each item. Use your letter-head—do not use postcards. To facilitate identification, mention the issue and page of RADIO-ELECTRONICS on which the item appears. UNLESS OTHERWISE STATED, ALL ITEMS ARE GRATIS. ALL LITERATURE OFFERS ARE VOID AFTER SIX MONTHS.

HIGH-FIDELITY CATALOG

Allied's 68-page booklet *This Is High Fidelity* contains an illustrated section explaining high fidelity, with comprehensive up-to-date listings of hi-fi music systems and separate components. The functions of the basic units used in home hi-fi music systems are discussed in nontechnical language. Tips on what percentage of the hi-fi dollar to appropriate to each component and on how to save money in the selection and installation of components are also given. Completely illustrated matched hi-fi systems are shown in numbers.

Allied Radio Corp., 100 N. Western Ave., Chicago 80, Ill.

MAGNETIC TAPE

An 8-page booklet No. 190 on *Scotch* magnetic tape discusses playing time, tape strength, reel sizes, recorder settings and performance characteristics of new *Extra Play* magnetic tape.

Minnesota Mining & Mfg. Co., 900 Fauquier St., St. Paul 6, Minn.

MOST POWERFUL TV ANTENNA EVER DEVELOPED FOR HOME USE

Rembrandt
FOR THE FINEST IN PICTURES

MONEY BACK GUARANTEED TO
**ELIMINATE
ROOF ANTENNAS**

IN METROPOLITAN AREAS

UP TO

**10 TIMES
MORE
POWERFUL**

THAN CONVENTIONAL
ANTENNAS

ELIMINATES

**ALL
GHOSTS**

IN PRACTICALLY
ALL LOCATIONS

\$14.95
LIST
COMPLETE

FIVE U.S. PATENTS GRANTED

WRITE • WIRE • PHONE • FOR NAME OF NEAREST DISTRIBUTOR OR DEALER

ALL CHANNEL ANTENNA CORP.

47-39 49th STREET, WOODSIDE 77, N. Y.

EXETER 2-1336

Important Notice to

SUBSCRIBERS

If you're moving, please don't forget to send us your address as it appears on the copy of the magazine, including the numbers shown beside your name, as well as your new address. If possible, send us your address label which is pasted on the upper left hand corner of the back cover.

If we receive this information before the 20th of the month, you will continue getting the magazine without interruption.

Your cooperation will be most helpful and greatly appreciated.

Please send your new address to:

RADIO-ELECTRONICS

Circulation Department

25 W. Broadway, New York 7, N. Y.

Way or LICENSE EXAMS!

ONLY \$5.00
No lessons
to wait for

Train now for
bigger pay in
Radio-Tv's
most
interesting
jobs!

New!

LICENSE MANUAL FOR RADIO OPERATORS

by J. Richard
Johnson

Answers almost
2200 typical
FCC examination
questions

A complete study
guide for getting
your ticket as a
commercial
operator
for good-pay
jobs in

COMMERCIAL RADIO OR TELEVISION STATIONS

SHIP OR MARINE RADIO

AIR LINE RADIO

COMMUNICA- TIONS, etc.

TRAIN EASIER AND FASTER!

Anyone who has basic training as a serviceman, experimenter, amateur or engineer will find LICENSE MANUAL FOR RADIO OPERATORS the ideal training book for making this all-important step in his career.

Whether you'd like to pass the FCC exam for either 1st or 2nd phone or telegraphy license, this big book will guide you ALL the way. A skilled instructor standing by your side could hardly do better!

10-DAY FREE EXAMINATION

Dept. RE-45, Rinehart & Co., Inc.
232 Madison Ave., New York 16, N.Y.

Send Johnson's new LICENSE MANUAL FOR RADIO OPERATORS for 10-day FREE examination. If I decide to keep book I will then promptly send you \$5.00 (plus a few cents postage) in full payment. Otherwise, I will return book postpaid and owe you nothing.

Name

Address

City, Zone, State.....

(OUTSIDE U.S.A.—Price \$5.50 cash with order. Money back if book is returned in 10 days.)

TECHNICAL LITERATURE (Continued)

LOUDSPEAKER

Jensen's *Bulletin No. 1001* describes their new miniature loudspeaker P275-Y. All technical information and specifications are given.

Jensen Mfg. Co., 6601 S. Laramie Ave., Chicago 38, Ill.

RADIO INTERFERENCE FILTERS

A 22-page catalog discusses the *Filtron* type FSR r.f. interference suppression filters for use in screen rooms, induction heating equipment, diathermy and X-ray units or similar equipment. Detailed information on each filter is given by cutaway views, dimension drawings and descriptive text. Graphs of attenuation characteristics and complete engineering data on every unit specify the right filter for any particular application.

One section of the two-color catalog shows accessories, such as filter assembly boxes, waveguide fittings and enclosed safety switches, and discusses installation information and design considerations.

Filtron Co., Inc., Flushing, L. I., N. Y.

AUTOMATION DICTIONARY

This little dictionary covers some 87 words and phrases, all of which originated with engineers but are now creeping into the lexicon of today's businessman. Each word is defined in simple language to enable the non-technical individual to better understand the language engineers speak.

Mr. W. Lang, Brown Instrument Div., Minneapolis-Honeywell Regulator Co., Wayne & Windrim Aves., Philadelphia, Pa.

TRANSISTORIZED WRIST RADIO

A 4-page *Bulletin PB 111461* describes the transistorized wrist radio referred to in our March, 1954, issue (page 82). All technical information as well as a schematic is given.

U. S. Department of Commerce, Office of Technical Services, Washington 25, D. C. 25 cents. END

Radio Thirty-Five Years Ago

In Gernsback Publications

HUGO GERNSBACK Founder

Modern Electrics	1908
Wireless Association of America	1908
Electrical Experimenter	1913
Radio News	1919
Science & Invention	1920
Television	1927
Radio-Craft	1929
Short-Wave Craft	1930
Television News	1931

Some of the larger libraries still have copies of **ELECTRICAL EXPERIMENTER** on file for interested readers.

In April, 1921, *Science and Invention* (formerly *Electrical Experimenter*)

Radio Relayed Over Land Lines
The Audio-Frequency Amplifier in France, by Robert E. Lacault
Radio Transmission Phenomena by Amateur Radio Operators

What Will This New Labor-Saving BAUMKER SERVICE BENCH* Do For You?

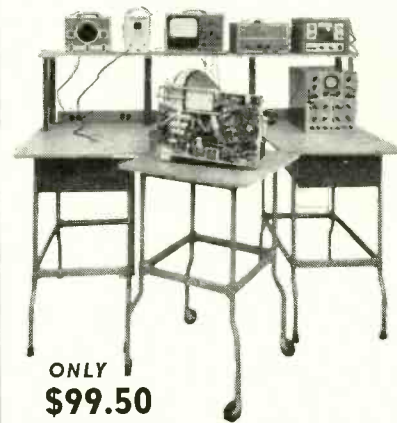

ONLY
\$99.50

f.o.b. Toledo, O.

*Pat. Pending

IT WILL:

- * Save You Money
- * Increase Efficiency
- * Cut Your Costs
- * Stop In-Shop Breakage
- * Cut Chassis Handling
- * Protect Test Equipment
- * Protect Your Men

Many more exclusive advantages you'll quickly recognize when you see this amazing new service bench—designed with the serviceman in mind. For complete information see your Distributor or write

BAUMKER Manufacturing Co.
3873 Summit St. Toledo, Ohio

!! COLOR TELEVISION FILTERS !!

New Tri-Color Filter adds life-like tones to ordinary Black & White Picture

10"	\$1.29	19" 21"	\$2.89
12" 14"	\$1.49	24" 27"	\$3.98
16" 17"	\$1.98		

"A" BATTERY VOLTMETER . . . Pocket type. Tests any dry cell up to 4 1/2 V. . . ea. \$1.29
2" INSTRUMENT SKIRT KNOB . . . Fluted moulded bakelite. 2 1/2" skirt. 1/4" or 3/8" hole—ea. 39c; 6/1.98
0.5 DC MILLIAMMETER (2" round panel) . . . Calib. for recording level output. 1" deep. . . \$2.75

!SPECIAL!—130 WATT HEAVY DUTY "ESICO" SOLDERING IRONS

3/8" adjust. plug-in tip. 6 ft. rubber cord. Reconditioned. Guaranteed perfect. ONLY . . . \$2.95
ACOUSTICAL CELOTEX SPEAKER BAFFLES
1" thick. Specify hole size when ordering.

10" sq—59c	14" sq—89c
12" sq—69c	18" sq—\$1.25

Any size cut to order—50c sq. ft.
Hole Cutting Charge (special sizes only)—50c

!! WHAT A BUY !!

"Jumbo Radio-Electronics Parts Kit"

We clear our shelves of odds & ends of regular & surplus stock! YOU SAVE \$\$\$!

17 LBS.
CHOCK-FULL OF:
COILS, RESISTORS, HARMS, WARE, CAPACITORS, SPEAKERS & ACCESSORIES, PHOTOFACTS, CONTROLS, SWITCHES, WIRE, P.L.U.S. DOZENS OF OTHER ITEMS! (shipped wt. 20 lbs.)
ALL FOR

\$3.95



DUAL FLASHLIGHT BATTERY HOLDER . . . holds 2 "D" cells for Portables, Meters, etc. ea. 29c; 10/2.50
PHONO GOVERNOR WEIGHTS . . . replacement for G.I. Flyer motors. With spring. . . ea. 39c; 6/1.98

SHAFT COUPLINGS & EXTENDERS

COUPLINGS (brass)—	3/4" x 1/2" O.D. . . .
1/4"-1/4", 3/8"-3/8" or 1/2"-3/8"	ea. 15c
3/16"-1/4" or 3/16"-3/8"	ea. 19c
EXTENDERS—	2 1/2" long—1/4"-1/4" ea. 23c; 5/1.00
1/4"-3/16", 3/16"-1/4", 3/8"-1/4", 1/4"-3/8", 3/16"-3/8" or 3/4"-3/16"	ea. 29c; 4/1.00

CRYSTAL MIKE . . . Hi-Impedance, rubber shock mtd. 1 1/2" x 1 1/4" deep. Less housing. . . \$1.29
ALUMINUM HOUSING for crystal mike15
Min. Orders \$3.00—20% Dep. On All C.O.D.'s.

LEOTONE RADIO CORP.
67 Day Street
New York 7, N. Y.

New MagneLoop, Jr.

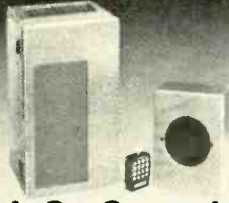

A.C. Operated Magnetic Tape Recorder Message Repeater

Ideal for: Point-of-Sale Advertising ★ Super Markets & Stores ★ Industrial Exhibits Window Displays ★ Hotel Lobbies

Model A records and plays back messages, music or sound effects totalling 10 minutes in duration at 3 3/4 ips. Model B operates at 7 1/2 ips and records material for a period of 5 minutes. Employs a continuous loop cartridge of standard 1/4" wide magnetic tape which runs intermittently or continuously for any length of time without loss of quality or wear. Designed for dependable, permanent trouble-free performance. Easily placed anywhere.

Measures 15 1/2" H. x 7 3/4" D. x 9" W. Weighs only 13 lbs. Furnished complete with microphone tape cartridge, encased 5" loudspeaker and instructions.

Factory Net Price **\$85.00**

Order Direct From Factory

AMPLIFIER CORP. of AMERICA

398 Broadway, N. Y. 13, N. Y.



**NOW
COYNE**
TRAINS YOU
IN SPARETIME
AT HOME

TELEVISION RADIO-ELECTRONICS

Only from famous COYNE do you get this modern up-to-the-minute TV Home Training. Easy to follow Step-by-Step instructions—fully illustrated with 2150 photos and diagrams. Not an old Radio Course with Television tacked on. Personal guidance by Coyne Staff. So practical you can quickly EARN MONEY in a TV-RADIO SALES AND SERVICE BUSINESS—part time or full time. Not only FINEST TRAINING but COSTS MUCH LESS—pay only for training—No costly extras.

SEND COUPON for DETAILS FREE

SEND COUPON BELOW for Picture Folder and full details including EASY PAYMENT PLAN. NO COST OR OBLIGATION—NO SALESMAN WILL CALL.



B. W. COOKE, Pres. **COYNE** FOUNDED 1899
ELECTRICAL SCHOOL

A TECHNICAL TRADE INSTITUTE CHARTERED NOT FOR PROFIT
500 S. Paulina Dept. 45-HT4 Chicago 12, Illinois

B. W. COOKE, President
COYNE ELECTRICAL SCHOOL
500 S. Paulina St., Chicago 12, Ill., Dept. 45-HT4

Send FREE Picture Folder and details of your Television-Radio-Electronics Home Training offer.

Name.....
Address.....
City..... State.....

APRIL, 1955

Books

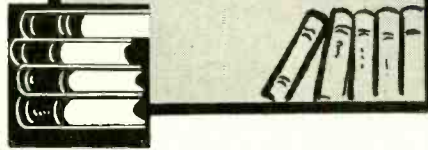

BASIC TELEVISION, PRINCIPLES AND SERVICING (Second Edition), by Bernard Grob. McGraw-Hill Book Co., Inc., 330 W. 42 St., New York, N. Y. 6 x 9 inches, 662 pages. \$6.

Although the title of this book seems to indicate a balance between theory and practice, it is more concerned with an explanation of how television works. This is a job that the book does extremely well. A careful study will supply technicians with a very desirable background of TV theory.

In a very readable fashion, the book covers television transmission and reception, the formation and use of sync and video signals, amplitude and frequency modulation, picture tubes, tuners, a.g.c., antennas, etc. You will also find a rather thorough stage-by-stage analysis of picture receiver circuits. Part of the material that appeared in the first edition, and now out of date, has been deleted. In line with the trend in our industry, the author has added a completely new section on color TV.—MC

ELECTRICAL APPLIANCE SERVICE MANUAL, by William Gabbert. Rinehart & Co., Inc., 232 Madison Ave., New York 16, N. Y. 5 1/2 x 8 1/2 inches, 372 pages. \$5.

Some men, if called service technicians, will take this description quite literally and try to repair everything in sight. Whether you want to be strictly a radio and TV technician or a jack-of-all-electrical-work is mostly a matter for personal choice. If you like to vary the routine of radio and TV repair with odd jobs on electrical appliances, then you'll find this book interesting, helpful, valuable.

Well written and clearly illustrated, the book describes the repair of toasters, irons, hotplates, roasters, sandwich grills, washing machines, vacuum cleaners, electric ranges, electric clocks, water heaters, fluorescent lamps, etc. In other words, practically any home appliance that can be plugged into an outlet (but which should be fixed first) is covered in this book.—MC

THE OSCILLOSCOPE, by George Zwick. Gernsback Publications, Inc., 25 W. Broadway, New York, N. Y. (No. 52, Gernsback Library) 5 1/2 x 8 1/2 inches, 192 pages. \$2.25.

The oscilloscope is the radio-TV service technician's most useful but most complicated instrument. Every technician who uses one should, of course, know all about the scope itself. He should also know how to connect

HELP..

Rider books can help you do more,
learn more, earn more. See for
yourself how much they'll help YOU!

ADVANCED TV SERVICING TECHNIQUES

by the Teaching Staff, RETMA Pilot
Training Course

Complete this course and you'll be able to service any black & white TV receiver! At great cost, the RETMA (Radio-Electronics-Television Manufacturers Ass'n.) developed this fine program, tried and tested every phase with outstanding results! Now—the actual text and lab workbook are available to you! Learn how to service every section of a TV receiver—how to use all types of test equipment! If you'd taken this course at the N.Y. Trade School, you'd have paid \$60. Look at the low, low cost of these books!
Main Text: 176 (8 1/2 x 11") pp., illust., only \$3.60
Lab Workbook: 32 (8 1/2 x 11") pp., only 95¢

OBTAINING & INTERPRETING TEST SCOPE TRACES

by John F. Rider

The "Dean of American Servicemen" discusses the scope trace as it has never been discussed before! Almost 2 years in production, this book is absolutely the last word on explaining what you see on the scope screen! In a clear, non-mathematical approach, the author covers all types of test scope traces—radio, TV, amplifiers, power supplies, generators! This book tells and shows you how to get the most out of your scope! Over 800 illustrations!

CHAPTERS: Sine & complex waveforms—Square waveforms—Rectangular waveforms—Sawtooth & trapezoidal waveforms—Differentiated & integrated waveforms—Amplitude modulated waveforms—Response & S curves—Interpretation of test scope traces—Phase & frequency scope traces—Test set-ups.
192 (5 1/2 x 8 1/2") pp., illust., only \$2.40

FUNDAMENTALS OF TRANSISTORS

by Leonard Krugman, U. S. Signal
Corps Engineering Laboratories

Learn all about the transistor! It's smaller than a jelly bean—it's rugged as they come—and it's the thing in electronics today! With more and more uses for transistors being developed all the time, every service technician, student, engineer, and experimenter must be familiar with transistors—must know their characteristics and operation! Leonard Krugman, who wrote this authoritative book, is one of the pioneers in transistor development and application, and his presentation covers every phase—everything you need to know about this electronic miracle! No complicated mathematics—clearly written so everyone can understand!

CHAPTERS: Basic Semi-conductor physics—Transistors and their operation—The grounded base transistor—Grounded emitter and grounded collector transistors—Transistor amplifiers—Transistor oscillators—Transistor high-frequency and other applications—Appendix—Index.
144 (5 1/2 x 8 1/2") pp., illust., only \$2.70

ORDER TODAY!

These books are sold by electronics parts jobbers and book stores. If YOUR dealer doesn't have these books, mail this coupon!
JOHN F. RIDER PUBLISHER, INC.
480 Canal Street, N.Y.C.

Please RUSH me
 ADVANCED TV SERVICING TECH. \$3.60
 " " " LAB WORKBOOK 95¢
 TEST SCOPE TRACES \$2.40
 FUNDAMENTALS OF TRANSISTORS \$2.70

Name.....
Address.....
City & State.....

SERVICEMEN'S AIDS



2 New
IFS
Exclusives!



FIL-CHECK

The Only Instantaneous
Heater or Filament Checker

- CHECKS ALL TUBES INCLUDING PICTURE TUBE
- NO SETTINGS, NO CONNECTIONS, NO BUTTONS TO PUSH
- OPERATES WITH CHEATER CORD ON ANY LINE—AC or DC
- SAVES TIME AND MONEY IN CHECKING OPEN HEATER IN SERIES-HEATER SETS
- CHECKS ANY CIRCUIT OR APPLIANCE FOR CONTINUITY

\$3.25
Servicemen's Net

ALL-CHECK

Compact
Multi-Purpose Checker

- CHECKS INTER-ELEMENT SHORTS IN ALL TUBES
- CHECKS OPENS, INTERMITTENTS, LEAKAGES OR SHORTS IN PAPER, MICA, OIL & ELECTROLYTIC CONDENSORS
- CHECKS WHETHER VOLTAGE IS AC OR DC (AND POLARITY IF DC) FROM 80 VOLTS TO 660 VOLTS
- CHECKS CIRCUIT CONTINUITY AND COMPARATIVE RESISTANCE TO APPROX. 20 MEGOHMS—FASTER THAN AN OHM-METER

\$14.95
Servicemen's Net

IMMEDIATE DELIVERIES — REG. DISTRIBUTOR DISCOUNTS



Instruments for Service Inc.

96 SOUTH GRAND AVENUE, BALDWIN, LONG ISLAND, N. Y.

SPECIAL CLOSE-OUT



3 SPEED PORTABLE RECORD PLAYER

FAMOUS MAKE 3 Speed Record Player. Plays all speeds, 33, 45, 78 RPM. Complete with powerful amplifier. Housed in fine leatherette covering. Two controls—Tone and Volume. All purpose needle plays 3 speeds.

List Price \$29.95

\$13⁹⁹

Your Cost Only

FREE BARGAIN CATALOG • WRITE DEPT. RE-4

STEVE-EL Electronics Corp.

61 Reade St.

New York 7, N. Y.

ARKAY KITS

WORLD'S FINEST

RADIOS PHONOGRAPHS TV
TEST EQUIPMENT HI-FI

Write for FREE Brochure

RADIO KITS, INC. • 120 Cedar St., N. Y. 6

FREE! REQUEST PORTFOLIO 200
TO EVERY TV SERVICEMAN

GET IT TODAY! TV accessories and parts catalogs, literature, data sheets, etc. Yours for the asking!

Vidaire ELECTRONICS MFG. CORP.
Main Office & Plant
576 WEST MERRICK ROAD LYNBROOK, N. Y.

NOW! Service Dealers can offer the finest in
HI-FI on an investment of only
\$495**

TRANSVISION Lifetime MATCHED HI-FI UNITS enable you to undersell ALL competition at a good profit! You get full Dealer Price Protection—and more!

**How? Rush coupon for full details about our great "Dealer Hi-Fi Program."

FOR
The Finest
MASTER AMPLIFIED
AND **COMMUNITY TV**
ANTENNA SYSTEMS—

— Send Us Your Problem for FREE Engineering Advice.

FREE: Important Technical Manual for Community and Master TV Systems

RUSH THIS COUPON NOW

TRANSVISION, INC., NEW ROCHELLE, N. Y. E-4

Rush details on Hi-Fi Dealer Program;
 FREE Manual for Master Antenna Systems

Name _____
Address _____
City _____ State _____

BOOKS

(Continued)

it to any circuit he is testing and how to interpret the results he sees. This book gives complete, practical information. It is useful to beginners as well as more experienced workers. Diagrams and schematics round out the detailed information.

After describing the cathode-ray tube and its circuits, the author goes into scope applications. He tells how to align radio i.f., FM discriminators, video channels; how to measure frequency and phase difference, etc. Step-by-step information makes the procedures easy to follow.

The last chapter lists various experiments that can be made with a scope. This data can do much to dispel the mystery surrounding an oscilloscope.—IQ

ANALYZING AND TRACING TV CIRCUITS, by Milton S. Kiver. Howard W. Sams & Co., Indianapolis, Ind. 8½ x 11 inches, 145 pages. \$3.

A far cry from Kiver's usual efforts, this book does not fill any particular need in the television field. The text is highly disconnected, jumping from one section of a TV set to another without any apparent continuity. The experienced service technician will find very little of interest, and the inexperienced technician may have difficulty piecing together the various chapters into an effective educational instrument. For the student, the book is entirely inadequate, theory being incomplete.

Individually each of the 10 chapters is well written, but they vary greatly in technical level. Some are extremely simple—things you should know about every circuit and differences between schematics and sets. Then, giving the reader no preparation, Kiver delves deeply in chapters on where the boost voltage fits in and the a.g.c. system. The appendix contains schematic diagrams of 14 TV receivers.

In reading through the text, the average technician will no doubt find information of technical value to him in his work. However, the probability is that the benefits derived from reading the book will not be worth the time spent. The 14 large schematics supplement the text nicely.—JK

METALLIC RECTIFIER MANUAL, prepared by Verlan Books, Inc. for Bradley Laboratories, Inc., New Haven, Conn. 128 pages, \$2.

Primarily prepared for the design and development engineer, this 128-page loose-leaf handbook on selenium and copper-oxide rectifiers deals with rectifier types, designs, circuitry, characteristics and applications. Included are details and circuits on such unusual applications as modulators, current limiters, arc suppressors, voltage regulators, dynamic brakes for motors and meter overload protectors.

To prevent its becoming outdated, the publisher will mail to all owners revisions and additions as they are warranted by developments in the field.

IT PAYS

to subscribe to

**RADIO -
ELECTRONICS**

Because . . .

YOU SAVE up to \$5.05 over the regular newsstand price.

YOU GET the best features on radio, TV, audio-high fidelity, and other phases of electronics by top writers every month.

YOU KEEP UP with all the new developments—transistors, printed circuits, microwaves, color TV, and the latest in audio.

YOU GLIMPSE into the future with articles which lift the electronic curtain on what lies ahead.

YOU'RE SURE of getting your copy every month, and you're protected against any possible price rises.

Don't miss these features in the months ahead!

- TV Sound Tuner for Your Car
- New Developments in Light Amplifiers
- Multiple Speakers for Higher Fidelity
- Electronics Searches for Oil
- Trouble Shooting the Video Detector
- Servicing Light Plane Radios

You save at these low rates!

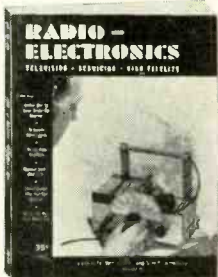

THREE YEARS—\$8.00

You save \$5.05 over the newsstand price

TWO YEARS—\$6.00

You save \$2.70 over the newsstand price

ONE YEAR—\$3.50

You save 85c over the newsstand price

START YOUR SUBSCRIPTION NOW

RADIO-ELECTRONICS, Dept. 45
25 West Broadway
New York 7, N.Y.

Please enter my subscription as indicated

- 3 Years—\$8.00 2 Years—\$6.00 1 Year—\$3.50
 Remittance enclosed I'll pay when billed.

NAME _____ Please print

STREET _____

CITY _____ ZONE _____ STATE _____

Rad-Tel for FULL YEAR Guaranteed Tubes

**70% to 90%
OFF!**

- Same Day Service
 - All Tubes Individually Boxed
 - 400 Types Always In Stock
- For Quality—Performance—Dependability

Famous Maker's 12" Speaker



Heavy Alnico 5 Magnet

\$3.95



Can Condenser Kit

10 to 100 mfd
150 to 450 V.
Asst. Kit of 10

\$1.65

Type	Price	Type	Price	Type	Price
OZ4M	.65	6AU5GT	.82	7C6	.59
1AX2	.62	6AU6	.46	7F7	.79
1B3GT	.73	6AV5GT	.83	7H7	.59
1E7	.29	6AV6	.40	7N7	.69
1H4	.30	6AX4GT	.65	7Q7	.66
1LA6	.69	6BA6	.49	7Y4	.69
1LH4	.69	6BC5	.54	12A4	.60
1LN5	.59	6BC7	.82	12AL5	.37
1R5	.62	6BE6	.51	12AT6	.41
1S5	.51	6BG6G	1.25	12AT7	.72
1U4	.57	6BH6	.53	12AU6	.46
1U5	.50	6BJ6	.49	12AU7	.60
1X2A	.68	6BK5	.80	12AV6	.39
3A3	.80	6BK7	.80	12AV7	.73
3AL5	.42	6BL7GT	.91	12AX4	.67
3AU6	.46	6BN6	.74	12AX7	.63
3BC5	.54	6BQ6GT	.98	12BA	.60
3BN6	.74	6BQ7	.90	12BA6	.49
3CB6	.54	6BZ7	.90	12BE6	.51
3Q4	.59	6C4	.40	12BF6	.39
3Q5GT	.69	6CB6	.54	12BH7	.63
3S4	.58	6CD6	1.11	12BY7	.65
3V4	.58	6CF6	.64	12CU6	.98
4BQ7	.90	6CS6	.51	12SA7GT	.65
4BZ7	.96	6H6GT	.41	12SJ7M	.67
5AW4	.59	6J5GT	.48	12SK7GT	.63
5J6	.64	6J6	.52	12SL7GT	.57
5T4	.79	6K6GT	.45	12SN7GT	.59
5U4G	.55	6L6	.84	12SQ7GT	.56
5U8	.78	6Q7	.45	12V6GT	.46
5V4	.71	6S4	.48	12X4	.38
5Y3GT	.37	6SA7GT	.55	14A7	.63
6AB4	.46	6SH7GT	.49	14B6	.63
6AC7M	.86	6SJ7GT	.50	14R7	.79
6AF4	.90	6SK7GT	.53	19BG6	1.39
6AG5	.56	6SL7GT	.67	19T8	.69
6AG7M	.99	6SN7GT	.59	25AV5GT	.83
6AH4	.67	6SQ7GT	.46	25BQ6GT	.98
6AH6	.73	6T4	.99	25L6GT	.51
6AK5	.75	6T8	.80	35B5	.52
6AK6	.59	6U8	.78	35C5	.51
6AL5	.42	6V6GT	.50	35L6GT	.51
6AM8	.78	6V8	.86	35W4	.47
6AN8	.78	6W4GT	.47	35Y4	.54
6AQ5	.50	6W6GT	.57	35Z3	.59
6AQ6	.46	6X4	.37	35Z5GT	.47
6AQ7	.70	6X5GT	.37	50A5	.55
6AR5	.45	6X8	.75	50B5	.52
6AS5	.50	7A7	.69	50C5	.51
6AS6	1.49	7A8	.68	50L6GT	.61
6AT6	.41	7B7	.49	80	.43
6AU4GT	.68	7C5	.69	117Z3	.45

Cathode Ray TUBE REJUVENATOR



For AC parallel circuits List Price \$5.95 . . . only

99¢

Assortment of Home, Auto and TV KNOB KIT



Reg. 12c to 18c ea. Bag of 50

\$1.49

Free Over 400 Tube Type List & Parts Catalog
TERMS: A 25% deposit must accompany all orders—balance C.O.D. All shipments F.O.B. Irvington warehouse. **ORDERS UNDER \$10—\$1.00 HANDLING CHARGE** . . . Subject to prior sale.
PLEASE: Send full remittance . . . allow for postage and save C.O.D. charges! We refund all unused money.

Rad-Tel TUBE CO.

115 COIT ST., IRVINGTON II, N. J.

"Integrity
Is Our Chief
Asset!"
Dept.
RE-4

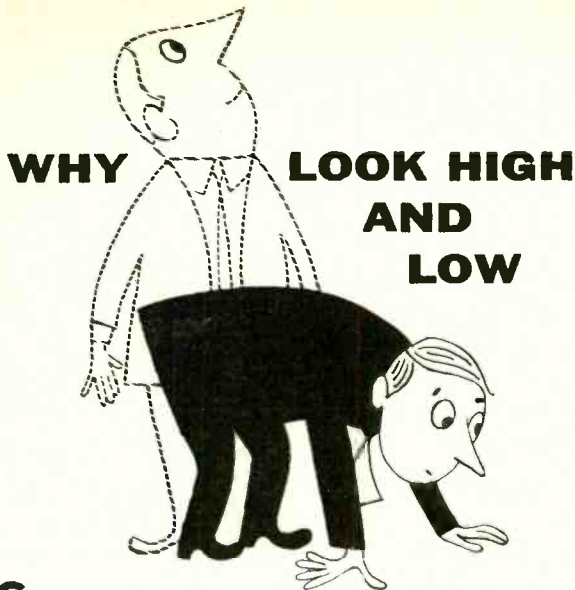

C-D IS THE ONLY COMPLETE LINE OF ELECTROLYTICS

No matter what you need in electrolytic capacitors—C-D has it. Every type, shape and rating . . . all of consistent high quality proven by outstanding field performance. C-D capacitors are always reliable . . . and readily available—because Distributors *who know*, carry the complete Cornell-Dubilier line.

Free! TV Capacitor "Replacement Guide"—and C-D Twist Prong Cross Index from your C-D Distributor. He's listed in your local Classified Telephone Directory.

C-D's "UP" Twist prong

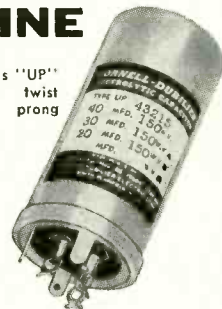

C-D's Blue Beaver

There are more C-D capacitors in use today than any other make.



CONSISTENTLY DEPENDABLE
CORNELL-DUBILIER CAPACITORS

PLANTS IN SOUTH PLAINFIELD, N. J.; NEW BEDFORD, WORCESTER AND CAMBRIDGE, MASS.; PROVIDENCE AND HOPE VALLEY, R. I.; INDIANAPOLIS, IND.; SANFORD AND FUGUAY SPRINGS, N. C.; SUBSIDIARY: THE RADIART CORPORATION, CLEVELAND, O.

Standard Western Electric Switchboard



CHEST MICROPHONE AND HEADSET

Brand New Complete and Guaranteed
Worth \$24.95 Only **\$4.95**

CONCORD RADIO 54 Vesey St., N. Y. 7.
Dept. CA MINIMUM ORDER \$5.00
20% deposit with C.O.D.
 Please send NEW 1955 CONCORD Catalog!

NAME _____
ADDRESS _____
CITY _____ ZONE _____ STATE _____

Standard Equipment for any TELEPHONE SWITCHBOARD. Complete with cable and dual telephone plug.
Western Electric Type 396A Chest-Phone.

Stock No. 88-A-0142093 each **\$4.95**

CONCORD RADIO • 54 VESEY ST. • NEW YORK 7, N. Y. • Digby 9-1132

BOOKS

(Continued)

RADIO-CONTROL HANDBOOK, by Howard G. McEntee. Gernsback Publications, Inc., 25 W. Broadway, New York 7, N. Y. 5½ x 8½ inches, 192 pages. \$2.25.

This handbook complements a previous book *Model Control by Radio* (Gernsback Library No. 43). The present work covers the more simple circuits, mostly one- and two-tubers. It also gives detailed, practical instruction for planning a control system, construction, operation and trouble shooting. It even describes the procedure for obtaining a Citizens band license. It will satisfy a beginner as well as an experienced hobbyist.

The first few chapters are concerned with mechanical details. Plan views give clear information on escapements, relays, rudder controls and actuators. These are followed by chapters on electronic circuits. Simple yet reliable receivers and transmitters are shown by diagram and photo. Readers will appreciate the clear pictorial views which show how to lay out small parts in limited space. The sets are for operation in either the 27-mc Citizens band or the 50-mc ham band. Pulse and tone control are covered.

The last few chapters discuss the installation and maintenance of the system. Direction finding, power measurement of r.f. output and relay adjustment are among the topics.—IQ

FUNDAMENTALS OF TRANSISTORS, by Leonard Krugman. John F. Rider Publisher, Inc., 480 Canal St., New York 13, N. Y. 5½ x 8½ inches, 140 pages. \$2.70.

Probably no other word in the entire history of electronics has suffered as much abuse as "fundamentals." To many, fundamentals means exactly that—a simple or basic approach. However, the amount of mathematics in this book would seem to take it out of the fundamental class, there just doesn't seem to be any other way of dealing with this subject.

Well written, with every evidence that the author has done a very creditable job, the book starts quite logically with semiconductor physics and continues through transistor operation, grounded base, emitter and collector circuitry, amplifiers and oscillators. An excellent advanced book for learning about transistors.—MC END

Latest Models - TV



"Now with this model you can follow your programs and do your washing at the same time."

RADIO SCHOOL DIRECTORY

MORE JOBS

than graduates

Demand for our engineering graduates exceeds supply. *Effective placement.* Study in this world-famed college established 1884. Quarters start June, September, January, March.

Bach. Sc. degree in 27 months
Complete Radio Eng. courses . . . TV, UHF and FM. Also Mech., Civil, Elec., Chem., Aero. and Adm. Eng.; Bus. Adm., Acct. Small classes. Well-equipped labs. Modest costs. Prep. courses. Write *Jean McCarthy, Director of Admissions, for Catalog and Campus View Book.*



TRI-STATE COLLEGE

2445 College Avenue, Angola, Indiana

GET INTO ELECTRONICS

You can enter this uncrowded, interesting field. Defense expansion, new developments demand trained specialists. Study all phases radio & electronics theory and practice: TV; FM; broadcasting; servicing; aviation, marine, police radio, 18-month course. Graduates in demand by major companies. H.S. or equivalent required. Begin Jan., March, June, Sept. Campus life. Write for catalog.

VALPARAISO TECHNICAL INSTITUTE
Dept. C Valparaiso, Ind.



TV REPAIRMEN EARN TOP MONEY!

IN JUST 12 MONTHS, COMPLETE TV SERVICE TRAINING, INCLUDING COLOR TV. Streamlined course gives you all essentials for a good job as service technician. Graduates in great demand; jobs are plentiful in this growing field. Other electronic courses in radio operation and maintenance. Day or evening classes. Opportunity for employment in local industry. Approved for Korean veterans.

Write for Catalog 111 Today

INDIANAPOLIS ELECTRONIC SCHOOL
312 E. Washington, Indianapolis 4, Ind.

RADIO ENGINEERING DEGREE IN 27 MONTHS

Intensive, specialized course including strong basis in mathematics and electrical engineering, advanced radio theory and design, television. Modern lab. Low tuition. Self-help opportunities. Also B.S. degree in 27 months in Aeronautical, Chemical, Civil, Electrical, and Mechanical Engineering. G.I. Gov't approved. Enter June, September, December, March. Catalog.

INDIANA TECHNICAL COLLEGE

1545 E. Washington Blvd., Fort Wayne 2, Indiana



RCA INSTITUTES, INC.

A service of Radio Corporation of America
350 West 4th St., New York 14, N. Y.

OFFERS COURSES IN ALL TECHNICAL PHASES OF RADIO, TELEVISION, ELECTRONICS

Approved for Veterans

Write Dept. RE-55 for Catalog

USE!

1955

HELP CRIPPLED CHILDREN
EASTER SEALS

THE NATIONAL SOCIETY FOR CRIPPLED CHILDREN AND ADULTS, INC.
11 S. LASALLE STREET, CHICAGO 3, ILL.

Electronic Engineers

Excellent opportunity for professional growth and advancement in interesting and important work.

Get Your F.C.C. LICENSE Quickly!

Correspondence or residence preparation for F.C.C. examinations. Results guaranteed.

An FCC commercial operator license means greater opportunities and higher pay. We are specialists in preparing you, in a MINIMUM OF TIME, to pass FCC examinations for all classes of licenses. Beginners get 2nd class license in 5 weeks and 1st class in 3 additional weeks. Write for our FREE booklet with complete details.

GRANTHAM School of Electronics

Dept. 101 - G, 6064 Hollywood Blvd., Hollywood 28, Calif.

TELEVISION

PREPARE FOR A GOOD JOB!

BROADCAST ENGINEER
ELECTRONICS
RADIO SERVICING

Television Servicing

(Approved for Veterans)

SEND FOR FREE LITERATURE

BALTIMORE TECHNICAL INSTITUTE
1425 EUTAW PLACE, BALTIMORE 17, MD.

CODE SENDING RECEIVING SPEED

Be a "key" man. Learn how to send and receive messages in code by telegraph and radio. Commerce needs thousands of men for jobs. Good pay, adventure, interesting work. Learn at home quickly through famous Candler System. Qualify for Amateur or Commercial License. Write for FREE BOOK.

CANDLER SYSTEM CO.
Dept. 3D, Box 928, Denver 1, Colo., U.S.A.

EARN MORE MONEY— BE A PROFESSIONAL TELEVISION SERVICE TECHNICIAN

GET DOWN-TO-EARTH PRACTICAL TV TRAINING WITH WTI EXPERTS FOR THE TOP PAYING \$5,000-\$10,000 PER YEAR JOBS.

UHF—COLOR—VHF

Master the latest, up-to-the-minute TV and Color TV developments QUICKLY.

SEND FOR FREE BOOK TODAY!

WESTERN TV offers real experience on live equipment in our BIG SHOPS AND LABORATORIES in the shortest practical time under expert instructors. Graduates are in big demand because they have the "field experience" necessary for immediate "bench" or supervisory positions. You learn every phase of Radio and TV servicing (AM, FM, VHF, UHF). WTI men win fast promotion . . . can demand better pay . . . develop highly profitable businesses of their own with the latest and most PRACTICAL PERSONALIZED TRAINING BEHIND THEM. You concentrate all your time on being a PROFESSIONAL TV SERVICE TECHNICIAN—non-essential math and engineering theory omitted. YOU CAN EARN WHILE YOU LEARN. Special Finance Plan.

APPROVED FOR VETERANS. Find out how you can get into the TOP PAY GROUP—Send for this fact-packed book NOW!

WESTERN TELEVISION INSTITUTE

America's Leading Television Servicing School

Western Television Institute Dept. E-4-55
341 W. 18th St., Los Angeles 15, Calif.
Without obligation, please send FREE fully illustrated booklet. (No salesman will call.)

NAME _____ AGE _____
ADDRESS _____
CITY _____ ZONE _____ STATE _____

Become an

ELECTRICAL ENGINEER



Major in Electronics or Power BS Degree in 36 months

Prepare now for a career as an electrical engineer or engineering technician — and take advantage of the many opportunities in these expanding fields.

You can save a year by optional year 'round study. Previous military, academic, or practical training may be evaluated for advanced credit.

Enter Radio and Television — courses 12 to 18 months

You can be a radio technician in 12 months. In an additional 6-months you can become a radio-television technician with Associate in Applied Science degree. Color television instruction is included in this program.

These technician courses may form the first third of the program leading to a degree in Electrical Engineering. Twenty-one subjects in electronics, electronic engineering and electronic design are included in these courses.

Courses also offered: radio-television service (12 mos.); electrical service (6 mos.); general preparatory (3 mos.).

Terms — July, September, January, April

Faculty of specialists. 50,000 former students—annual enrolment from 48 states, 23 foreign countries. Non-profit institution. 52nd year. Courses approved for veterans. Residence courses only.

MS-6A

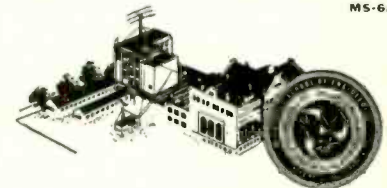

MILWAUKEE SCHOOL OF ENGINEERING

MILWAUKEE SCHOOL OF ENGINEERING
Dept. RE-455, 1025 N. Milwaukee Street
Milwaukee 1, Wisconsin

Send FREE illustrated booklets
 Career in Electrical Engineering,
 Career in Radio-Television.

I am interested in _____ (name of course)

Name _____ Age _____

Address _____

City _____ Zone _____ State _____

If veteran, indicate date of discharge _____

TRIO

America's Top Quality Line...

is the Best Buy for the Money!

Behind every TRIO antenna is the RESEARCH ENGINEERING—EXPERIENCE and CRAFTSMANSHIP that has made TRIO the leader in antenna development.



Patented "INSTA-LOK" CLAMP

(Good-Bye Nuts)
Revolutionary TRIO clamp employed on all TRIO antennas with parasitic elements. Permits instant flip-out assembly — permanent alignment and ultra-strength. Nothing stronger! Nothing faster!

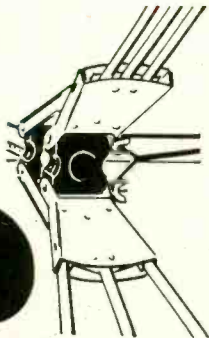

New "Vari-Con" Head

Four hi-strength aluminum adjusting arms. Interlocking butterfly sections. Heavier snap-action spring assembly. Spring dampeners lessen vibration and breakage. Mycastyrene insulators. Used on the popular TRIO "88" and "Vari-Con" antennas.

COMPARE THESE FEATURES!

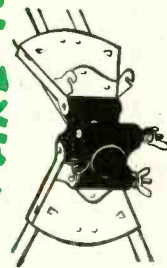

New Mini-Up Conical Head

Superior strength — with the new modern riveted construction. No shedding elements as with doweled, friction held elements.



Heaviest Booms!

Thick-wall, extra sturdy 1 1/4" diameter booms used on ALL low band Yagis. Highest grade Alcoa aluminum for added strength.

THE TRIO "ARISTOCRAT"

America's Most Dependable Rotator Is Also America's Most Beautiful

Control unit available in four glorious colors.

TRIO — THE COMPLETE LINE
YAGIS CONICALS "VARI-CONS"
RADAR SCREEN TYPES COLINEAR ARRAYS
UHF & REFLECTOR TYPES CONICAL — YAGIS

America's No. 1 Choice

The TRIO "88"

More DB gain per dollar cost. Completely pre-assembled, ready to unfold and install. New Mycastyrene insulators for greater strength and insulating qualities. Highest quality Alcoa aluminum elements and extra sturdy boom. Exclusive, sensational TRIO Jr. & Sr. "Insta-Lok" clamps combined with famous "Vari-Con" head gives the "88" all the plus features everyone wants. Rugged construction, completely pre-assembled, superior performance and low unit cost. The best buy on the market today! Available in single or two bay models.



NEWEST ADDITIONS TO THE TRIO LINE

The TRIO "99"

CHANNELS 2-13

A well-known broad band Yagi type featuring sturdier construction, higher quality materials and faster assembly. Improved forward gain with reduced side and rear pick-up as a result of TRIO engineering and research. Uses famous "Insta-Lok" clamps and all riveted construction as originally introduced by TRIO.



The TRIO "177"

CHANNELS 2-13

High gain, broad band type now greatly improved as a result of TRIO engineering. Highest quality Alcoa elements and boom. Exclusive "Insta-Lok" clamps for easy, fast assembly. Designed for low wind resistance and bestment for rotator operation.



TRIO MANUFACTURING COMPANY · GRIGGSVILLE, ILLINOIS

Copyright 1955 by

TRIO MANUFACTURING CO.

Leader in Antenna Development

STANDARD BRAND TUBES

Only the 5 Top-Quality Brands Shipped

- Individually boxed. • Only 1st quality.
- Latest Dating • Standard RTMA Guarantee
- No private label, electrical or mechanical rejects.
- No rebrands or reworked "bargains."

Write for Free 1955 New Air-Mail Handy-Order Blank.

- Lists ALL Popular TV & Radio Types.
- Makes Mail-Order a Pleasure.
- All Tube Orders Over \$25.00 (with Remittance) Postpaid, Overnight Shipment.

SPECIAL-PURPOSE TUBES

Write for our complete listing on XMTG, Industrial, Special-Purpose and Crystal Diodes. We stock over 2,000 types at excellent prices.

CBS **HYTRON**

- Immediate shipments on all types of CBS Cathode-Ray Tubes direct from factory-to-you! Only 1st quality new pix tubes shipped. Write for complete price list. New low prices.

METEOROLOGICAL TRANSMITTER

Type T-49C. Uses RCA 3A5. Complete with tube, antenna, battery harness. Brand New Sizes 4 1/2" x 2 1/2" x 2 1/4" Only **\$1.75**

3,000 VOLT POCKET MULTITESTER

AC: 0-15, 150, 750, 3000 volts.
DC: 0-15, 75, 300, 750, 3000 volts.
DC MA: 0-15, 150, 750 ma.
Resistance: 0-10,000, 100,000 ohms.
Complete with battery, test leads. Only 3 1/2" W x 4 1/4" H x 1 3/4" deep. Brand New @ Only \$9.95.

TWO-COLORED TUBE CARTONS, with new Safety Partitions. Prevents Tube Breakage. This Stayer-Gloss Red and Black Carton is the Most Distinctive Box Available Today! Minimum 100 any one size. Discounts on full case lots. Also available in glossy white, unprinted. Boxes F.O.B., N.Y.

SIZE	EACH
Miniature..... (6AU6, 6AL5, etc.)	\$.01
GT..... (6SN7, 6W4, etc.)	\$.0125
LARGE GT..... (1B3, 6BQ6GT, etc.)	\$.015
LARGE G..... (5U4G, 6BQ6G, etc.)	\$.02

Terms: 25% with order, balance C.O.D. All merchandise guaranteed. F.O.B., N.Y.C.
New phone and address. Phone: Walker 5-7000.

BARRY ELECTRONICS CORP.
512 Broadway N.Y. 12, N.Y.



DON'T THROW OLD RADIOS AWAY!

Here's the data you need to fix them FAST and r-i-g-h-t!

Just look up the how-to-do-it data on that old radio you want to fix!

Four times out of 5, this giant, 3 1/2-pound, 744-page Ghivardi RADIO TROUBLESHOOTER'S HANDBOOK gives exactly the information you need to fix it in a jiffy. Tells what is likely to be causing the trouble - shows how to fix it. No useless testing. No wasted time. Handbook covers practically every radio receiver model made by 202 manufacturers between 1925 and 1942. Using it, even beginners can easily fix old sets which might otherwise be thrown away because service information is lacking. With a few simple repairs, most of these old sets can be made to operate perfectly for years to come.

THE ONLY GUIDE OF ITS KIND!

Cuts service time in half!

Included are common trouble symptoms and their remedies for over 4,800 models of old home, auto radios and record changers. Airline, Apex, Arvin, Atwater Kent, Belmont, Bosch, Brunswick, Clarion, Crosley, Emerson, Fada, G-E, Koister, Majestic, Motorola, Philco, Pilot, RCA, Silvertone, Sparton, Stromberg and dozens more. Gives how-to-do-it data on SPECIFIC jobs—NOT general theory. Includes hundreds of pages of invaluable tube and component data, service short cuts, etc.

...TRY IT 10 DAYS... at our risk!

Dept. RE-45, RINEHART & CO., Inc.
232 Madison Ave., New York 16, N.Y.
Send Ghivardi's RADIO TROUBLESHOOTER'S HANDBOOK for 10-day free examination. If I decide to keep book, I will then remit the full price of only \$6.50 plus a few cents postage. Otherwise, I will return book postpaid and owe you nothing.

NAME.....
ADDRESS.....
CITY, ZONE, STATE.....
Outside U.S.A.—Price \$7.00, cash only. Same return privilege

ADVERTISING INDEX

Radio-Electronics does not assume responsibility for any errors appearing in the index below.

Acro Products Co.	82
Aermotor Co.	118
All Channel Antenna Corp.	137
Allied Radio Co.	11, 134
American Microphone Co.	119
American Phenolic Corp.	106
Amplifier Corporation of America	139
Arkey Radio Kits, Inc.	140
Atlas Sound Corp.	142
Audel Publishers	117
B & K Mfg. Co.	110
Barry Electronics Corp.	145
Baumker Mfg. Co.	138
Bell Telephone Labs.	24
Brooks Radio & TV Corp.	109
CBS Hytron (Div. of Columbia Broadcasting System)	14, 15
Capitol Radio Engineering Institute	17
Channel Master Corp.	18, 19
Chicago Standard Transformer Corp.	119
Circle Electronics Products Company	130
Cleveland Institute of Radio-Electronics	9
Collins Radio Products Co.	128
Concord Radio	142
Cornell Dubilier Electric Corp.	129, 133, 142
Coyne Electrical School	129, 132, 139
DeVry Technical Institute	7
EBV Sales Co.	134
Edlie Electronics	111
Electric-Voice, Inc.	136
Electronic Instrument Co. (EICO)	27, 28
Electronic Measurements Corp.	103
Electronic Organ Arts	120
E-Z Way Towers, Inc.	82
General Cement Mfg. Co.	99
General Industries Co.	12
General Test Equipment	110
Geneva Electronics	119
Gramer Halldorson Transformer Corp.	145
Hawkins, P. E., Co.	133
Heath Co.	65-76
Hershel Radio Co.	115
Hickok Electrical Instrument Co.	Inside Front Cover
Hueker Electronics	116
Hudson Specialties Co.	136
Hughes Research & Development Labs.	94, 124
Hycor Mfg. Co.	125
Indiana Technical College	130
Instructograph Co.	120
Instruments For Service, Inc.	140
Jensen Industries	132
Jones & Laughlin Steel Corp.	131
Kay-Townes Antenna Corp.	89
Lafayette Radio Corp.	91
Leotone Radio Corp.	138
Leslie Creations	133
Macmillan Co., The	134
Mallory, P. R. & Co., Inc.	87
McGraw-Hill Book Co.	108
Moss Electronic Distributing Co.	112, 113
National Radio Institute	3, 13, 122
National Schools	5
Ohmite Mfg. Co.	107
Opportunity Adlets	117
Oxford Electric Co.	130
Permoflux Corp.	16
Phaetron Co.	20
Philco Corporation	22, 23
Precision Apparatus Co., Inc.	12, 121
Progressive "Edu-Kits", Inc.	102
RCA Institutes, Inc.	21, 83
RCA Tube Div. (Radio Corporation of America)	Back Cover
Radiel Tube Co.	141
Radiart Corp.	26
Radio City Products Co., Inc.	105
Radio Craftmen, Inc., The	92, 93
Baltimore Technical Institute	88
Candler System Co.	108
Grantham School of Electronics	114
Indiana Technical College	136
Indianapolis Electronic School	135
Milwaukee School of Engineering	135
RCA Institutes, Inc.	21, 83
Tri-State College	135
Valparaiso Technical Institute	135
Western Television Institute	135
Radio Television Training Association	25
Raytheon Mfg. Co.	8
Record Changer—Wire & Tape Parts Co.	110
Rider, John F., Inc.	86, 139
Rinehart & Co., Inc.	116, 120, 138, 145
Rockbar Corp.	108
S & A Electronics	117
Sams, Howard W. & Co., Inc.	88
Sansgou Electric Co.	126, 127
Seco Mfg. Co.	118
Service Instruments Co.	136
Sherwood Electronic Laboratories	114
Skysweeper, Inc.	134
Sonotone Corp.	77
Stan-Bur Radio & Electronics	136
Stanley Electronics Corp.	132
Steve-EI Electronics Corp.	140
Sylvania Electric Products, Inc.	97
Tab	146
Technical Appliance Corp.	85
Tele-Diagnosis Co.	108
Terado Co.	111
Transamerica Electronics	117
Transvision, Inc.	123, 140
Trico Mfg. Co.	144
Triplet Electrical Instrument Co.	Inside Back Cover
Tung-Sol Electric Co.	10
Vidaire Electronics Mfg. Corp.	140
Ward Products Corp.	81
Webster Electric Corp.	135
Went Products, Inc.	100
Wholesale Radio Parts Co.	120
Winston Electronics, Inc.	95
Zingo Products	110

NEW! IT'S YOURS!

TV INDEXED 3 WAYS

Halldorson

REPLACEMENT PARTS GUIDE

1954 EDITION

GRAMER-HALLDORSON

IT'S FREE!

The Only T-V Parts Guide
CROSS-INDEXED
THREE WAYS:
PARTS 1. by Model Number
EASY TO FIND 2. by Chassis Number
3. by Part Number

This New Guide makes available the very **NEWEST T-V REPLACEMENT PARTS** in addition to the complete Gramer-Halldorson line. It is obtainable at your dealer without cost. If he cannot supply you write direct c/o Dept. R. E.

A Splendid Example of the Many New Items Available:



TRANSFORMERS
Power - Audio - Filament - Output
Input - Flyback - All Types!

The NEW GRAMER HALLDORSON DEFLECTION YOKE

Write FOR FULL DETAILS

Address: Dept. R. E.
GRAMER Halldorson
TRANSFORMER CORPORATION
2734 N. PULASKI ROAD, CHICAGO 39, ILLINOIS

HI-FI AMPLIFIER KIT



Model TAB/20 Ultra-linear Williamson Type Amplifier. 20 watt. Freq. 12-36 kc/10 watt. 8-80 kc/5 watt (-). 1 Di. Dist. 0-25% 2000 cps. 8-16 ohm. INPUT: Hi-imp. Finest quality components. Full detailed instructions. Ship. wt. 2.5 lbs. "TAB" Special...\$49.95. Wired ready to go...\$1.00

"TAB" THAT'S A BUY



MIKE & HEADSETS
Sound Pwr Headset, Chest Mike & Throat Mike U.S.N. \$15.98
T300 Throat Mike Dble Button 200-500 cps 22B1630V. 6/54
Crystal Mike & Cable... 3 for \$5
230 Hz Headset High Imped. 24K Ohm \$4.98
Navy Mike, Carbon... \$1.98; 3 for \$5

230 TO 115V AUTOFORMERS
For 220-240V/50-60 cy Input to 110-120V or Up-Down With Cor. Plug & Receptacle.
TPA050/50W \$2.55; TPA075/75W \$3.65
TPA100/100W \$4.00; TPA200/200W 5.75
TPA250/250W \$6.75; TPA300/300W 7.25
TPA500/500W \$8.25; TPA750/750W 11.75
Model TPA1000/1000Watts/1KW. \$16.95
Model TPA1500/1500Watts/1.5KW. \$22.50
Model TPA2000/2000Watts/2KW. \$28.95
Model TPA3000/3000Watts/3KW. \$49.95
\$100 Order Take 10% Disc.

POWER SUPPLY KIT
Kit Consists of: Fully Shielded TRANSFORMER PR. 0.15V/60
2V/20AH Willard 2V/20AH
SELENIUM RECTIFIER
FILTER CONDS. 50MFD/300
VDC. All for Only... \$2.25
GET YOUR NOW!
Order in Lots of 3; \$1.98

NEW VARIABLE & 12 VOLT/12A DC POWER SUPPLY
Completely Built (Not a Kit)
TE12V12AC \$29.95
BATTERY ELIMINATOR, CHARGER, MODEL ER, PLATER, AIRCRAFT, MARINE & Any DC Req. Contains P.W. Xtra size Selenium Rectifier 5" x 6" plates. HV Transformer, Volt & Amp Meters, Switches, Circuit Breaker, Fuse, Capacitor, Vari Pwr Control, Cord & Plug. Designing continuous service & up to 20 amps intermittent overhead. Housed in heavy duty Black crackle finish steel cabinet.

STORAGE BATTERIES
2V/20AH Willard plus 2V V-I Inverter \$29.95
2V/20AH w/Vid & Acid* \$2.98
6V/6AH Batt. w/Acid* \$2.98
6V/6AH Willard NT6/B32/4Exp. \$3.25
*Acid Shipped in Bottles R-Exp. Only.

4MFD/1200VDC OR 10MFD/600VDC (ASST'D) Lots of 12 \$1.50; Singly \$1.79

VARIABLE VOLTAGE XFMR'S Superior-GR-STACO-UTC

- 0-132V 1.25A \$ 7.99
- 0-135V 3A 11.25
- Cased 0-135V 7.5A 20.70
- Uncased 0-135V 7.5A 16.20
- Cased 0-270V 3A 23.40
- Uncased 0-270V 3A 18.00
- Cased 0-135V 15A 41.98
- Cased 0-270V 9A 41.98

Six or more 10% discount

- METER BARGAINS**
- 0-1 MADC/3 1/2 Rnd \$3.95
 - 0-1 MADC/3 1/2 Rnd \$7.00
 - 0-5 MADC/3 1/2 Rnd \$3.70
 - 0-100 MADC 3 1/2 Rnd \$3.50
 - 0-100 MADC 3 1/2 Sq \$4.95
 - 800 VDC/3 1/2 Sq \$8.95
 - 5 MADC Tuning Meter AN \$1.39; 3/4
 - Weston 120 MA/RF/3 Rnd \$10.95
 - Weston VU-20 to 30/30 \$31.00

MONTHLY BARGAINS

- C.D. Condenser BT14.012/25,000 WDC \$4.98; 3/512
- Performer Output Xing \$2.00
- IF Trans. 456 KC. 49c; 6/52
- H330 Cord CB620R 49c; 12/55
- Planetary Dr. 514; 1 to \$2.49
- Brush MCD Neon 4 Amps \$2.00
- Isol. Transformer VS 110 to 220 or 440/150 watt \$4; 2 for \$7
- Globar T2FD (3500/500W RP) \$1.00
- Resistor & Clips... \$2.00

NEW OIL CONDENSERS

- FRESH STOCK**
- 1.3MFD/2400WVDC \$1; 4/53
 - 1.5MFD/3000WVDC \$2; 3/52
 - 25MFD/100WVDC \$8; 6/536
 - 26MFD/1000WVDC \$8; 6/538
 - 48MFD/1000WVDC \$11; 1/538
 - 0.25MFD/1200WVDC \$20; 2/53
 - 0.38MFD/2400WVDC 29c; 25/53

866A KIT [12] 866A Tubes, Sockets & Transformers—\$4.98

RHEOSTAT BUY

- 15 Ohm 25W...\$1.10; 10/57
 - 50 Ohm 25W...\$1.10; 10/57
 - 75 Ohm 25W...\$1.98; 10/54
 - 150 Ohm 25W...\$1.10; 10/57
 - 250 Ohm 25W...\$1.10; 10/56
 - 500 Ohm 25W...\$1.10; 10/57
 - 1200 Ohm 25W...\$1.98; 2/59
 - 5000 Ohm 25W...\$1.25; 10/59
- Write for Quantity Prices

IT'S "TAB" FOR TOOLS

- Famous Soldering Guns
- TA-5.4 Gun 135W...\$7.89
- TA-10 Gun 180W...\$5.83
- TA-D-4 100-150W...\$6.25
- TA-D-5 200-300W...\$10.53
- LENK Gun—The Best...\$7.45

Speedway Electric Drills

- 200J 1/4" Electric drill w/Chuck...\$14.25
- 400J 1/2" Electric drill w/Chuck...\$29.95

New Swiss "QUICKIE" Wrench

10 Way wrench w/1001 uses. Fits US & all sizes Sq. & Hex Head nuts & bolts 1/4" to 9/16" RUSTPROOF. GTD: Brkproof (Resip) U.S.A. \$6.55

Swedish Hand Saw

FINEST SWEDISH STEEL Genuine Sandvik Grade 24 to 30" long "TAB" Special \$3.95 Cross Cut \$10.98 Reg.

COMPONENT KITS

- Resistors 100 Ass't'd .95 ea. 6/85 ea
- Tube Sockets 20 Ass't'd .85 ea. 6/75 ea
- Ceramic Cond. 25 Ass't'd .6/75 ea
- Vac. WW. Res. 15 Ass't'd .6/51 ea
- Rotary 10 Ass't'd .95 ea. 6/85 ea
- Knobs 10 Ass't'd .98 ea. 6/89 ea

CIRCUIT BREAKERS

- Heinmann Magn. Bkrs. Amps; 220, 240, 277, 300, 345, 375, 400, 450, 500, 575, 600, 675, 750, 825, 900, 1000, 1100, 1250, 1500, 1750, 2000, 2250, 2500, 2750, 3000, 3500, 4000, 4500, 5000, 5500, 6000, 6500, 7000, 7500, 8000, 8500, 9000, 9500, 10000, 11000, 12000, 13000, 14000, 15000, 16000, 17000, 18000, 19000, 20000, 22000, 24000, 26000, 28000, 30000, 32000, 34000, 36000, 38000, 40000, 42000, 44000, 46000, 48000, 50000, 55000, 60000, 65000, 70000, 75000, 80000, 85000, 90000, 95000, 100000, 110000, 120000, 130000, 140000, 150000, 160000, 170000, 180000, 190000, 200000, 220000, 240000, 260000, 280000, 300000, 320000, 340000, 360000, 380000, 400000, 420000, 440000, 460000, 480000, 500000, 550000, 600000, 650000, 700000, 750000, 800000, 850000, 900000, 950000, 1000000, 1100000, 1200000, 1300000, 1400000, 1500000, 1600000, 1700000, 1800000, 1900000, 2000000, 2200000, 2400000, 2600000, 2800000, 3000000, 3200000, 3400000, 3600000, 3800000, 4000000, 4200000, 4400000, 4600000, 4800000, 5000000, 5500000, 6000000, 6500000, 7000000, 7500000, 8000000, 8500000, 9000000, 9500000, 10000000, 11000000, 12000000, 13000000, 14000000, 15000000, 16000000, 17000000, 18000000, 19000000, 20000000, 22000000, 24000000, 26000000, 28000000, 30000000, 32000000, 34000000, 36000000, 38000000, 40000000, 42000000, 44000000, 46000000, 48000000, 50000000, 55000000, 60000000, 65000000, 70000000, 75000000, 80000000, 85000000, 90000000, 95000000, 100000000, 110000000, 120000000, 130000000, 140000000, 150000000, 160000000, 170000000, 180000000, 190000000, 200000000, 220000000, 240000000, 260000000, 280000000, 300000000, 320000000, 340000000, 360000000, 380000000, 400000000, 420000000, 440000000, 460000000, 480000000, 500000000, 550000000, 600000000, 650000000, 700000000, 750000000, 800000000, 850000000, 900000000, 950000000, 1000000000, 1100000000, 1200000000, 1300000000, 1400000000, 1500000000, 1600000000, 1700000000, 1800000000, 1900000000, 2000000000, 2200000000, 2400000000, 2600000000, 2800000000, 3000000000, 3200000000, 3400000000, 3600000000, 3800000000, 4000000000, 4200000000, 4400000000, 4600000000, 4800000000, 5000000000, 5500000000, 6000000000, 6500000000, 7000000000, 7500000000, 8000000000, 8500000000, 9000000000, 9500000000, 10000000000, 11000000000, 12000000000, 13000000000, 14000000000, 15000000000, 16000000000, 17000000000, 18000000000, 19000000000, 20000000000, 22000000000, 24000000000, 26000000000, 28000000000, 30000000000, 32000000000, 34000000000, 36000000000, 38000000000, 40000000000, 42000000000, 44000000000, 46000000000, 48000000000, 50000000000, 55000000000, 60000000000, 65000000000, 70000000000, 75000000000, 80000000000, 85000000000, 90000000000, 95000000000, 100000000000, 110000000000, 120000000000, 130000000000, 140000000000, 150000000000, 160000000000, 170000000000, 180000000000, 190000000000, 200000000000, 220000000000, 240000000000, 260000000000, 280000000000, 300000000000, 320000000000, 340000000000, 360000000000, 380000000000, 400000000000, 420000000000, 440000000000, 460000000000, 480000000000, 500000000000, 550000000000, 600000000000, 650000000000, 700000000000, 750000000000, 800000000000, 850000000000, 900000000000, 950000000000, 1000000000000, 1100000000000, 1200000000000, 1300000000000, 1400000000000, 1500000000000, 1600000000000, 1700000000000, 1800000000000, 1900000000000, 2000000000000, 2200000000000, 2400000000000, 2600000000000, 2800000000000, 3000000000000, 3200000000000, 3400000000000, 3600000000000, 3800000000000, 4000000000000, 4200000000000, 4400000000000, 4600000000000, 4800000000000, 5000000000000, 5500000000000, 6000000000000, 6500000000000, 7000000000000, 7500000000000, 8000000000000, 8500000000000, 9000000000000, 9500000000000, 10000000000000, 11000000000000, 12000000000000, 13000000000000, 14000000000000, 15000000000000, 16000000000000, 17000000000000, 18000000000000, 19000000000000, 20000000000000, 22000000000000, 24000000000000, 26000000000000, 28000000000000, 30000000000000, 32000000000000, 34000000000000, 36000000000000, 38000000000000, 40000000000000, 42000000000000, 44000000000000, 46000000000000, 48000000000000, 50000000000000, 55000000000000, 60000000000000, 65000000000000, 70000000000000, 75000000000000, 80000000000000, 85000000000000, 90000000000000, 95000000000000, 100000000000000, 110000000000000, 120000000000000, 130000000000000, 140000000000000, 150000000000000, 160000000000000, 170000000000000, 180000000000000, 190000000000000, 200000000000000, 220000000000000, 240000000000000, 260000000000000, 280000000000000, 300000000000000, 320000000000000, 340000000000000, 360000000000000, 380000000000000, 400000000000000, 420000000000000, 440000000000000, 460000000000000, 480000000000000, 500000000000000, 550000000000000, 600000000000000, 650000000000000, 700000000000000, 750000000000000, 800000000000000, 850000000000000, 900000000000000, 950000000000000, 1000000000000000, 1100000000000000, 1200000000000000, 1300000000000000, 1400000000000000, 1500000000000000, 1600000000000000, 1700000000000000, 1800000000000000, 1900000000000000, 2000000000000000, 2200000000000000, 2400000000000000, 2600000000000000, 2800000000000000, 3000000000000000, 3200000000000000, 3400000000000000, 3600000000000000, 3800000000000000, 4000000000000000, 4200000000000000, 4400000000000000, 4600000000000000, 4800000000000000, 5000000000000000, 5500000000000000, 6000000000000000, 6500000000000000, 7000000000000000, 7500000000000000, 8000000000000000, 8500000000000000, 9000000000000000, 9500000000000000, 10000000000000000, 11000000000000000, 12000000000000000, 13000000000000000, 14000000000000000, 15000000000000000, 16000000000000000, 17000000000000000, 18000000000000000, 19000000000000000, 20000000000000000, 22000000000000000, 24000000000000000, 26000000000000000, 28000000000000000, 30000000000000000, 32000000000000000, 34000000000000000, 36000000000000000, 38000000000000000, 40000000000000000, 42000000000000000, 44000000000000000, 46000000000000000, 48000000000000000, 50000000000000000, 55000000000000000, 60000000000000000, 65000000000000000, 70000000000000000, 75000000000000000, 80000000000000000, 85000000000000000, 90000000000000000, 95000000000000000, 100000000000000000, 110000000000000000, 120000000000000000, 130000000000000000, 140000000000000000, 150000000000000000, 160000000000000000, 170000000000000000, 180000000000000000, 190000000000000000, 200000000000000000, 220000000000000000, 240000000000000000, 260000000000000000, 280000000000000000, 300000000000000000, 320000000000000000, 340000000000000000, 360000000000000000, 380000000000000000, 400000000000000000, 420000000000000000, 440000000000000000, 460000000000000000, 480000000000000000, 500000000000000000, 550000000000000000, 600000000000000000, 650000000000000000, 700000000000000000, 750000000000000000, 800000000000000000, 850000000000000000, 900000000000000000, 950000000000000000, 1000000000000000000, 1100000000000000000, 1200000000000000000, 1300000000000000000, 1400000000000000000, 1500000000000000000, 1600000000000000000, 1700000000000000000, 1800000000000000000, 1900000000000000000, 2000000000000000000, 2200000000000000000, 2400000000000000000, 2600000000000000000, 2800000000000000000, 3000000000000000000, 3200000000000000000, 3400000000000000000, 3600000000000000000, 3800000000000000000, 4000000000000000000, 4200000000000000000, 4400000000000000000, 4600000000000000000, 4800000000000000000, 5000000000000000000, 5500000000000000000, 6000000000000000000, 6500000000000000000, 7000000000000000000, 7500000000000000000, 8000000000000000000, 8500000000000000000, 9000000000000000000, 9500000000000000000, 10000000000000000000, 11000000000000000000, 12000000000000000000, 13000000000000000000, 14000000000000000000, 15000000000000000000, 16000000000000000000, 17000000000000000000, 18000000000000000000, 19000000000000000000, 20000000000000000000, 22000000000000000000, 24000000000000000000, 26000000000000000000, 28000000000000000000, 30000000000000000000, 32000000000000000000, 34000000000000000000, 36000000000000000000, 38000000000000000000, 40000000000000000000, 42000000000000000000, 44000000000000000000, 46000000000000000000, 48000000000000000000, 50000000000000000000, 55000000000000000000, 60000000000000000000, 65000000000000000000, 70000000000000000000, 75000000000000000000, 80000000000000000000, 85000000000000000000, 90000000000000000000, 95000000000000000000, 100000000000000000000, 110000000000000000000,



SIDNEY C. SILVER, Managing Editor,
TECHNICIAN, CALDWELL-CLEMENTS, INC.
says, "No service man will quarrel with the statement
that properly designed, accurate test equipment is
A must in the TV-Radio
Repair Shop."

"An instrument of good quality can, when properly used, greatly speed up service work and boost service revenue. A unit with significant design faults, on the other hand, particularly faults (or limitations) poorly comprehended by the user can make a difficult service job out of a relatively simple one, and cause appreciable losses of time and money."

Reprints of Mr. Silver's complete article on test equipment are available at no cost from your parts jobber or Triplet Electrical Instrument Company, Bluffton, Ohio.



MODEL 3413A

TRIPLET

TRIPLET ELECTRICAL INSTRUMENT CO., Bluffton, Ohio

**Don't let your profit suffer
from obsolete equipment!**

If you test 3 tubes a day
Triplet Model 3413A will

Pay for itself in one year
at the customary checking charge of 10 cents a tube
you will write off the cost of only \$79.50 in actually
less than a year. And you will have

**Faster,
more accurate testing—Featuring:**

IMPROVED LEVER SWITCHING for complete control of each tube element. Gets at each tube pin to make an open and short check, exclusive with Triplet in this price range.

GREATER METER SENSITIVITY for the new type tubes with low cathode current.

TV PICTURE TUBE TESTS by means of the new BV adapter, without removing the tube from the receiver.

ILLUMINATED SPEED-ROLL CHART with test settings for over 700 tubes at the flick of a finger.

SPECIAL CIRCUIT FEATURE accurately compensates to provide correct voltage on each tube test.

SHORT TEST for each element by a simple flip of the switch.

BIG 6-INCH METER, direct reading "BAD-?-GOOD" dial.

TESTS NEW series filament tubes.

FULTON T V 3-57
 % PAUL S BOLLARO
 434 FULTON ST
 ELIZABETH 1 N J

able output from TV power supplies



**... USE RCA TUBES
 with built-in quality!**

To meet the ever-increasing demand for higher currents in the low-voltage supplies of modern TV receivers, RCA is making available the new, outstanding 5U4-GB. This tube is a heavy-duty version of the top-quality RCA 5U4-G which is highly recommended for applications where the increased ratings of the 5U4-GB are not required. The 5U4-GB features more plate area for better heat conduction, increased plate thickness for more uniform heat dissipation—and new button stem construction to reduce leakage and electrolysis. Result—a reserve operating capability which assures you top performance in high-current TV power supplies.

*Here's another example of how
 RCA safeguards your servicing
 profits by "building-in" extra
 quality where you need it!*



RADIO CORPORATION of AMERICA
 ELECTRON TUBES
 HARRISON, N.J.

Your First Choice for TV circuits . . . dependable RCA Tubes.

ADV Plans, LLC

Copyright Notice:

The entire contents of this CD/DVD are copyright 2014 by ADV Plans, LLC. All Rights Reserved.

Reproduction or distribution of this disk, either free or for a fee is strictly prohibited. We actively monitor and remove listings on eBay thru Vero.

You are free to copy or use individual images in your own projects, magazines, brochures or other school projects.

Only the sellers listed here are authorized distributors of this collection:
www.theclassicarchives.com/authorizedsuppliers

Please view our other products at
www.theclassicarchives.com,
or our ebay stores:

[TheClassicArchives](#)
[ADVPlans](#)
[SuperShedPlans](#)

